

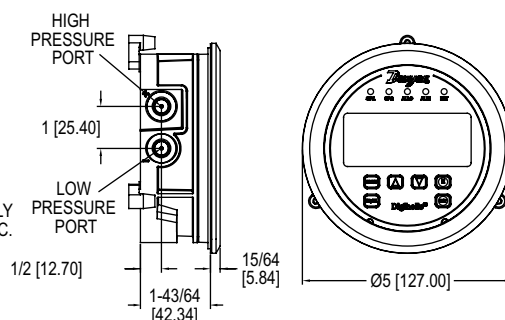

Series DHC Digihelic® Differential Pressure Controller

Specifications - Installation and Operating Instructions

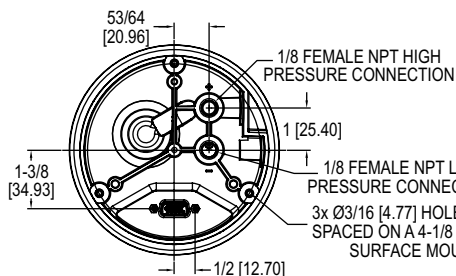

The **Series DHC Digihelic® Differential Pressure Controller** is a 3-in-1 instrument possessing a digital display gage, control relay switches, and a transmitter with both current and voltage outputs. Combining these 3 features allows the reduction of several instruments with one product, saving inventory, installation time, and cost. The Series DHC Digihelic® differential pressure controller is the ideal instrument for pressure, velocity, and volumetric flow applications reading in several commonly used engineering units with optional unidirectional or bidirectional ranges. These units achieve a 1.5% or better accuracy on extremely low ranges, and 0.5% accuracy for ranges at or above 1 in w.c. Calibration can be performed in the field, making maintaining its accuracy more manageable. Additionally, the Series DHC Digihelic® differential pressure controller includes 2 SPDT control relays with adjustable deadbands. Programming the unit is simple using the built-in menu. With scalable 4-20 mA, selectable voltage process outputs, and selectable Modbus® or BACnet communication, this controller can easily fit into your application.

INSTALLATION

Select a clean, dry location that is free from shock and vibration where temperature limits will not be exceeded. Distance from the transmitter to the receiver is limited only by total loop resistance. See WIRING section. The tubing feeding pressure to the instrument can be practically any length required, but longer lengths will slightly increase response time.

All standard models are calibrated for use in a vertical mounting position. The DHC will perform properly when mounted at any angle but should be zeroed before use.

Pressure Connections

For installation convenience, there are two sets of 1/8" female NPT pressure ports; one set is located on the back of the unit and the other is located on the side. Be sure to seal the unused ports with the included pipe plugs (accessory A-330).

- **Positive Pressure:** Connect tubing to the HIGH PRESSURE port (indicated with a "+" sign) and vent the LOW PRESSURE port (indicated with a "-" sign) to atmosphere.
- **Negative (Vacuum) Pressure:** Connect tubing to the LOW PRESSURE port (indicated with a "-" sign) and vent the HIGH PRESSURE port (indicated with a "+" sign) to atmosphere. When operating this device in a dusty environment, install an optional A-331 filter vent plug into the vented port to keep interior clean.
- **Differential Pressure:** Connect tubing from the higher source to the HIGH PRESSURE port (indicated with a "+" sign) and from the lower source to the LOW PRESSURE port (indicated with a "-" sign).

SPECIFICATIONS

Service: Air and non-combustible, compatible gases.
Wetted Materials: Consult factory.
Housing Material: Polycarbonate.
Accuracy: ±0.5% FSO for all ranges, except 0.5 in w.c. @ ±1% FSO, and ranges at or below ±0.25 in w.c. @ ±1.5% FSO.
Stability: < ±1% / year FSO.
Pressure Limits: Ranges > 1 in w.c.: 6 psi max operation, 6 psi burst; Ranges ≤ 1 in w.c.: 3.6 psi max operation, 6 psi burst.
Temperature Limits: -4 to 158°F (-20 to 70°C).
Thermal Effects: .02% FS / °F (.036% FS / °C).
Power Requirements: 12-28 VDC or 12-28 VAC 50 to 400 Hz.
Power Consumption: 3 VA max.
Output Signal: 4-20 mA (4-wire); 0-10 V, 0-5 V, 1-5 V, and 2-10 V (4-wire).
Communication: BACnet MS/TP or Modbus® RTU.
Supported Baud Rate: 9600, 19200, 38400, 57600, 76800, 115200.
Device Load: 1/8 unit load.
Zero and Span Adjustments: Accessible via menus.
Response Time: 400 ms (damping set to 0).
Display: Backlit LCD display, LED setpoint indicators.
Electrical Connections: 15 pin male high density D-sub connection. 18" (46 cm) cable with 15 conductors included.
Process Connections: 1/8" female NPT ports on side and back.
Enclosure Rating: NEMA 4X (IP66).
Mounting Orientation: Not position sensitive.
Size: 5" OD (127 mm) x 1.9" (48 mm) deep.
Weight: 8.8 oz (250 g).
Compliance: BTL, CE.

SWITCH SPECIFICATIONS

Switch Type: 2 SPDT relays.
Electrical Rating: 1 A @ 30 VAC/VDC.
Set Point Adjustment: Accessible via menus.

MODEL CHART

Model	Range	Model	Range
DHC-002	0.25 in w.c.	DHC-208	±5 in w.c.
DHC-003	0.5 in w.c.	DHC-209	±10 in w.c.
DHC-004	1 in w.c.	DHC-053	60 Pa
DHC-006	2.5 in w.c.	DHC-055	125 Pa
DHC-008	5 in w.c.	DHC-056	250 Pa
DHC-009	10 in w.c.	DHC-253	±60 Pa
DHC-010	25 in w.c.	DHC-255	±125 Pa
DHC-011	50 in w.c.	DHC-256	±250 Pa
DHC-012	100 in w.c.	DHC-082	6 mm w.c.
DHC-202	±0.25 in w.c.	DHC-084	25 mm w.c.
DHC-203	±0.5 in w.c.	DHC-282	±6 mm w.c.
DHC-204	±1 in w.c.	DHC-284	±25 mm w.c.
DHC-206	±2.5 in w.c.		

MOUNTING

The DHC may be either panel (flush) mounted or surface mounted.

Panel Mounting Including -SS Bezel:

1. Cut a 4-9/16" (116 mm) diameter hole in the panel.
2. Insert gage and secure in place with provided screws and mounting lugs as shown in Figure 1.

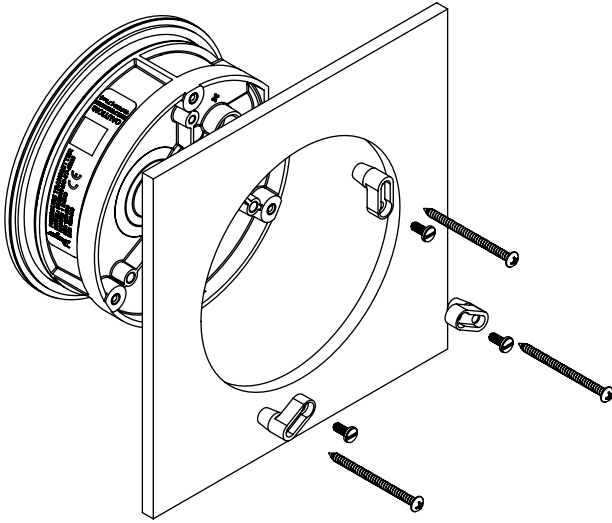

Figure 1: Panel mount

Surface Mounting

1. Use the drill template (Figure 4 on the next page) on the front of the desired mounting surface. Provide three 3/16" diameter holes in panel on a 4-1/8" diameter bolt circle. Cut the opening for the terminal block as shown in Figures 2 and 4.
2. If the rear pressure connections are to be used, also provide 1/2" diameter holes as shown in Figures 2 and 4.
3. Insert 6-32 machine screws from rear of mounting surface, threading them into tapped holes on back of transmitter and tighten.

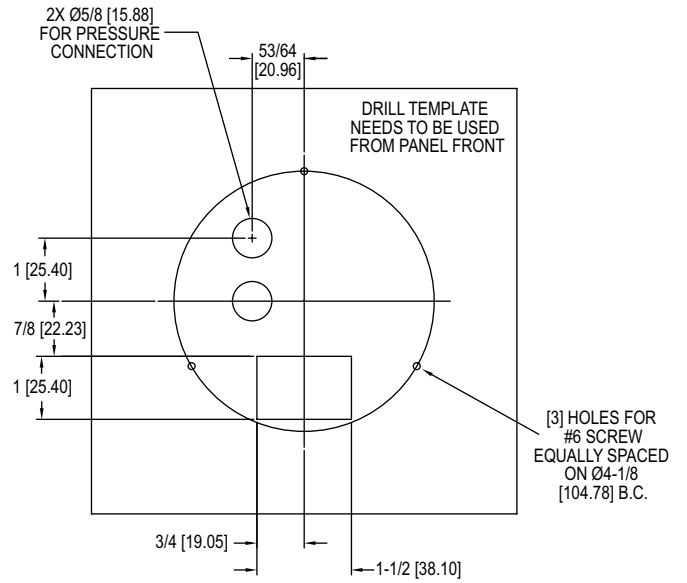

Figure 2: Surface mount

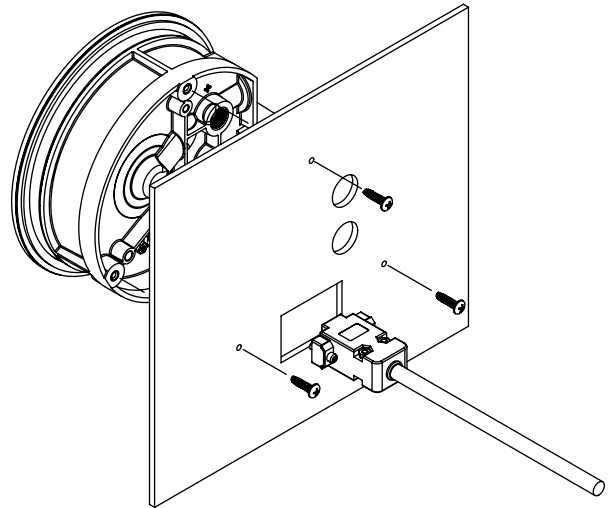

Figure 3: Surface assembly with rear pressure connections

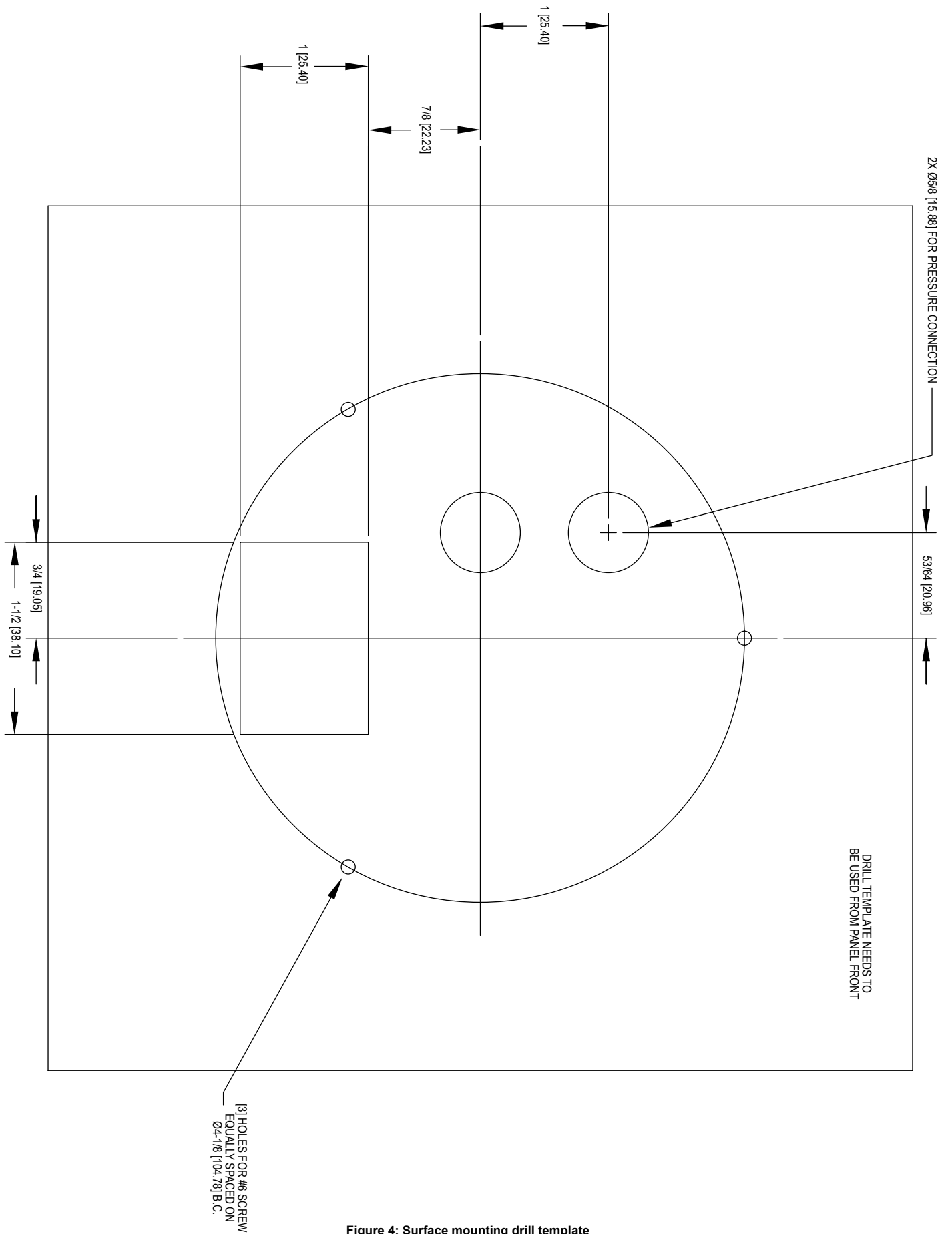

Figure 4: Surface mounting drill template

WIRING

The DHC uses a standard 15 pin male high density D-Sub connector available from most electronic distributors. A pre-wired 18" cable is included with each unit. See below table for cable color wiring information.

Function	15 Pin Connector Terminal	Cable Color
12-28 VAC/VDC Power	1	Brown
12-28 VAC/VDC Power	6	Yellow
4-20 mA Output Signal	11	Red
0-10 V Output Signal	7	Light Purple
External Input Signal	8	Light Green
Signal Common	2	Black
Relay #1 N/O	12	Violet
Relay #1 Common	13	Grey
Relay #1 N/C	14	White
Relay #2 N/O	15	Dark Blue
Relay #2 Common	10	Dark Green
Relay #2 N/C	5	Orange
RS-485 B(+)	4	Tan
RS-485 A(-)	3	Pink
RS-485 Common	9	Light Blue

NOTICE The input power polarity is unimportant.

CAUTION Wire in accordance with an equivalent national standard or code. Use copper conductors rated for 60°C. All terminals are rated CLASS 2.

ISOLATION Zones: Each zone has 500 VAC isolation from all other zones.

Zone	Inputs/Outputs
1	Power (1,6)
2	Current (2,11); Voltage (7); External Input (8)
3	Relay 1 (12,13,14)
4	Relay 2 (5,10,15)
5	RS-485 (3,4,9)

4-20 mA Transmitter – Check the specifications for the device receiving this signal for input resistance. Typical 250 to 600 Ω, 600 Ω maximum.

OPERATION

KEY FUNCTIONS					
Keys	Home Position Function	Main Menu Function	Sub Menu Function	Edit Setting Function	Edit Value Function
SP/AL	Allows access to the Set Point and Alarm menus				
MENU	Allows access to the menus	Return to home position	Return to previous menu	Cancel edit, return to sub Menu	Cancel edit, return to sub Menu
UP ARROW		Sequences through menus	Sequences through sub menus	Previous option	Increment the value
DOWN ARROW		Sequences through menus	Sequences through sub menus	Next option	Decrement the value
ENTER	Display full-scale range of unit	Enter into sub menu	Enter edit function for setting	Accept the current option	Short press: Move caron to next digit. Long Press: Accept the current value
RESET	Clear or reset an Alarm (alarm set for manual reset)		Peak/Valley sub menu resets display to present value		

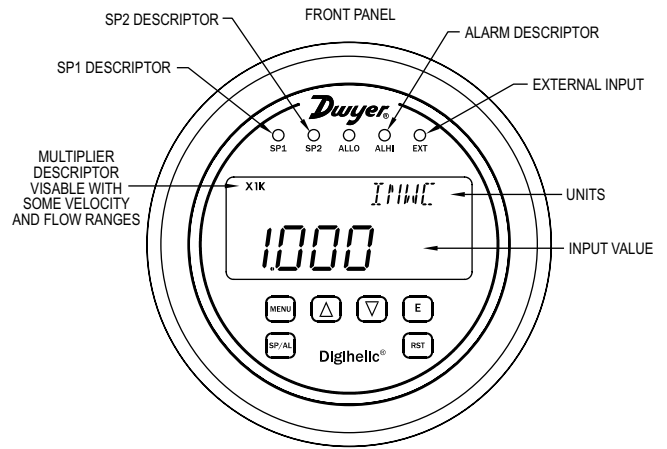

Setting Set Points and Alarms

The **SP/AL** hot key provides direct access to the Set Point and Alarm MENU. The Set Point and Alarm MENUS that are displayed are based upon the Set Point (SP) and Alarm (AL) SUB MENUS. Reference the **"SPAL MENU"** diagram under the **Menu Structure** section for the complete menu structure.

Set Point Adjustment

Adjusting the DHC set points is quick and simple. Instead of setting a set point and deadband, simply adjust "SP1T" or "SP2T" for the desired trigger point, and then adjust "SP1R" or "SP2R" for the desired reset point. The associated LED will light up green when the set point is triggered.

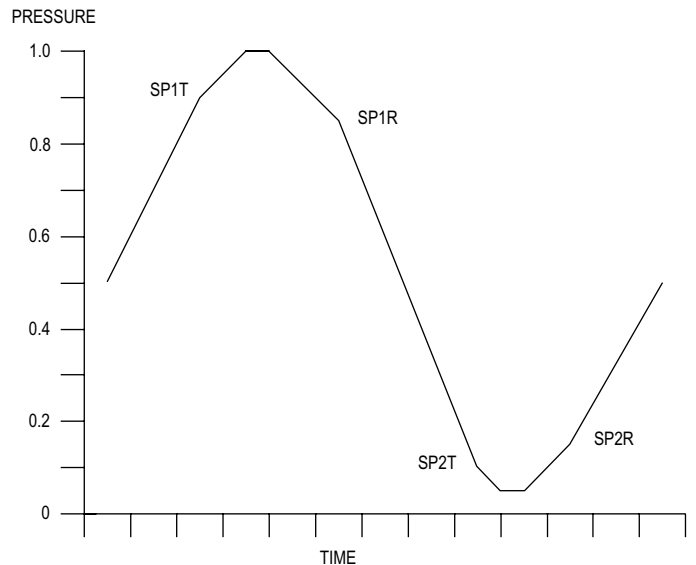

Figure 5: Set points

Using Figure 5 as an example, an instrument with a 1 in w.c. range would have the set point 1 turn on at 0.9 in w.c. and off at 0.85 in w.c. SP1T sets the turn on point and SP1R sets the turn off point. This represents a typical rising pressure set point. The second portion shows set point 2 turn on at 0.1 in w.c. and off at 0.15 in w.c. SP2T sets the turn on point, and SP2R sets the turn off point. This represents a typical falling pressure set point. Either set point can trigger a relay if selected in the rLy1 or rLy2 menus.

MAIN MENU AND SUBMENUS

Main Menu Selections (Upper Right Display Reads MENU)

- Pin - Set a custom pin code to lock out access to all menu settings
- oPEr Operation - Selection of pressure, velocity or flow mode, display units and output scaling
- SP Set Point - Enable/disable set points
- AL Alarm - Enable/disable alarm limits, other alarm settings
- rLy Relay - Configure relay source and action when active
- inP Input - Configure external input
- diS Display - Monitor and adjust display related settings: Peak, valley, % output and dampening
- Conn Connection - Configure RS-485 serial parameters and protocol
- CAL Calibration - Perform user zero and span, restore factory default settings, view device serial number

Pin - SUB MENU

In order to prevent unauthorized modification of settings, a pin number can be configured. Pin entry is enabled when the configured pin number is anything other than 0000.

oPEr (Operation) MAIN MENU

The oPEr MENU contains SUB MENUS that select the operating mode, display unit, and analog output scaling of the instrument.

The SUB MENUS are:

- ≡odE - Mode
- Unit - Display Unit
- POL - Pressure Output Low
- POH - Pressure Output High
- KFAC - Velocity K-Factor
- VOL - Velocity Output Low
- VOH - Velocity Output High
- AREA - Duct Area
- FOL - Flow Output Low
- FOH - Flow Output High
- uoUt - Voltage Output Range

If the instrument mode is set to Pressure, the oPEr MENU will include the POL and POH SUB MENUS. If the instrument mode is set to Velocity, the oPEr MENU will include the KFAC, VOL and VOH SUB MENUS. If the instrument mode is set to Flow, the oPEr MENU will include KFAC, AREA, FOL and FOH SUB MENUS. These menus will be discussed under their respective sections following the **Unit (Velocity) SUB MENU** and **Unit (Flow) SUB MENUS** sections.

≡odE (Mode) SUB MENU

Set the mode of operation of the instrument.

- PRES - Pressure
- VEL - Velocity
- FLOW - Flow

Unit(Pressure) SUB MENU

For pressure mode, the following units are available:

- INWC - Inches of water column
- FTWC - Feet of water column
- MMWC - Millimeters of water column
- CMWC - Centimeters of water column
- PSI - Pounds per square inch
- INHG - Inches of mercury
- MMHG - Millimeters of mercury
- MBAR - Millibar
- PA - Pascal
- KPA - Kilopascals
- HPA - Hectopascals
- OZIN - Ounce inches

PRESSURE RANGE VS. AVAILABLE UNITS											
INWC	FTWC	MMWC	CMWC	PSI	INHG	MMHG	MBAR	PA	KPA	HPA	OZIN
.1000		2.540	.2540			.1868	.2491	24.91		.2491	
.2500		6.350	.6350			.4671	.6227	62.27		.6227	.1445
.5000		12.70	1.270			.9342	1.245	124.5	.1245	1.245	.2890
1.000		25.40	2.540			1.868	2.491	249.1	.2491	2.491	.5780
2.500	.2083	63.50	6.350		.1839	4.671	6.227	622.7	.6227	6.227	1.445
5.000	.4167	127.0	12.70	.1806	.3678	9.342	12.45	1245	1.245	12.45	2.890
10.00	.8333	254.0	25.40	.3613	.7356	18.68	24.91	2491	2.491	24.91	5.780
25.00	2.083	635.0	63.50	.9032	1.839	46.71	62.27	6227	6.227	62.27	14.45
50.00	4.167	1270	127.0	1.806	3.678	93.42	124.5		12.45	124.5	28.90
100.0	8.333	2540	254.0	3.613	7.356	186.8	249.1		24.91	249.1	57.80

Unit (Velocity) SUB MENU

For velocity measurement, the following units are available:

- SFPM - Standard feet per minute
- M/S - Meters per second

AVAILABLE VELOCITY RANGES		
Input Range in w.c.	SCFM Range	M/S Range
±0.25	±20.02 x1K	±101.7
±0.5	±28.31 x1K	±143.8
±1.0	±40.04 x1K	±203.4
±2.5	±63.31 x1K	±321.6
±5.0	±89.53 x1K	±454.8
±10.0	±126.6 x1K	±643.2
±25.0	±200.2 x1K	±1017
±50.0	±283.1 x1K	±1438
±100.0	±400.4 x1K	±2034

NOTICE Air velocity and flow readings are based upon standard dry air conditions with an ambient temperature of 70°F and a barometric pressure of 29.92 INHG. Maximum velocity range is obtained with K-Factor set to maximum value (9.999).

Unit (Flow) SUB MENU

For flow measurements the following units are available:

- SCFM - Standard cubic feet per minute
- M³/H - Cubic meters per hour

The Available Flow Ranges table below shows the flow ranges available with the maximum duct size and K-Factor selected for each input range.

AVAILABLE FLOW RANGES		
Input Range in w.c.	SCFM Range	M ³ /H Range
±0.25	±500.5 x1K	±850.4 x1K
±0.5	±707.8 x1K	±1.203 x1M
±1.0	±1.001 x1M	±1.701 x1M
±2.5	±1.583 x1M	±2.689 x1M
±5.0	±2.238 x1M	±3.893 x1M
±10.0	±3.165 x1M	±5.378 x1M
±25.0	±4.005 x1M	±8.504 x1M
±50.0	±7.078 x1M	±12.03 x1M
±100.0	±10.01 x1M	±17.01 x1M

POL and POH SUB MENUS

Pressure output low and pressure output high are used to scale the current and voltage output. Set POL to the desired display reading for 4 mA output. Set POH to the desired display reading for 20 mA output. POL can be greater than POH. In this situation, the analog outputs are reverse acting.

KFAC SUB MENU

The K-Factor sub menu becomes accessible if the instrument mode is set to Velocity or Flow. When the DHC is used with a Pitot tube, the manufacturer may specify a K-Factor. The adjustment range is 0.001 to 9.999. The factory setting is 1.

VOL and VOH SUB MENUS

Velocity output low and velocity output high are used to scale the current and voltage output. Set VOL to the desired display reading for 4 mA output. Set VOH to the desired display reading for 20 mA output. VOL can be greater than VOH. In this situation, the analog outputs are reverse acting.

AREA SUB MENU

The Area sub menu becomes accessible if the instrument mode is set to Flow. The duct area is specified in either ft² or m² depending on the flow unit selected. The adjustment range is 0.13-25.0 ft² (0.012-2.323 m²). The factory setting is 1 ft² (0.093 m²).

FOL and FOH SUB MENUS

Flow output low and flow output high are used to scale the current and voltage output. Set FOL to the desired display reading for 4 mA output. Set FOH to the desired display reading for 20 mA output. FOL can be greater than FOH. In this situation, the analog outputs are reverse acting.

uoUt (Voltage Output Range) SUB MENU

The voltage output range setting allows the voltage output limits to be configured to 1 of 4 common ranges. Available options include: 0-10 V, 0-5 V, 1-5 V, and 2-10 V. The factory setting is 0-10 V.

SP (Set Point) MAIN MENU

The SP MENU allows the individual set points to be enabled or disabled. The SUB MENUS are:

- SP1 - Set Point 1 Enable
- SP2 - Set Point 2 Enable

SP1 (Set Point 1 Enable) SUB MENU

Enable/disable set point 1. When enabled (ON), the set point 1 trigger and reset SUB MENUS will appear in the SPAL menu. The factory setting is ON.

SP2 (Set Point 2 Enable) SUB MENU

Enable/disable set point 2. When enabled (ON), the set point 2 trigger and reset SUB MENUS will appear in the SPAL menu. The factory setting is ON.

AL (Alarm) MAIN MENU

The AL MENU allows the features of the alarm to be configured. The SUB MENUS are:

- ALHi - Alarm High Limit Enable
- ALLo - Alarm Low Limit Enable
- ALrE - Alarm Reset Type
- ALiH - Alarm Inhibit Enable
- ALDL - Alarm Delay Time

ALHi (Alarm High Limit Enable) SUB MENU

Enable/disable the alarm high limit. When enabled (ON), the alarm high limit (ALHi) SUB MENU will appear in the SPAL menu. The factory setting is ON.

ALLo (Alarm Low Limit Enable) SUB MENU

Enable/disable the alarm low limit. When enabled (ON), the alarm low limit (ALLo) SUB MENU will appear in the SPAL menu. The factory setting is ON.

ALrE (Alarm Reset Type) SUB MENU

- AUTO - Automatic reset (factory setting)
- HOLD - Manual reset. An alarm is reset by the RESET key on the front panel.

ALiH (Low Alarm Inhibit) SUB MENU

- ON - Alarm inhibit is on
- OFF - Alarm inhibit is off (factory setting)

If ALiH is selected ON, a low alarm condition is suspended upon power up until the process value passes through the alarm set point once.

ALDL (Alarm Delay) SUB MENU

Sets the amount of time an alarm condition must be continuously met before the alarm condition is recognized. The alarm delay is adjustable from 0-3600 seconds. The factory setting is 0.

rLy (Relay) MAIN MENU

The rLy menu includes options to configure which source will trigger a relay and what happens when a relay is triggered. The SUB MENUS are:

- rLy1 - Relay 1 Source
- rLy2 - Relay 2 Source
- r1At - Relay 1 Action
- r2At - Relay 2 Action

rLy1, rLy2 (Relay 1 Source, Relay 2 Source) SUB MENUS

- OFF - Relay not used
- SP1 - Set Point 1
- SP2 - Set Point 2
- AL - Either Alarm
- ALHI - High Alarm
- ALLO - Low Alarm
- EXT - External Input

The selected source determines when the relay is active. If the source is active, the relay will be active.

r1At, r2At (Relay 1 Action, Relay 2 Action) SUB MENUS

- DIR - Direct Acting/CLSE - Close on Active
- REV - Reverse Acting/OPEN - Open on Active

The selected action determines what happens when the relay is active. If the selected source is an alarm, then the options are CLSE and OPEN.

inP (Input) MAIN MENU

The inP MENU allows the features of the external input to be configured. The SUB MENUS are:

- inP - External Input Enable
- tyPE - External Input Type
- DLY - External Input Delay

inP (External Input Enable) SUB MENU

- ON - External input enabled (factory setting)
- OFF - External input disabled

tyPE (External Input Type) SUB MENU

- NO - Normally Open (factory setting)
- NC - Normally Closed

DLY (External Input Delay) SUB MENU

Sets the amount of time the external input must be continuously active before it is considered active. The delay is adjustable from 0-3600. The factory setting is 0.

diS (Display) MAIN MENU

- PEAK - Peak value
- VALY - Valley value
- PdiS - Process display
- DAMP - Damping Time

PEAK (Peak) SUB MENU

The Peak feature stores the highest process reading the instrument has measured since the last reset or power up. At power up PEAK is reset to the present pressure reading. To manually reset the PEAK value, press the RESET key while in the PEAK SUB MENU.

VALY (Valley) SUB MENU

The valley feature stores the lowest process reading the instrument has measured since the last reset or power up. At power up VALY is reset to the present pressure reading. To manually reset the VALY value, press the RESET key while in the VALY SUB MENU.

PdiS (Process Display) SUB MENU

- STD - Display reads pressure, velocity, or flow values
- PCT - Display reads % of full-scale value

When the display is reading percent, PCT is displayed in the upper right of the display.

DAMP (Damping) SUB MENU

The damping time can be adjusted from 0 to 30 seconds.

Damping stabilizes the display and outputs from instabilities due to circumstances such as vibration and excessive pressure fluctuations. Adjust the damping value until the display reads a stable value for the application.

Conn (Connection) MAIN MENU

The Conn menu contains SUB MENUS to configure the RS-485 serial parameters and selected protocol. The SUB MENUS are:

- Prot - Protocol
- ADDR - Protocol Address
- bAUd - Serial Baud Rate
- PAr - Serial Parity
- StP - Serial Stop Bits

Prot (Protocol) SUB MENU

- MOD - Modbus® Communication (factory setting)
- BAC - BACnet Communication
- NONE - Communication disabled

ADDR (Protocol Address) SUB MENU

This value sets the RS-485 device address. See the table below for protocol specific ranges. The factory setting is 127. SUB MENU not available if protocol is NONE.

Protocol	Range
Modbus®	1-247
BACnet	0-127

bAUd (Serial Baud Rate) SUB MENU

- 96 - 9600 bps
- 192 - 19200 bps
- 384 - 38400 bps
- 576 - 57600 bps
- 768 - 76800 bps
- 1152 - 115200 bps
- AUTO - Auto-baud (factory setting)

If the selected protocol is Modbus® communication, the AUTO setting will also determine the serial parity and serial stopbits. If selected communication protocol is BACnet, serial parity and serial stop bits are fixed to NONE and 1 respectively. SUB MENU not available if protocol is NONE.

PAr (Serial Parity) SUB MENU

- EVEN - Even Parity (factory setting)
- ODD - Odd Parity
- NONE - No Parity

SUB MENU not available if protocol is NONE or BAC or if serial baud rate is AUTO.

StP (Serial Stop Bits) SUB MENU

- 1 - One stop bit
- 2 - Two stop bits

SUB MENU not available if protocol is NONE or BAC or if serial baud rate is AUTO.

CAL (Calibration) Main Menu

The CAL menu contains SUB MENUS to perform field calibration, reset settings, and display information. The SUB MENUS are:

- ZERO - Zero Calibration
- SPAN - Span Calibration
- rSt - Reset Factory Defaults
- Sn 1 - Display Serial Number part 1
- Sn 2 - Display Serial Number part 2

ZERO (Zero Calibration) SUB MENU

For accurate calibration, do not apply any pressure when performing this function. Press and hold the ENTER button until the process value is cleared. The display will show a dash in each digit starting with the left most position. After 4 dashes have been displayed, the process value will be displayed and the new zero will be applied. For best results, perform the zeroing function in the same orientation you will mount the DHC.

SPAN (Span Calibration) SUB MENU

For an accurate calibration, perform a Zero calibration first. The pressure to apply will depend on the selected mode and the POH, VOH or FOH value. Apply a stable pressure equal to the configured output high value. Press and hold the ENTER button until the process value is cleared. The display will show a dash in each digit starting with the left most position. After 4 dashes have been displayed, the process value will be displayed and the new span will be applied. If the span cannot be applied, a FAIL message will be displayed. This error could occur if the applied pressure is too low or too high.

rSt (Reset Factory Defaults) SUB MENU

- NO - Do nothing
- YES - Reset all settings, clear user calibration

After selecting YES the instrument will reboot itself.

Sn 1, Sn 2 (Serial Number Display) SUB MENUS

The serial number of the instrument can be viewed on the display using these menus. The first 4 characters are available with Sn 1 and the second 4 characters are available with Sn 2.

SPAL (Set Point/Alarm) MENU

The SPAL menu contains the set point trigger and reset value as well as the alarm limits. This menu is accessible from the home screen with the SPAL button. If both set points and both alarm limits are disabled, then the SPAL menu will contain no SUB MENUS and pressing the SPAL button will not do anything. The SUB MENUS are:

- SP1T - Set Point 1 Trigger
- SP1R - Set Point 1 Reset
- SP2T - Set Point 2 Trigger
- SP2R - Set Point 2 Reset
- ALLO - Alarm Low Limit
- ALHI - Alarm High Limit

SP1T, SP2T (Set Point Trigger) SUB MENUS

These SUB MENUS set the trigger value for each set point. When the process value equals the set point trigger value, the set point is considered active. These SUB MENUS are only present if their corresponding enable setting is set to ON.

SP1R, SP2R (Set Point Reset) SUB MENUS

These SUB MENUS set the reset value for each set point. When the process value equals the set point reset value, the set point is considered inactive. These SUB MENUS are only present if their corresponding enable setting is set to ON.

ALLO (Alarm Low Limit) SUB MENU

This SUB MENU sets the alarm low limit value. If the process value is less than the alarm low limit value, the low alarm is considered active.

ALHI (Alarm High Limit) SUB MENU

This SUB MENU sets the alarm high limit value. If the process value is greater than the alarm high limit value, the high alarm is considered active.

The range of the alarm limits depends on the selected mode. If both low and high alarm limits are enabled, they cannot be closer than 2% of full-scale to each other. The dead bands of the alarm limits are fixed at 1% of full-scale.

AUTO SERIAL CONFIGURATION

Auto serial configuration enables the device to determine the baud rate, parity and stop bits directly from the serial traffic. This allows a device to be quickly and easily deployed after a valid RS-485 MAC address is chosen. Note that the auto configuration procedure assumes a serial configuration appropriate to the selected protocol as follows:

SUPPORTED SERIAL CONFIGURATIONS				
Protocol	Supported Baud Rates	Data Size	Parity	Stop Bits
BACnet - MS/TP	9600	8	None	1
Modbus® - RTU	19200		Even	
	38400	Odd		
	57600	None		
	78600	None	2	
	115200			

When Modbus® communications protocol is selected, and the device is setup offline or away from the main network, it is necessary to generate traffic in order to configure the serial communication. Attempting to read input registers is a good method to generate traffic. Note that while serial configuration is in progress, the device may not respond to requests. The device may require multiple read requests to complete the serial configuration process.

The auto serial configuration process will complete once a message addressed to the device is received and processed successfully. The serial configuration parameters are then saved to non-volatile storage and loaded by default each time the device starts. If the serial configuration of the bus changes, a power cycle of the device is required to restart the auto serial configuration process.

BACnet Communication Protocol Services

Device Communication Control Service (DM-DCC-B)

This device supports the Device Communication Control Service BIBB. The optional time duration in minutes is also supported. This device is configured with a password that must be provided to successfully execute this command. **The password is "Dwyer"**.

Reinitialize Device Service (DM-RD-B)

This device supports the Reinitialize Device Service BIBB. The supported device states are COLDSTART and WARMSTART. All other states return error. This device is configured with a password that must be provided to successfully execute this command. **The password is "Dwyer"**.

BACnet Communication Protocol Objects Overview

The instrument supports the following objects:

SUPPORTED BACNET COMMUNICATION PROTOCOL OBJECTS				
Object Type	Dynamically Creatable	Dynamically Deletable	Object Identifier	Object Name
Device	No	No	607xxx	DHC 607xxx
Analog Input	No	No	AI1	Pressure
Analog Value	No	No	AV1	Velocity
Analog Value	No	No	AV2	Flow
Analog Value	No	No	AV3	Peak
Analog Value	No	No	AV4	Valley
Analog Value	No	No	AV5	Velocity K-Factor
Analog Value	No	No	AV6	Flow Area
Analog Value	No	No	AV7	Process Output Low
Analog Value	No	No	AV8	Process Output High
Analog Value	No	No	AV9	Set Point 1 Trigger Value
Analog Value	No	No	AV10	Set Point 1 Reset Value
Analog Value	No	No	AV11	Set Point 2 Trigger Value
Analog Value	No	No	AV12	Set Point 2 Reset
Analog Value	No	No	AV13	Alarm High limit
Analog Value	No	No	AV14	Alarm Low Limit
Multi-State Value	No	No	MSV1	Process Mode
Multi-State Value	No	No	MSV2	Voltage Output Range
Multi-State Value	No	No	MSV3	Relay 1 Source
Multi-State Value	No	No	MSV4	Relay 1 Action
Multi-State Value	No	No	MSV5	Relay 2 Source
Multi-State Value	No	No	MSV6	Relay 2 Action
Multi-State Value	No	No	MSV7	External Input Type
Binary Value	No	No	BV1	Enable Set Point 1
Binary Value	No	No	BV2	Set Point 1 Status
Binary Value	No	No	BV3	Enable Set Point 2
Binary Value	No	No	BV4	Set Point 2 Status
Binary Value	No	No	BV5	Enable Alarm High Limit
Binary Value	No	No	BV6	Alarm High Limit Status
Binary Value	No	No	BV7	Enable Alarm Low Limit
Binary Value	No	No	BV8	Alarm Low Limit Status
Binary Value	No	No	BV9	Manual Alarm Reset
Binary Value	No	No	BV10	Power Up Alarm Inhibit
Binary Value	No	No	BV11	Enable External Input
Binary Value	No	No	BV12	External Input Status
Positive	No	No	PIV1	Alarm Delay
Integer Value				
Positive	No	No	PIV2	External Input Activation Delay
Integer Value				
Positive	No	No	PIV3	Damping Time
Integer Value				

Note: The default object identifier is 607xxx, where xxx is replaced by the MS/TP MAC address set in the ADDR SUB MENU under the Conn MENU. The object identifier value will change as the MS/TP MAC address changes. However, if a specific object identifier is written via BACnet communication protocol, then that value is stored and changes to the MS/TP MAC address will no longer affect the object identifier. Similarly, the default object name includes 607xxx. The object name will reflect the current object identifier. If a specific object name is written via BACnet communication protocol, then that value is stored and changes to the object identifier will no longer affect the object name.

BACnet Communication Protocol Objects

Device Object

Property	Default Value	Property Data Type	Access
Object Identifier	607127	BACnet Object Identifier	Read/Write
Object Name	"DHC 607127"	Character String(32)	Read/Write
Object Type	Device	BACnet Object Type	Read
System Status	Operational	BACnet Device Status	Read
Vendor Name	"Dwyer Instruments, LLC."	Character String	Read
Vendor Identifier	607	Unsigned	Read
Model Name	"DHC-xxx-xxx"	Character String	Read
Firmware Version	"x.x"	Character String	Read
Application Software Version	"x.x.x"	Character String	Read
Location	""	Character String(32)	Read/Write
Description	""	Character String(32)	Read/Write
Protocol Version	1	Unsigned	Read
Protocol Revision	16	Unsigned	Read
Protocol Services Supported	See PICS	BACnet Services Supported	Read
Protocol Object Types Supported	See Table Above	BACnet Object Types Supported	Read
Object List	See Table Above	BACnet Array	Read
Maximum APDU Length Accepted	480	Unsigned	Read
Segmentation Supported	No Segmentation	BACnet Segmentation	Read
APDU Timeout	0	Unsigned	Read
Number of APDU Retires	0	Unsigned	Read
Max Master	127	Unsigned	Read/Write
Max Info Frames	1	Unsigned	Read
Device Address Binding	{}	BACnet Address Binding	Read
Database Revision	0	Unsigned	Read
Property List	This Table	BACnet Array[N] of BACnet Property Identifier	Read
Serial Number	"xxxxxx"	Character String	Read

Analog Input - Pressure

This object represents the current pressure reading in the selected unit of measure. The pressure unit is set via the units property and is independent of the display unit.

Property	Default Value	Property Data Type	Access
Object Identifier	A11	BACnet Object Identifier	Read
Object Name	"Pressure"	Character String	Read
Object Type	Analog Input	BACnet Object Type	Read
Preset Value	Current Reading	Real	Read
Status Flags	{0,0,0,0}	BACnet Status Flags	Read
Event State	Normal	BACnet Event State	Read
Reliability	No Fault Detected	BACnet Reliability	Read
Out Of Service	FALSE	Boolean	Read/Write
Units	*Model Specific	BACnet Engineering Units	Read/Write

Supported pressure units:

- inches-of-water(58)
- feet-of-water*(530)
- millimeters-of-water(206)
- centimeters-of-water(57)
- pounds-force-per-square-inch(56)
- inches-of-mercury(61)
- millibars(134), pascals(53)
- hectopascals(133)
- kilopascals(54)
- ounce-force-per-square-inch*(531)

*Non-standard unit

Analog Value - Velocity

This object represents the current velocity reading in the selected unit measure. The velocity unit is set via the units property and is independent of the display unit.

Property	Default Value	Property Data Type	Access
Object Identifier	AV1	BACnet Object Identifier	Read
Object Name	"Velocity"	Character String	Read
Object Type	Analog Value	BACnet Object Type	Read
Preset Value	Current Reading	Real	Read
Status Flags	{0,0,0,0}	BACnet Status Flags	Read
Event State	Normal	BACnet Event State	Read
Reliability	No Fault Detected	BACnet Reliability	Read
Out Of Service	FALSE	Boolean	Read/Write
Units	*Model Specific	BACnet Engineering Units	Read/Write

Supported velocity units:

- feet-per-minute(77)
- meters-per-second(74)

Analog Value - Flow

This object represents the current flow reading in the selected unit measure. The flow unit is set via the units property and is independent of the display unit.

Property	Default Value	Property Data Type	Access
Object Identifier	AV2	BACnet Object Identifier	Read
Object Name	"Flow"	Character String	Read
Object Type	Analog Value	BACnet Object Type	Read
Preset Value	Current Reading	Real	Read
Status Flags	{0,0,0,0}	BACnet Status Flags	Read
Event State	Normal	BACnet Event State	Read
Reliability	No Fault Detected	BACnet Reliability	Read
Out Of Service	FALSE	Boolean	Read/Write
Units	Process Value Unit	BACnet Engineering Units	Read

Supported flow units:

- cubic-feet-per-minute(84)
- cubic-meters-per-hour(135)

Analog Value - Peak

This object represents the maximum process value measured since the last power cycle or reset. The unit of measure matches the selected process value. This value cannot be reset remotely.

Property	Default Value	Property Data Type	Access
Object Identifier	AV3	BACnet Object Identifier	Read
Object Name	"Peak"	Character String	Read
Object Type	Analog Value	BACnet Object Type	Read
Preset Value	Current Reading	Real	Read
Status Flags	{0,0,0,0}	BACnet Status Flags	Read
Event State	Normal	BACnet Event State	Read
Reliability	No Fault Detected	BACnet Reliability	Read
Out Of Service	FALSE	Boolean	Read/Write
Units	Process Value Unit	BACnet Engineering Units	Read

Analog Value - Valley

This object represents the minimum process value measured since the last power cycle or reset. The unit of measure matches the selected process value. This value cannot be reset remotely.

Property	Default Value	Property Data Type	Access
Object Identifier	AV4	BACnet Object Identifier	Read
Object Name	"Valley"	Character String	Read
Object Type	Analog Value	BACnet Object Type	Read
Preset Value	Current Reading	Real	Read
Status Flags	{0,0,0,0}	BACnet Status Flags	Read
Event State	Normal	BACnet Event State	Read
Reliability	No Fault Detected	BACnet Reliability	Read
Out Of Service	FALSE	Boolean	Read/Write
Units	Process Value Unit	BACnet Engineering Units	Read

Analog Value - Velocity K-Factor

This object represents the Velocity K-Factor setting. When the instrument is used with a Pitot tube, the manufacturer may specify a K-Factor in order to properly convert differential pressure to velocity.

Property	Default Value	Property Data Type	Access
Object Identifier	AV5	BACnet Object Identifier	Read
Object Name	"Velocity K-Factor"	Character String	Read
Object Type	Analog Value	BACnet Object Type	Read
Preset Value	1.0	Real	Read/Write
Status Flags	{0,0,0,0}	BACnet Status Flags	Read
Event State	Normal	BACnet Event State	Read
Reliability	No Fault Detected	BACnet Reliability	Read
Out Of Service	FALSE	Boolean	Read/Write
Units	no-units	BACnet Engineering Units	Read
Max Pres Value	9.999	Real	Read
Min Pres Value	0.001	Real	Read

Analog Value - Flow Area

This object represents the cross sectional area of the duct where flow is to be measured. The area is specific in either ft² or m² depending on the flow unit selected. The adjustment range is 0.13-25.0 ft² (0.012-2.323 m²). The factory setting is 1 ft² (0.093 m²).

Property	Default Value	Property Data Type	Access
Object Identifier	AV6	BACnet Object Identifier	Read
Object Name	"Flow Area"	Character String	Read
Object Type	Analog Value	BACnet Object Type	Read
Preset Value	1.0 (0.093)	Real	Read/Write
Status Flags	{0,0,0,0}	BACnet Status Flags	Read
Event State	Normal	BACnet Event State	Read
Reliability	No Fault Detected	BACnet Reliability	Read
Out Of Service	FALSE	Boolean	Read/Write
Units	square-feet (square-meters)	BACnet Engineering Units	Read
Max Pres Value	25.0 (2.323)	Real	Read
Min Pres Value	0.13 (0.093)	Real	Read

Multi-State Value - Process Mode

This object represents the process or operating mode of the instrument. This setting determines which process variable is output on the analog channels and measurement unit of the peak, valley, set points and alarm limits.

Property	Default Value	Property Data Type	Access
Object Identifier	MSV1	BACnet Object Identifier	Read
Object Name	"Process Mode"	Character String	Read
Object Type	Multi-State Value	BACnet Object Type	Read
Preset Value	1	Unsigned	Read/Write
Status Flags	{0,0,0,0}	BACnet Status Flags	Read
Event State	Normal	BACnet Event State	Read
Reliability	No Fault Detected	BACnet Reliability	Read
Out Of Service	FALSE	Boolean	Read/Write
Number of States	3	Unsigned	Read
State Text	"Pressure", "Velocity", "Flow"	BACnet Array[N] of Character String	Read

Analog Value - Process Output Low

This object represents the process value at which the analog output channels will be at their minimum value. The unit of this value matches the unit of the selected process mode.

Property	Default Value	Property Data Type	Access
Object Identifier	AV7	BACnet Object Identifier	Read
Object Name	"Process Output Low"	Character String	Read
Object Type	Analog Value	BACnet Object Type	Read
Preset Value	Model Specific	Real	Read/Write
Status Flags	{0,0,0,0}	BACnet Status Flags	Read
Event State	Normal	BACnet Event State	Read
Reliability	No Fault Detected	BACnet Reliability	Read
Out Of Service	FALSE	Boolean	Read/Write
Units	Mode Specific	BACnet Engineering Units	Read
Max Pres Value	Model Specific	Real	Read
Min Pres Value	Model Specific	Real	Read

Analog Value - Process Output High

This object represents the process value at which the analog output channels will be at their maximum value. The unit of this value matches the unit of the selected process mode.

Property	Default Value	Property Data Type	Access
Object Identifier	AV8	BACnet Object Identifier	Read
Object Name	"Process Output High"	Character String	Read
Object Type	Analog Value	BACnet Object Type	Read
Preset Value	Model Specific	Real	Read/Write
Status Flags	{0,0,0,0}	BACnet Status Flags	Read
Event State	Normal	BACnet Event State	Read
Reliability	No Fault Detected	BACnet Reliability	Read
Out Of Service	FALSE	Boolean	Read/Write
Units	Mode Specific	BACnet Engineering Units	Read
Max Pres Value	Model Specific	Real	Read
Min Pres Value	Model Specific	Real	Read

Multi-State Value - Voltage Output Range

This object represents the nominal range of the voltage output channel.

Property	Default Value	Property Data Type	Access
Object Identifier	MSV2	BACnet Object Identifier	Read
Object Name	"Voltage Output Range"	Character String	Read
Object Type	Multi-State Value	BACnet Object Type	Read
Preset Value	1	Unsigned	Read/Write
Status Flags	{0,0,0,0}	BACnet Status Flags	Read
Event State	Normal	BACnet Event State	Read
Reliability	No Fault Detected	BACnet Reliability	Read
Out Of Service	FALSE	Boolean	Read/Write
Number of States	4	Unsigned	Read
State Text	{"0-10V", "0-5V", "2-10V", "1-5"}	BACnet Array[N] of Character String	Read

Binary Value - Enable Set Point 1

This object represents the enable state of set point 1. When enabled, the set point 1 trigger and reset values are compared against the current process value.

Property	Default Value	Property Data Type	Access
Object Identifier	BV1	BACnet Object Identifier	Read
Object Name	"Enable Set Point 1"	Character String	Read
Object Type	Binary Value	BACnet Object Type	Read
Preset Value	Active	BACnet Binary PV	Read/Write
Status Flags	{0,0,0,0}	BACnet Status Flags	Read
Event State	Normal	BACnet Event State	Read
Reliability	No Fault Detected	BACnet Reliability	Read
Out Of Service	FALSE	Boolean	Read/Write

Analog Value - Set Point 1 Trigger Value

This object represents the process value at which set point 1 transitions from inactive to active. The unit of this value matches the unit of the selected process mode.

Property	Default Value	Property Data Type	Access
Object Identifier	AV9	BACnet Object Identifier	Read
Object Name	"Set Point 1 Trigger Value"	Character String	Read
Object Type	Analog Value	BACnet Object Type	Read
Preset Value	Model Specific	Real	Read/Write
Status Flags	{0,0,0,0}	BACnet Status Flags	Read
Event State	Normal	BACnet Event State	Read
Reliability	No Fault Detected	BACnet Reliability	Read
Out Of Service	FALSE	Boolean	Read/Write
Units	Mode Specific	BACnet Engineering Units	Read
Max Pres Value	Model Specific	Real	Read
Min Pres Value	Model Specific	Real	Read

Analog Value - Set Point 1 Reset Value

This object represents the process value at which set point 1 transitions from active to inactive. The unit of this value matches the unit of the selected process mode.

Property	Default Value	Property Data Type	Access
Object Identifier	AV10	BACnet Object Identifier	Read
Object Name	"Set Point 1 Reset Value"	Character String	Read
Object Type	Analog Value	BACnet Object Type	Read
Preset Value	Model Specific	Real	Read/Write
Status Flags	{0,0,0,0}	BACnet Status Flags	Read
Event State	Normal	BACnet Event State	Read
Reliability	No Fault Detected	BACnet Reliability	Read
Out Of Service	FALSE	Boolean	Read/Write
Units	Mode Specific	BACnet Engineering Units	Read
Max Pres Value	Model Specific	Real	Read
Min Pres Value	Model Specific	Real	Read

Binary Value - Set Point 1 Status

This object represents the current status of set point 1. When active, the SP1 LED on the instrument face is illuminated.

Property	Default Value	Property Data Type	Access
Object Identifier	BV2	BACnet Object Identifier	Read
Object Name	"Set Point 1 Status"	Character String	Read
Object Type	Binary Value	BACnet Object Type	Read
Preset Value	Inactive	BACnet Binary PV	Read
Status Flags	{0,0,0,0}	BACnet Status Flags	Read
Event State	Normal	BACnet Event State	Read
Reliability	No Fault Detected	BACnet Reliability	Read
Out Of Service	FALSE	Boolean	Read/Write

Binary Value - Enable Set Point 2

This object represents the enable state of set point 2. When enabled, the set point 2 trigger and reset values are compared against the current process value.

Property	Default Value	Property Data Type	Access
Object Identifier	BV3	BACnet Object Identifier	Read
Object Name	"Enable Set Point 2"	Character String	Read
Object Type	Binary Value	BACnet Object Type	Read
Preset Value	Active	BACnet Binary PV	Read/Write
Status Flags	{0,0,0,0}	BACnet Status Flags	Read
Event State	Normal	BACnet Event State	Read
Reliability	No Fault Detected	BACnet Reliability	Read
Out Of Service	FALSE	Boolean	Read/Write

Analog Value - Set Point 2 Trigger Value

This object represents the process value at which set point 2 transitions from inactive to active. The unit of this value matches the unit of the selected process mode.

Property	Default Value	Property Data Type	Access
Object Identifier	AV11	BACnet Object Identifier	Read
Object Name	"Set Point 2 Trigger Value"	Character String	Read
Object Type	Analog Value	BACnet Object Type	Read
Preset Value	Model Specific	Real	Read/Write
Status Flags	{0,0,0,0}	BACnet Status Flags	Read
Event State	Normal	BACnet Event State	Read
Reliability	No Fault Detected	BACnet Reliability	Read
Out Of Service	FALSE	Boolean	Read/Write
Units	Mode Specific	BACnet Engineering Units	Read
Max Pres Value	Model Specific	Real	Read
Min Pres Value	Model Specific	Real	Read

Analog Value - Set Point 2 Reset Value

This object represents the process value at which set point 2 transitions from active to inactive. The unit of this value matches the unit of the selected process mode.

Property	Default Value	Property Data Type	Access
Object Identifier	AV12	BACnet Object Identifier	Read
Object Name	"Set Point 2 Reset Value"	Character String	Read
Object Type	Analog Value	BACnet Object Type	Read
Preset Value	Model Specific	Real	Read/Write
Status Flags	{0,0,0,0}	BACnet Status Flags	Read
Event State	Normal	BACnet Event State	Read
Reliability	No Fault Detected	BACnet Reliability	Read
Out Of Service	FALSE	Boolean	Read/Write
Units	Mode Specific	BACnet Engineering Units	Read
Max Pres Value	Model Specific	Real	Read
Min Pres Value	Model Specific	Real	Read

Binary Value - Set Point 2 Status

This object represents the current status of set point 2. When active, the SP2 LED on the instrument face is illuminated.

Property	Default Value	Property Data Type	Access
Object Identifier	BV4	BACnet Object Identifier	Read
Object Name	"Set Point 2 Status"	Character String	Read
Object Type	Binary Value	BACnet Object Type	Read
Preset Value	Inactive	BACnet Binary PV	Read
Status Flags	{0,0,0,0}	BACnet Status Flags	Read
Event State	Normal	BACnet Event State	Read
Reliability	No Fault Detected	BACnet Reliability	Read
Out Of Service	FALSE	Boolean	Read/Write

Binary Value - Enable Alarm High Limit

This object represents the enable state of the alarm high limit. When enabled, the alarm high limit value is compared against the current process value.

Property	Default Value	Property Data Type	Access
Object Identifier	BV5	BACnet Object Identifier	Read
Object Name	"Enable Alarm High Limit"	Character String	Read
Object Type	Binary Value	BACnet Object Type	Read
Preset Value	Active	BACnet Binary PV	Read/Write
Status Flags	{0,0,0,0}	BACnet Status Flags	Read
Event State	Normal	BACnet Event State	Read
Reliability	No Fault Detected	BACnet Reliability	Read
Out Of Service	FALSE	Boolean	Read/Write

Analog Value - Alarm High Limit

This object represents the process value at which the alarm high status transitions from inactive to active. The unit of this value matches the unit of the selected process mode. The alarm high status transitions from active to inactive at 1% full-scale less than this value.

Property	Default Value	Property Data Type	Access
Object Identifier	AV13	BACnet Object Identifier	Read
Object Name	"Alarm High Limit"	Character String	Read
Object Type	Analog Value	BACnet Object Type	Read
Preset Value	Model Specific	Real	Read/Write
Status Flags	{0,0,0,0}	BACnet Status Flags	Read
Event State	Normal	BACnet Event State	Read
Reliability	No Fault Detected	BACnet Reliability	Read
Out Of Service	FALSE	Boolean	Read/Write
Units	Mode Specific	BACnet Engineering Units	Read
Max Pres Value	Model Specific	Real	Read
Min Pres Value	Alarm Low Limit	Real	Read

Binary Value - Alarm High Limit Status

This object represents the current status of the alarm high limit. When active, the ALHI LED on the instrument face is illuminated.

Property	Default Value	Property Data Type	Access
Object Identifier	BV6	BACnet Object Identifier	Read
Object Name	"Alarm High Limit Status"	Character String	Read
Object Type	Binary Value	BACnet Object Type	Read
Preset Value	Inactive	BACnet Binary PV	Read/Write**
Status Flags	{0,0,0,0}	BACnet Status Flags	Read
Event State	Normal	BACnet Event State	Read
Reliability	No Fault Detected	BACnet Reliability	Read
Out Of Service	FALSE	Boolean	Read/Write

**The high alarm status can be reset to inactive by writing inactive to the present value property. This is allowed only if the Manual Alarm Reset is Active and the process value no longer satisfies the alarm high condition. In all other cases a BACnet communication protocol error is returned.

Binary Value - Enable Alarm Low Limit

This object represents the enable state of the alarm low limit. When enabled, the alarm low limit value is compared against the current process value.

Property	Default Value	Property Data Type	Access
Object Identifier	BV7	BACnet Object Identifier	Read
Object Name	"Enable Alarm Low Limit"	Character String	Read
Object Type	Binary Value	BACnet Object Type	Read
Preset Value	Active	BACnet Binary PV	Read/Write
Status Flags	{0,0,0,0}	BACnet Status Flags	Read
Event State	Normal	BACnet Event State	Read
Reliability	No Fault Detected	BACnet Reliability	Read
Out Of Service	FALSE	Boolean	Read/Write

Analog Value - Alarm Low Limit

This object represents the process value at which the alarm low status transitions from inactive to active. The unit of this value matches the unit of the selected process mode. The alarm low status transitions from active to inactive at 1% full-scale greater than this value.

Property	Default Value	Property Data Type	Access
Object Identifier	AV14	BACnet Object Identifier	Read
Object Name	"Alarm Low Limit"	Character String	Read
Object Type	Analog Value	BACnet Object Type	Read
Preset Value	Model Specific	Real	Read/Write
Status Flags	{0,0,0,0}	BACnet Status Flags	Read
Event State	Normal	BACnet Event State	Read
Reliability	No Fault Detected	BACnet Reliability	Read
Out Of Service	FALSE	Boolean	Read/Write
Units	Mode Specific	BACnet Engineering Units	Read
Max Pres Value	Alarm High Limit	Real	Read
Min Pres Value	Model Specific	Real	Read

Binary Value - Alarm Low Limit Status

This object represents the current status of the alarm low limit. When active, the ALLO LED on the instrument face is illuminated.

Property	Default Value	Property Data Type	Access
Object Identifier	BV8	BACnet Object Identifier	Read
Object Name	"Alarm Low Limit Status"	Character String	Read
Object Type	Binary Value	BACnet Object Type	Read
Preset Value	Inactive	BACnet Binary PV	Read/Write**
Status Flags	{0,0,0,0}	BACnet Status Flags	Read
Event State	Normal	BACnet Event State	Read
Reliability	No Fault Detected	BACnet Reliability	Read
Out Of Service	FALSE	Boolean	Read/Write

**The low alarm status can be reset to inactive by writing inactive to the present value property. This is allowed only if the Manual Alarm Reset is Active and the process value no longer satisfies the alarm low condition. In all other cases a BACnet communication protocol error is returned.

Binary Value - Manual Alarm Reset

This object represents the alarm type setting (ALrE in the menu). When active, the alarm status will remain active after the alarm condition has passed.

Property	Default Value	Property Data Type	Access
Object Identifier	BV9	BACnet Object Identifier	Read
Object Name	"Manual Alarm Reset"	Character String	Read
Object Type	Binary Value	BACnet Object Type	Read
Preset Value	Inactive	BACnet Binary PV	Read/Write
Status Flags	{0,0,0,0}	BACnet Status Flags	Read
Event State	Normal	BACnet Event State	Read
Reliability	No Fault Detected	BACnet Reliability	Read
Out Of Service	FALSE	Boolean	Read/Write

Binary Value - Power Up Alarm Inhibit

This object represents the Low Alarm Inhibit (ALiH) SUB MENU. When enabled, the process value must be greater than the alarm low limit before an alarm low condition is considered active.

Property	Default Value	Property Data Type	Access
Object Identifier	BV10	BACnet Object Identifier	Read
Object Name	"Power Up Alarm Inhibit"	Character String	Read
Object Type	Binary Value	BACnet Object Type	Read
Preset Value	Inactive	BACnet Binary PV	Read/Write
Status Flags	{0,0,0,0}	BACnet Status Flags	Read
Event State	Normal	BACnet Event State	Read
Reliability	No Fault Detected	BACnet Reliability	Read
Out Of Service	FALSE	Boolean	Read/Write

Positive Integer Value - Alarm Delay

This object represents the amount of time an alarm condition must be continuously met before the alarm status becomes active.

Property	Default Value	Property Data Type	Access
Object Identifier	PIV1	BACnet Object Identifier	Read
Object Name	"Alarm Delay"	Character String	Read
Object Type	Positive Integer Value	BACnet Object Type	Read
Preset Value	0	Unsigned	Read/Write
Status Flags	{0,0,0,0}	BACnet Status Flags	Read
Event State	Normal	BACnet Event State	Read
Reliability	No Fault Detected	BACnet Reliability	Read
Out Of Service	FALSE	Boolean	Read/Write
Units	Mode Specific	BACnet Engineering Units	Read
Max Pres Value	3600	Real	Read
Min Pres Value	0	Real	Read

Multi-State Value - Relay 1 Source

This object represents the relay 1 source setting. The selected source determines when the relay is active. If the source is active, the relay will be active.

Property	Default Value	Property Data Type	Access
Object Identifier	MSV3	BACnet Object Identifier	Read
Object Name	"Relay 1 Source"	Character String	Read
Object Type	Multi-State Value	BACnet Object Type	Read
Preset Value	2	Unsigned	Read/Write
Status Flags	{0,0,0,0}	BACnet Status Flags	Read
Event State	Normal	BACnet Event State	Read
Reliability	No Fault Detected	BACnet Reliability	Read
Out Of Service	FALSE	Boolean	Read/Write
Number of States	7	Unsigned	Read
State Text	{"Off", "Set Point 1", "Set Point 2", "Any Alarm", "Alarm High Llimit", "Alarm Low Limit", "External Input"}	BACnet Array[N] of Character String	Read

Multi-State Value - Relay 1 Action

This object represents the relay 1 action setting. The selected action determines what happens when the relay is active. If the selected source is an alarm, then the state text values are "Close" and "Open".

Property	Default Value	Property Data Type	Access
Object Identifier	MSV4	BACnet Object Identifier	Read
Object Name	"Relay 1 Action"	Character String	Read
Object Type	Multi-State Value	BACnet Object Type	Read
Preset Value	1	Unsigned	Read/Write
Status Flags	{0,0,0,0}	BACnet Status Flags	Read
Event State	Normal	BACnet Event State	Read
Reliability	No Fault Detected	BACnet Reliability	Read
Out Of Service	FALSE	Boolean	Read/Write
Number of States	2	Unsigned	Read
State Text	{"Direct", "Reverse"}	BACnet Array[N] of Character String	Read

Multi-State Value - Relay 2 Source

This object represents the relay 2 source setting. The selected source determines when the relay is active. If the source is active, the relay will be active.

Property	Default Value	Property Data Type	Access
Object Identifier	MSV5	BACnet Object Identifier	Read
Object Name	"Relay 2 Source"	Character String	Read
Object Type	Multi-State Value	BACnet Object Type	Read
Preset Value	3	Unsigned	Read/Write
Status Flags	{0,0,0,0}	BACnet Status Flags	Read
Event State	Normal	BACnet Event State	Read
Reliability	No Fault Detected	BACnet Reliability	Read
Out Of Service	FALSE	Boolean	Read/Write
Number of States	7	Unsigned	Read
State Text	{"Off", "Set Point 1", "Set Point 2", "Any Alarm", "Alarm High Llimit", "Alarm Low Limit", "External Input"}	BACnet Array[N] of Character String	Read

Multi-State Value - Relay 2 Action

This object represents the relay 2 action setting. The selected action determines what happens when the relay is active. If the selected source is an alarm, then the state text values are "Close" and "Open".

Property	Default Value	Property Data Type	Access
Object Identifier	MSV6	BACnet Object Identifier	Read
Object Name	"Relay 2 Action"	Character String	Read
Object Type	Multi-State Value	BACnet Object Type	Read
Preset Value	1	Unsigned	Read/Write
Status Flags	{0,0,0,0}	BACnet Status Flags	Read
Event State	Normal	BACnet Event State	Read
Reliability	No Fault Detected	BACnet Reliability	Read
Out Of Service	FALSE	Boolean	Read/Write
Number of States	2	Unsigned	Read
State Text	{"Direct", "Reverse"}	BACnet Array[N] of Character String	Read

Binary Value - Enable External Input

This object represents the enable state of the external input. When enabled, the external input is monitored and can be used to active a relay.

Property	Default Value	Property Data Type	Access
Object Identifier	BV11	BACnet Object Identifier	Read
Object Name	"Enable External Input"	Character String	Read
Object Type	Binary Value	BACnet Object Type	Read
Preset Value	Active	BACnet Binary PV	Read/Write
Status Flags	{0,0,0,0}	BACnet Status Flags	Read
Event State	Normal	BACnet Event State	Read
Reliability	No Fault Detected	BACnet Reliability	Read
Out Of Service	FALSE	Boolean	Read/Write

Multi-State Value - External Input Type

This object represents the type of contact/switch connected to the external input.

Property	Default Value	Property Data Type	Access
Object Identifier	MSV7	BACnet Object Identifier	Read
Object Name	"External Input Type"	Character String	Read
Object Type	Multi-State Value	BACnet Object Type	Read
Preset Value	1	Unsigned	Read/Write
Status Flags	{0,0,0,0}	BACnet Status Flags	Read
Event State	Normal	BACnet Event State	Read
Reliability	No Fault Detected	BACnet Reliability	Read
Out Of Service	FALSE	Boolean	Read/Write
Number of States	2	Unsigned	Read
State Text	{"Normally Open", "Normally Closed"}	BACnet Array[N] of Character String	Read

Positive Integer Value - External Input Activation Delay

This object represents the amount of time the external input must be continuously active before it is considered active.

Property	Default Value	Property Data Type	Access
Object Identifier	PIV2	BACnet Object Identifier	Read
Object Name	"External Input Activation Delay"	Character String	Read
Object Type	Positive Integer Value	BACnet Object Type	Read
Preset Value	0	Unsigned	Read/Write
Status Flags	{0,0,0,0}	BACnet Status Flags	Read
Event State	Normal	BACnet Event State	Read
Reliability	No Fault Detected	BACnet Reliability	Read
Out Of Service	FALSE	Boolean	Read/Write
Units	Mode Specific	BACnet Engineering Units	Read
Max Pres Value	3600	Units	Read
Min Pres Value	0	Real	Read

Binary Value - External Input Status

This object represents the current status of the external input. When active, the EXT LED on the instrument face is illuminated.

Property	Default Value	Property Data Type	Access
Object Identifier	BV12	BACnet Object Identifier	Read
Object Name	"External Input Status"	Character String	Read
Object Type	Binary Value	BACnet Object Type	Read
Preset Value	Inactive	BACnet Binary PV	Read
Status Flags	{0,0,0,0}	BACnet Status Flags	Read
Event State	Normal	BACnet Event State	Read
Reliability	No Fault Detected	BACnet Reliability	Read
Out Of Service	FALSE	Boolean	Read/Write

Positive Integer Value - Damping Time

This object represents the time, in seconds, for the process measurement to reach 99.8% of the current input value. A value of 0 disables the damping feature.

Property	Default Value	Property Data Type	Access
Object Identifier	PIV3	BACnet Object Identifier	Read
Object Name	"Damping Time"	Character String	Read
Object Type	Positive Integer Value	BACnet Object Type	Read
Preset Value	0	Unsigned	Read/Write
Status Flags	{0,0,0,0}	BACnet Status Flags	Read
Event State	Normal	BACnet Event State	Read
Reliability	No Fault Detected	BACnet Reliability	Read
Out Of Service	FALSE	Boolean	Read/Write
Units	Mode Specific	BACnet Engineering Units	Read
Max Pres Value	30	Real	Read
Min Pres Value	0	Real	Read

Modbus® Communications Protocol Overview

NOTICE Modbus® communications protocol installations should comply with Modbus® Communication Protocol over Serial Line Specification and Implementation Guide V1.02, Modbus® Organization, Inc., 2006

NOTICE Communications wiring must be in a daisy-chain fashion. Star connections and T connections are not permitted

Modbus® Communications Protocol Functions

The DHC supports the following functions.

Modbus® Communications Protocol Registers

Input Registers

The String data type is read as a stream of ASCII characters with the first character sent in the MSB of the first register and the second character sent in the LSB of the first register and so on. If the string is shorter than the allotted size, the remaining bytes will be zero padded.

INPUT REGISTERS			
Register	Description	Data Type	Range
0001-0002	Pressure	32bit float	-
0003-0004	Velocity	32bit float	-
0005-0006	Flow	32bit float	-
0007-0008	Peak	32bit float	-
0009-0010	Valley	32bit float	-
0011	Set Point 1 Status	16bit integer	0=Inactive, 1=Active
0012	Set Point 2 Status	16bit integer	0=Inactive, 1=Active
0013	External Input Status	16bit integer	0=Inactive, 1=Active
0014-0015	Error Flags	32bit integer	See Table Below
8001-8016	Model Number	String(32)	"DHC-XXX-XXX"
8017-8020	Serial Number	String(8)	"XXXXXX"
8021-8028	Firmware Version	String(16)	"X.X.X"
8029-8032	Date Code	String(8)	"XXXXXX"

Display Errors	Error Flags	
	Bit Position	Description
EADR	0	Invalid Address
ouEr	1	Over Range
Undr	2	Under Range
ER 1	3	Sensor Range Exceeded
ER 2	4	Sensor Error
ER 3	5	No Sensor
ER 4	6	User Settings Invalid
ER 5	7	Factory Settings Invalid
ER 6	8	External Memory Failure
ER 7	9	Internal Memory Failure

HOLDING REGISTERS			
Register	Description	Data Type	Range
0001-0016	Device Name	String(32)	"DHC"
0017	Process Mode	16bit integer	0=Pressure, 1=Velocity, 2=Flow
0018	Pressure Unit	16bit integer	0=inWC, 1=ftWC, 2=mmWC, 3=cmWC, 4=PSI, 5=inHG, 6=mmHg, 7=mBar, 8=Pa, 9=kPa, 10=hPa, 11=ozin
0019	Velocity Unit	16bit integer	0=ft/min, 1=m/s
0020	Flow Unit	16bit integer	0=ft ³ /min, 1=m ³ /hr
0021-0022	Velocity K-Factor	32bit float	0.001-9.999
0023-0024	Flow Area	32bit float	0.125-25ft ² (0.0116-2.3226m ²)
0025-0026	Process Output Low	32bit float	-
0027-0028	Process Output High	32bit float	-
0029	Voltage Output Range	16bit integer	0=0-10V, 1=0-5V, 2=1-5V, 3=2-10V
0030	Set Point 1 Enable	16bit integer	0=False, 1=True
0031-0032	Set Point 1 Trigger Value	32bit float	-
0033-0034	Set Point 1 Reset Value	32bit float	-
0035	Set Point 2 Enable	16bit integer	0=False, 1=True
0036-0037	Set Point 2 Trigger Value	32bit float	-
0038-0039	Set Point 2 Reset Value	32bit float	-
0040	Enable Alarm High Limit	16bit integer	0=False, 1=True
0041-0042	High Alarm Limit	32bit float	-
0043	Enable Alarm Low Limit	16bit integer	0=False, 1=True
0044-0045	Low Alarm Limit	32bit float	-
0046	Manual Alarm Reset	16bit integer	0=Disabled, 1=Enabled
0047	Power Up Alarm Inhibit	16bit integer	0=Disabled, 1=Enabled
0048	Alarm Delay	16bit integer	0-3600
0049	Alarm High Limit Status	16bit integer	0=Inactive, 1=active
0050	Alarm Low Limit Status	16bit integer	0=Inactive, 1=active
0051	Relay 1 Source	16bit integer	0=Off, 1=Set Point 1, 2=Set Point 2, 3=Any Alarm, 4=High Alarm Limit, 5=Low Alarm Limit, 6=External Input
0052	Relay 1 Action	16bit integer	0=Direct, 1=Reverse
0053	Relay 2 Source	16bit integer	0=Off, 1=Set Point 1, 2=Set Point 2, 3=Any Alarm, 4=High Alarm Limit, 5=Low Alarm Limit, 6=External Input
0054	Relay 2 Action	16bit integer	0=Direct, 1=Reverse
0055	Enable External Input	16bit integer	0=False, 1=True
0056	External Input Type	16bit integer	0=Normally Open, 1=Normally Closed
0057	External Input Activation Delay	16bit integer	0-3600
0058	Damping Time	16bit integer	0-30

Pressure/Velocity/Flow Units: The unit selected is independent of the display unit.

Alarm High/Low Limit Status: The alarm status can be reset to inactive by writing inactive to the status register. This is allowed only if Manual Alarm Reset is Enabled and the process value no longer satisfies the alarm condition. In all other cases a Modbus® communications protocol error is returned.

Multi-Address Support

Multi-address support allows a register to be read or written to using different byte orientations specified by the address range. For example, input register 0001 can also be read at 2001, 4001 and 6001 with different byte orientations as listed in the table below. Registers that do not have multi-address support are only available in Big-Endian byte orientation (Modbus® communications protocol standard).

Byte Order	Address Range	32bit Values				16bit Values	
		Register 1		Register 1		Register 1	
		MSB			LSB	MSB	LSB
Big-Endian	0001-2000	A	B	C	D	A	B
Byte Swap	2001-4000	B	A	D	C	B	A
Word Swap	4001-6000	C	D	A	B	A	B
Little-Endian	6001-8000	D	C	B	A	B	A

MAINTENANCE

Upon final installation of the Series DHC, no routine maintenance is required. The Series DHC is not field serviceable and should be returned if repair is needed. Field repair should not be attempted and may void warranty.



This symbol indicates waste electrical products should not be disposed of with household waste. Please recycle where facilities exist. Check with your Local Authority or retailer for recycling advice.

WARRANTY/RETURN

Refer to “Terms and Conditions of Sale” in our catalog and on our website. Contact customer service to receive a Return Materials Authorization (RMA) number before shipping the product back for repair. Be sure to include a brief description of the problem plus any additional application notes.

MENU MAPS

