

# CO2 & Temperature + Humidity (RS485 output) Transmitter Instruction

Thanks for choosing our product! Please read carefully and follow this instruction before using!

## Introductions

AVC-311 series is designed for measuring the ambient carbon dioxide concentration with optional measurement of temperature & humidity. It can provide signal output for environmental monitoring or control. Utilizing NDIR sensing element ensures its accuracy of measurement. Two different types for standard (0~2000ppm) and higher level (0~9999ppm) measurement range. The standard type is for building climate control, greenhouse, library, offices, shopping mall; and the high level type can be used in chemical gas factory, wine cellar, brewery and etc.

## Wiring

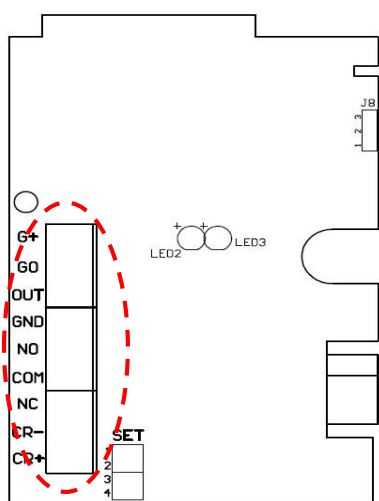

1.	G+	DC 12 ~ 36V AC 24V (50/60Hz)
2.	G0	System GND
3.	OUT	N/A
4.	GND	N/A
5.	N.O	Normally opened
6.	COM	COM
7.	N.C	Normally closed
8.	CR-	RS-485(-)
9.	CR+	RS-485(+)

## Connection

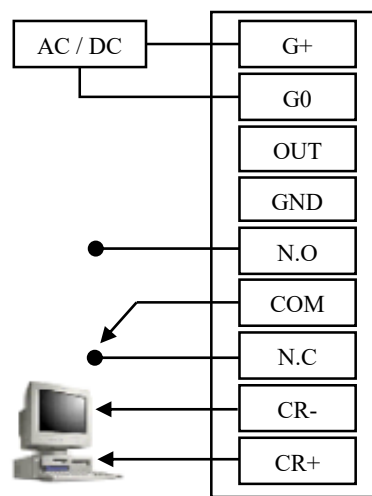

【Figure 1】

**Notice: Please remove power from the unit before wiring, in order to avoid any damage or hazard.**

## Relay output (CO2 set point alarm)

Set CO2 alarm relay output with SET2.

Relay Contact setting :

Relay Output (Hysteresis is 100ppm)		SET 2
Standard Type	High Level Type	
800 ppm	8000 ppm	
1000 ppm (Default)	9999 ppm (Default)	

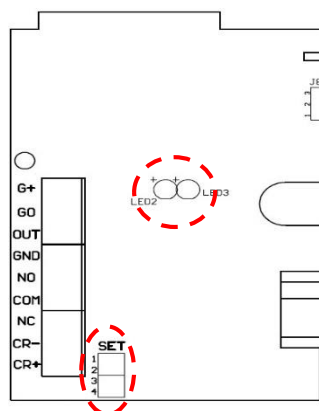

- \* When the CO2 concentration reaches the alarm setting point, LED indicator will be switched on.
- \* The standard type is for general indoor use. For any special application, such as industrial or agriculture, please contact us.
- \* Please do not use the AVC-311 series in high humidity environment.

## Display Setting

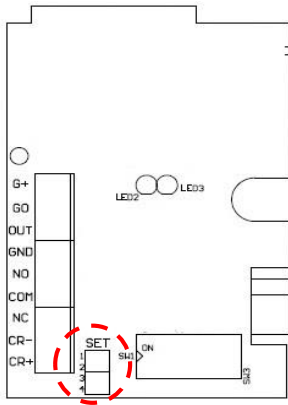

SET3 and SET4 are used to select display setting.

Short :

Open :

Display Setting	SET 3	SET 4
Humidity		
Temperature		
CO2		
Switching Humidity/ Temperature/ CO2 measurement every 5 seconds (Default)		

## Device ID setting

ID with DIP switch, ON is 1, OFF is 0

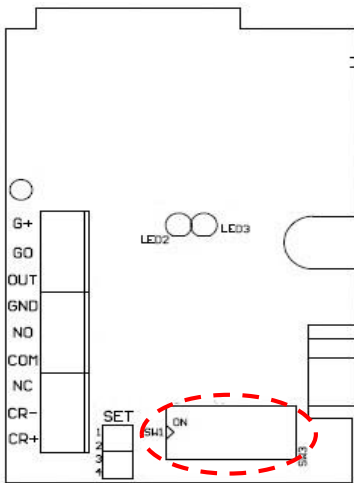

Device ID ( ON : 1, OFF : 0 )					
1	0000 0001		127	0111 1111	
2	0000 0010		128	1000 0000	
⋮	⋮	⋮	⋮	⋮	⋮
64	0100 0000		246	1111 0110	
65	0100 0001		247	1111 0111	

## Modbus RTU Protocol

1. Default : Baud Rate = 9600 ; Word Length = 8 ; Parity = none ; Stop Bits = 1
2. XXXX is the checksum for CRC-16/MODBUS.

## Data Reading Type

	Device ID	Function	Address (High byte)	Address (Low byte)	Data Length (High byte)	Data Length (Low byte)	Checksum (High byte)	Checksum (Low byte)
CO2	By setting	0x03	0x00	0x00	0x00	0x01	0xXX	0xXX
Temp	By setting	0x03	0x00	0x01	0x00	0x01	0xXX	0xXX
Humi	By setting	0x03	0x00	0x02	0x00	0x01	0xXX	0xXX
CO2 & Temperature & Humidity	By setting	0x03	0x00	0x00	0x00	0x03	0xXX	0xXX

## Responding Data Type

	Device ID	Function	Data byte	CO2(PPM)		TEMP °C		Humi %RH		Checksum (High byte)	Checksum (Low byte)
				Data (High byte)	Data (Low byte)	Data (High byte)	Data (Low byte)	Data (High byte)	Data (Low byte)		
CO2	By setting	0x03	0x02	0x02	0xDC					0XX	0XX
Temp	By setting	0x03	0x02			0x09	0x34			0XX	0XX
Humi	By setting	0x03	0x02					0x13	0x0B	0XX	0XX
CO2 & Temperature & Humidity	By setting	0x03	0x06	0x02	0xDC	0x09	0x34	0x13	0x0B	0XX	0XX

### \*Remark :

1. The CO2 data obtained is hexadecimal. For example, convert 0x02DC (hexadecimal) to decimal, we will get 732ppm as CO2 value.
2. The temperature data obtained is hexadecimal. For example, convert 0x0934 (hexadecimal) to decimal and divided by 100, we will get 23.56°C as temperature value.
3. The humidity data obtained is hexadecimal. For example, convert 0x130B (hexadecimal) to decimal and divided by 100, we will get 48.75% as humidity value.

## Calibration

To calibrate 732ppm to 662ppm, convert the calibration value to 0xFFBA (hexadecimal). The correction is  $(662-732) = -70$ ppm.

Device ID	Function	Address (High byte)	Address (Low byte)	Data (High byte)	Data (Low byte)	Checksum (High byte)	Checksum (Low byte)
By Setting	0x06	0x00	0x03	0xFF	0xBA	0XX	0XX

To calibrate 23.56°C to 20.56°C, convert the calibration value to 0xFED4. The correction is  $(20.56-23.56) * 100 = -300$

Device ID	Function	Address (High byte)	Address (Low byte)	Data (High byte)	Data (Low byte)	Checksum (High byte)	Checksum (Low byte)
By Setting	0x06	0x00	0x04	0xFE	0xD4	0XX	0XX

To calibrate 48.75%RH to 45.75%RH, convert the calibration value to 0xFED4. The correction is  $(45.75-48.75) * 100 = -300$

Device ID	Function	Address (High byte)	Address (Low byte)	Data (High byte)	Data (Low byte)	Checksum (High byte)	Checksum (Low byte)
By Setting	0x06	0x00	0x05	0xFE	0xD4	0XX	0XX

### \*Remark :

The calibration range of CO2 is  $\pm 70$ ppm and is  $\pm 500$  (°C / %RH) for temperature and humidity.

### Baud rate and connection setting

To change baud rate from 9600 to 19200, and set the connection setting as 8/E/2, the command would be “0x1011”.

Settings	Device ID	Function	Address (High byte)	Address (Low byte)	Data (High byte)	Data (Low byte)	Checksum
9600	By setting	0x06	0x00	0x06	0x00	-	XXXX
19200	By setting	0x06	0x00	0x06	0x10	-	XXXX
38400	By setting	0x06	0x00	0x06	0x20	-	XXXX
57600	By setting	0x06	0x00	0x06	0x30	-	XXXX
115200	By setting	0x06	0x00	0x06	0x40	-	XXXX
8/N/1	By setting	0x06	0x00	0x06	-	0x00	XXXX
8/N/2	By setting	0x06	0x00	0x06	-	0x01	XXXX
8/E/1	By setting	0x06	0x00	0x06	-	0x10	XXXX
8/E/2	By setting	0x06	0x00	0x06	-	0x11	XXXX
8/O/1	By setting	0x06	0x00	0x06	-	0x20	XXXX
8/O/2	By setting	0x06	0x00	0x06	-	0x21	XXXX

\* Remark: The connection setting format is Word length/Parity/Stop bits; Parity: N = None, E = Even, O = Odd

### Reset to default settings

To reset all the settings to default, please press and hold SW2 for 5 sec.

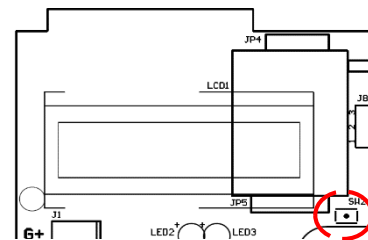

**Dimensions**

**Wall mount Type**

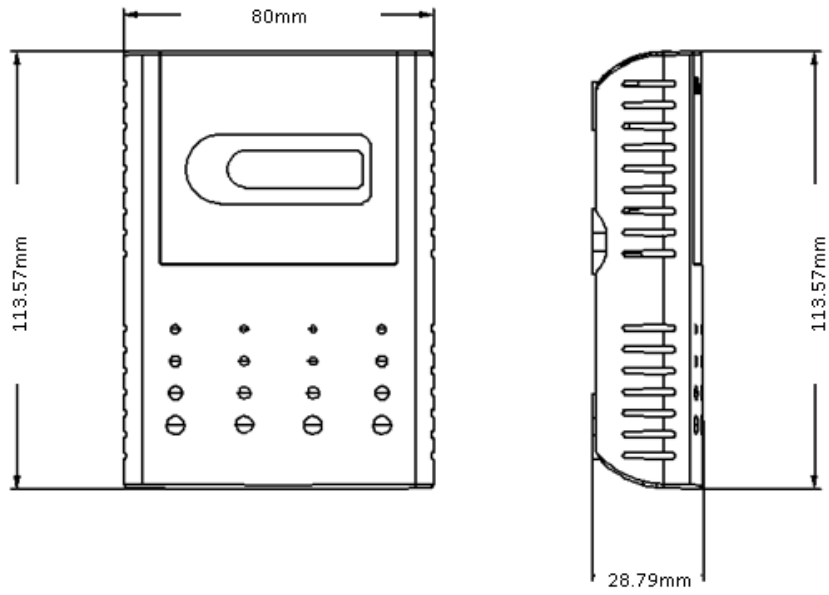

**Duct mount Type**

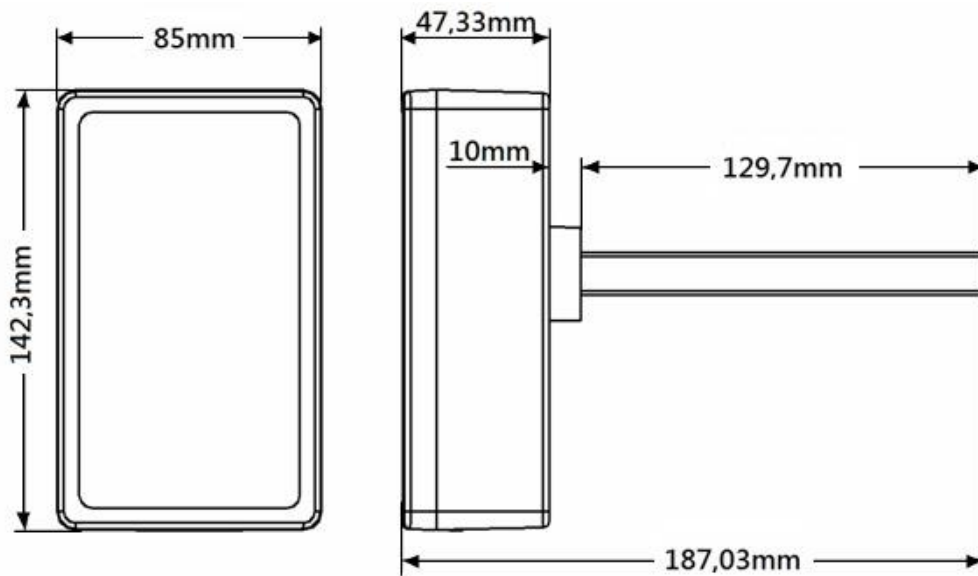

## Installation

1. Please check if the transmitter, accessory pack and instruction manual are included in the package.
2. Please decide right position for installation.

### Wall mount type

- Press tenon on bottom of the housing with a screw driver to remove the upper cover.  
(Please refer to the Figure 2 to Figure 4)



【Figure 2】

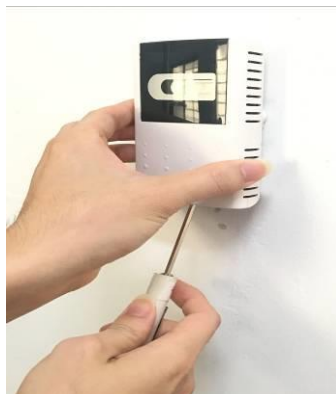

【Figure 3】



【Figure 4】

### Duct mount type

- Press tenon on the bottom of the housing with a screw driver to remove the upper cover.  
(Please refer to the Figure 5)

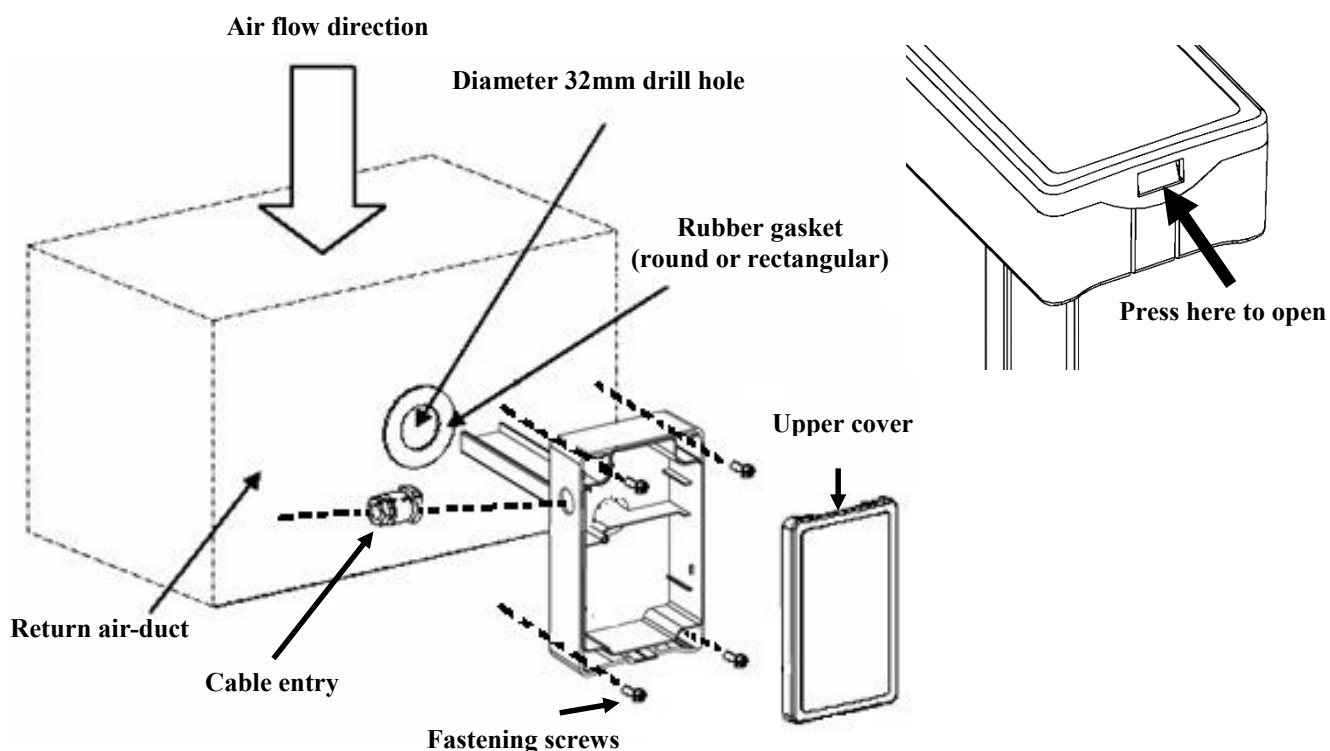

【Figure 5】

**Notice for installation**

1. Please install the transmitter around 1~2m above floor level for better detection.
2. Please avoid the location near fans, exhaust fan, air conditioner vent or elevator entrance.
3. Please avoid the waterish area or direct sunlight.
4. Do not install the transmitter on an unstable or shaking surface.
5. Do not install the transmitter in areas with rapid temperature changes or with extreme ambient conditions.
6. Please avoid heat source or the device exhausting gas.

**Trouble shooting**

<b>Problem</b>	<b>Possible cause</b>	<b>Recommended solution</b>
No response after wiring power supply.	<ol style="list-style-type: none"> <li>1. Insufficient power supply.</li> <li>2. The power wiring is disconnected.</li> </ol>	<ol style="list-style-type: none"> <li>1. Please make sure the power supply should be more than 1.6W.</li> <li>2. Check power wiring.</li> </ol>
The reading is lower than actual level.	<ol style="list-style-type: none"> <li>1. Sensing element is aging.</li> <li>2. Zero point drift.</li> </ol>	Please contact the manufacturer
RS485 connection fails.	<ol style="list-style-type: none"> <li>1. Incorrect device ID setting or incorrect connection settings.</li> <li>2. RS485 wiring is disconnected.</li> </ol>	<ol style="list-style-type: none"> <li>1. Please verify the device ID and connection settings.</li> <li>2. Check RS485 wiring.</li> <li>3. Reset to default settings.</li> </ol>
High loss rate of packet for RS485	<ol style="list-style-type: none"> <li>1. Signal interference.</li> <li>2. RS485 wiring is disconnected.</li> </ol>	<ol style="list-style-type: none"> <li>1. It is recommended to use 2 pair twisted shielded cable.</li> <li>2. Check RS485 wiring.</li> </ol>