

AVC-310 CO2 (RS485 Output) Transmitter Instruction Manual

Thanks for choosing our product! Please read carefully and follow this instruction before using!

Introductions

AVC-310 series is designed for measuring the ambient carbon dioxide concentration. It can provide signal output for environmental monitoring or control. Utilizing NDIR sensing element ensures its accuracy of measurement. Two different types for standard (0~2000ppm) and higher level (0~9999ppm) measurement range. The standard type is for building climate control, greenhouse, library, offices, shopping mall; and the high level type can be used in chemical gas factory, wine cellar, brewery and etc.

Wiring

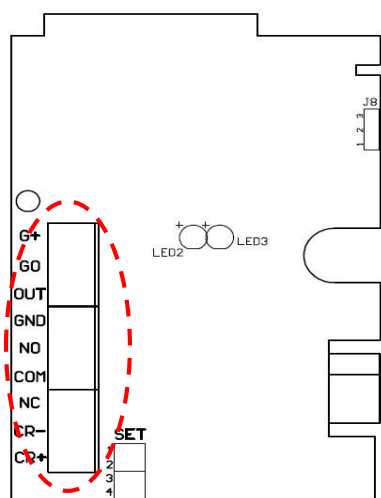

1.	G+	DC 12 ~ 36V AC 24V (50/60Hz)
2.	G0	System GND
3.	OUT	N/A
4.	GND	N/A
5.	N.O	Normally opened
6.	COM	Com
7.	N.C	Normally closed
8.	CR-	RS-485(-)
9.	CR+	RS-485(+)

Connection

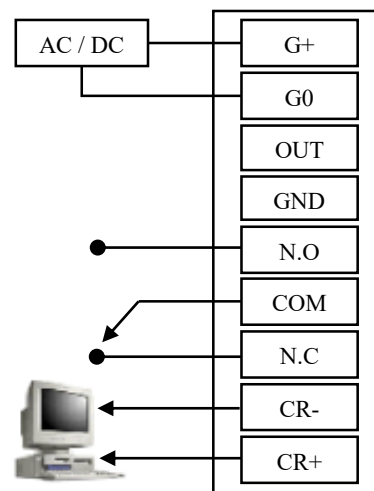

【Figure 1】

Notice: Please remove power from the unit before wiring, in order to avoid any damage or hazard.

Relay output (CO2 set point alarm)

Set CO2 alarm relay output with SET2.

Relay Contact setting :

Relay Output (Hysteresis is 100ppm)		SET 2
Standard Type	High Level Type	
800 ppm	8000 ppm	
1000 ppm (Default)	9999 ppm (Default)	

* When the CO2 concentration reaches the alarm setting point, LED indicator will be switched on.

* The standard type is for general indoor use. For any special application, such as industrial or agriculture, please contact us.



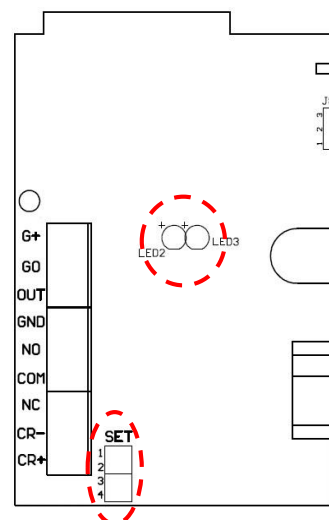



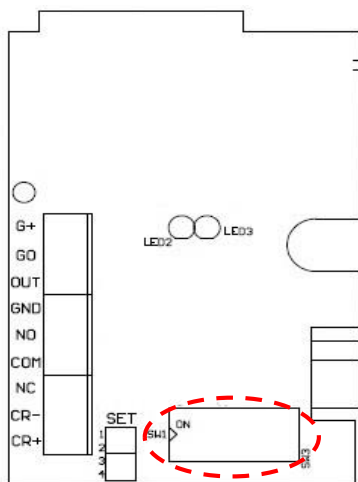

* Please do not use the AVC-310 series in high humidity environment.



Device ID Setting

ID with dip switch : ON  : 1, OFF  : 0



Device ID (ON : 1, OFF : 0)							
1	0000 0001		127	0111 1111			
2	0000 0010		128	1000 0000			
⋮		⋮	⋮		⋮		
64	0100 0000		246	1111 0110			
65	0100 0001		247	1111 0111			

Modbus RTU Protocol

- Baud Rate = 9600 (Default) ; Word Length = 8 ; Parity = none ; Stop Bits = 1
- Checksum is the error detection codes for CRC-16/MODBUS.

Data Reading Type

Device ID	Function	Address (High byte)	Address (Low byte)	Data Length (High byte)	Data Length (Low byte)	Checksum (High byte)	Checksum (Low byte)
By setting	0x03	0x00	0x00	0x00	0x01	0xXX	0xXX

Responding Data Type

Device ID	Function	Data byte	Data (High byte)	Data (Low byte)	Checksum (High byte)	Checksum (Low byte)
By setting	0x03	0x02	0x02	0xDC	0xXX	0xXX

***Remark** : The CO₂ data obtained is hexadecimal. For example, convert 0x02DC (hexadecimal) to decimal, we will get 732ppm.

Calibration

To calibrate 732ppm to 662ppm, convert the calibration value to 0xFFBA (hexadecimal).

The correction is as below: (662-732) = -70ppm.

Device ID	Function	Address (High byte)	Address (Low byte)	Data (High byte)	Data (Low byte)	Checksum (High byte)	Checksum (Low byte)
By setting	0x06	0x00	0x01	0xFF	0xBA	0xXX	0xXX

To reset to default value, please set 0x0000 (hexadecimal).

Device ID	Function	Address (High byte)	Address (Low byte)	Data (High byte)	Data (Low byte)	Checksum (High byte)	Checksum (Low byte)
By setting	0x06	0x00	0x01	0x00	0x00	0xXX	0xXX

* **Remark** : The calibration range of CO₂ is ±70ppm.

Baud rate and connection setting

To change baud rate from 9600 to 19200, and set the connection setting as 8/E/2, the command would be “0x1011”.

Settings	Device ID	Function	Address (High byte)	Address (Low byte)	Data (High byte)	Data (Low byte)	Checksum
9600	By setting	0x06	0x00	0x02	0x00	-	XXXX
19200	By setting	0x06	0x00	0x02	0x10	-	XXXX
38400	By setting	0x06	0x00	0x02	0x20	-	XXXX
57600	By setting	0x06	0x00	0x02	0x30	-	XXXX
115200	By setting	0x06	0x00	0x02	0x40	-	XXXX
8/N/1	By setting	0x06	0x00	0x02	-	0x00	XXXX
8/N/2	By setting	0x06	0x00	0x02	-	0x01	XXXX
8/E/1	By setting	0x06	0x00	0x02	-	0x10	XXXX
8/E/2	By setting	0x06	0x00	0x02	-	0x11	XXXX
8/O/1	By setting	0x06	0x00	0x02	-	0x20	XXXX
8/O/2	By setting	0x06	0x00	0x02	-	0x21	XXXX

* Remark: The connection setting format is Word length/Parity/Stop bits; Parity: N = None, E = Even, O = Odd

Reset to default settings

To reset all the settings to default, please press and hold SW2 for 5 sec.

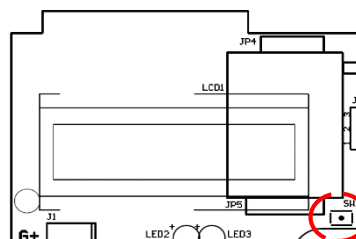

Dimensions

Wall mount Type

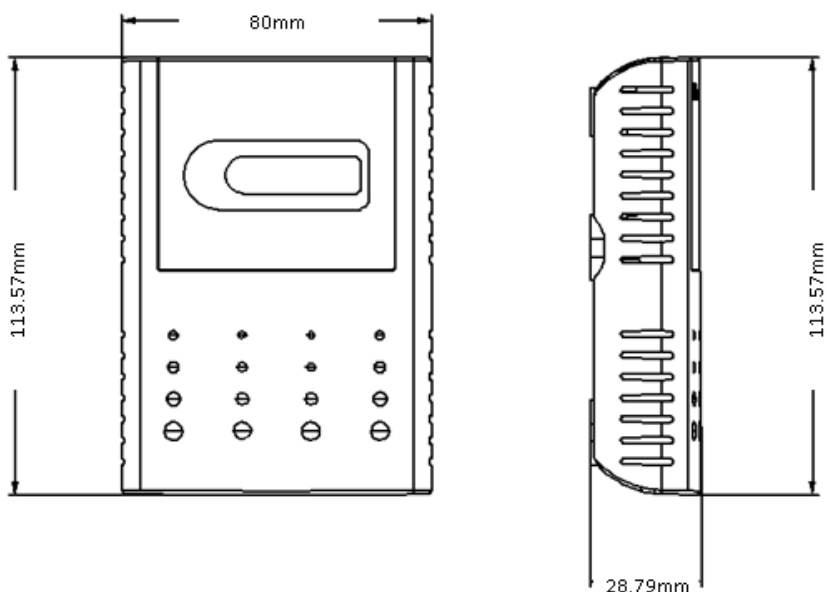

Duct mount Type

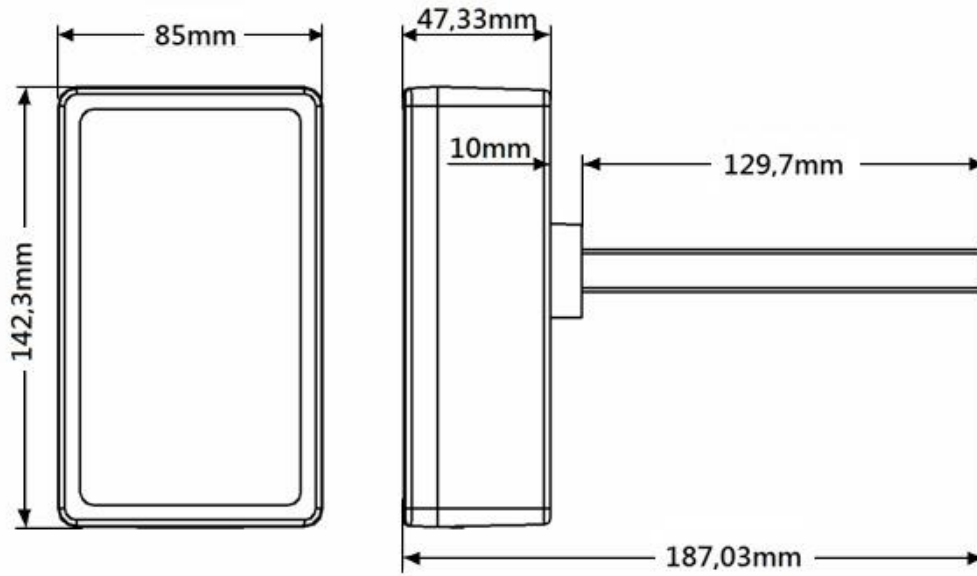

Installation

1. Please check if the transmitter, accessory pack and instruction manual are included in the package.
2. Please decide right position for installation.

Wall mount type

- Press tenon on bottom of the housing with a screw driver to remove the upper cover.
(Please refer to the Figure 2 to Figure 4)



【Figure 2】

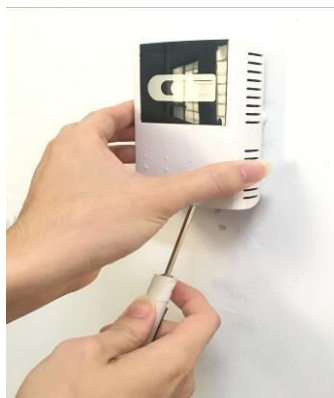

【Figure 3】



【Figure 4】

Duct mount type

- Press tenon on the bottom of the housing with a screw driver to remove the upper cover. (Please refer to the Figure 5)

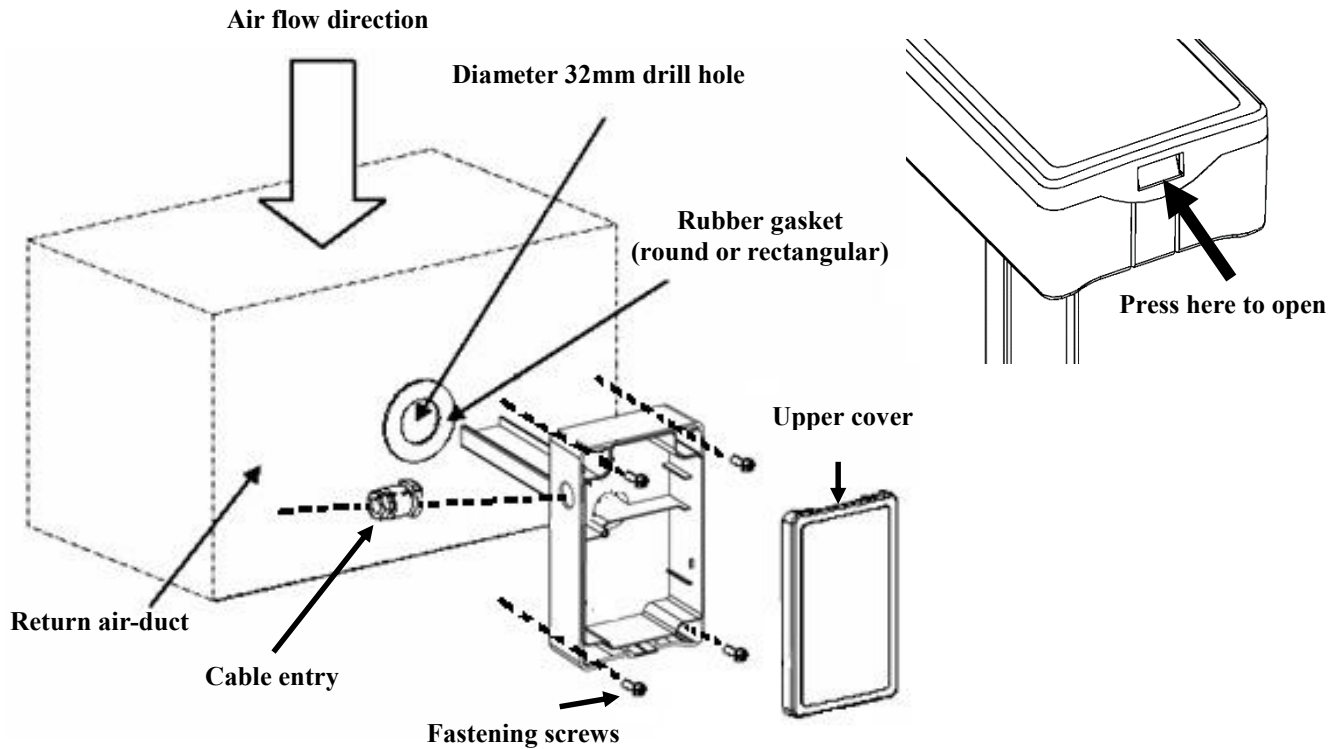

【Figure 5】

Notice for installation

1. Please install the transmitter around 1~2m above floor level for better detection.
2. Please avoid the location near fans, exhaust fan, air conditioner vent or elevator entrance.
3. Please avoid the waterish area or direct sunlight.
4. Do not install the transmitter on an unstable or shaking surface.
5. Do not install the transmitter in areas with rapid temperature changes or with extreme ambient conditions.
6. Please avoid heat source or the device exhausting gas.

Trouble shooting

Problem	Possible cause	Recommended solution
No response after wiring power supply.	Insufficient power supply. The power wiring is disconnected.	Please make sure the power supply should be more than 1.6W. Check power wiring.
The reading is lower than actual level.	Sensing element is aging. Zero point drift.	Please contact the manufacturer
RS485 connection fails.	Incorrect device ID setting or incorrect connection settings. RS485 wiring is disconnected.	Please verify the device ID and connection settings. Check RS485 wiring. Reset to default settings.
High loss rate of packet for RS485	Signal interference. RS485 wiring is disconnected.	It is recommended to use 2 pair twisted shielded cable. Check RS485 wiring.