

Differential Pressure Transmitter (Current output) Instruction Manual

Thanks for choosing our product! Please read carefully and follow this instruction before using!

Introductions

The ADP series uses CMOSens technology sensor, which measures the pressure of air and non-aggressive gases with superb accuracy and no offset drift. It can measure over- or under-pressure in air ducts in relation to ambient pressure as well as to monitor filters and to control fans and acquire pressure differentials between different rooms. It can be widely applied to air-conditioning and ventilation systems, building automation, environmental protection, fan and ventilation control, valve and shutter control, filter and fan monitoring.

Wiring



Figure 1

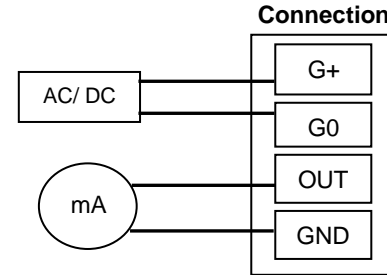



1.	G+	DC 15 ~ 36V AC 24V (50/60Hz)
2.	G0	System GND
3.	OUT	4~20mA
4.	GND	Signal GND

DP measuring range settings

Jumper setting

Define differential pressure measuring range with the jumper in J6.

1 : (short-circuit)  , 0 : (open-circuit) 

Differential Pressure measuring range setting:

- ..Set J6 (1,2) as "0 1" → Measuring range is set as zero ~ positive differential pressure.
- Set J6 (1,2) as "1 0" → Measuring range is set as zero ~ negative differential pressure.
- .. Set J6 (1,2) as "0 0" → Measuring range is set as negative pressure ~ positive differential pressure.

Define differential pressure measuring range upon different models.

ADP-025

Range settings	J6(1)	J6(2)
0 ~ 25 Pa (Default)	0	1
0 ~ -25 Pa	1	0
-25 ~ +25 Pa	0	0

ADP-125

Range settings	J6(1)	J6(2)
0 ~ 125 Pa (Default)	0	1
0 ~ -125 Pa	1	0
-125 ~ +125 Pa	0	0

ADP-500

Range settings	J6(1)	J6(2)
0 ~ 500 Pa (Default)	0	1
0 ~ -500 Pa	1	0
-500 ~ +500 Pa	0	0

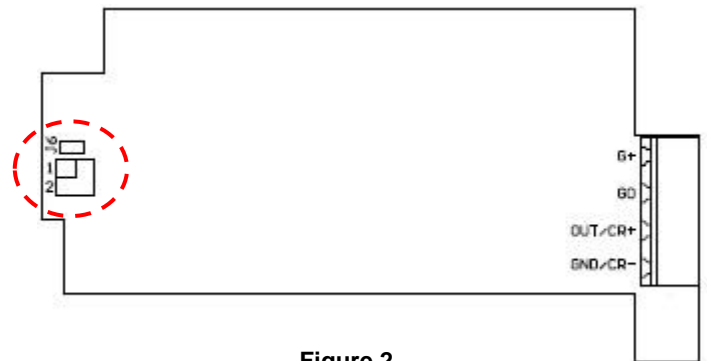
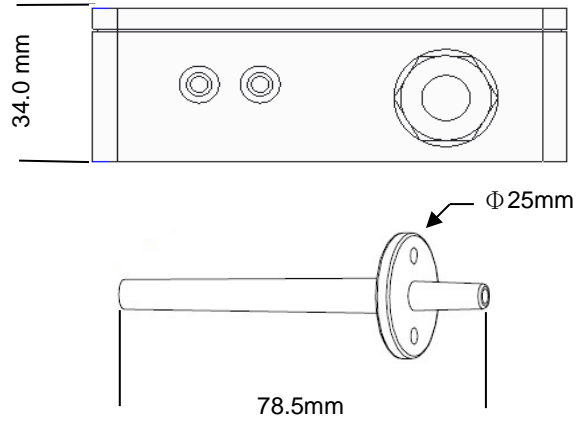
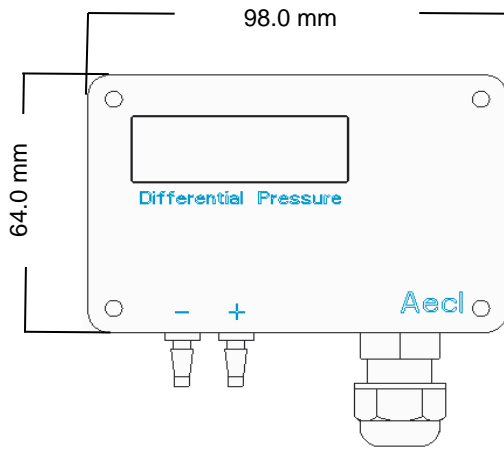

Figure 2

Dimensions



Installation

1. Loosen the four screws to remove the top cover.

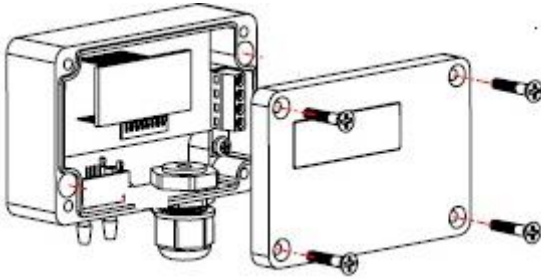

2. Fix the base unit with two self-tapping screws on the wall. For concrete wall, please apply plastic anchor.

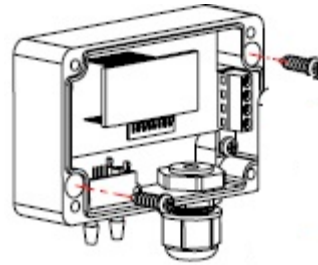

3. Drill two holes with diameter of 7mm on duct and another two holes of 2.2mm to fix connecting pipe with self-tapping screws.

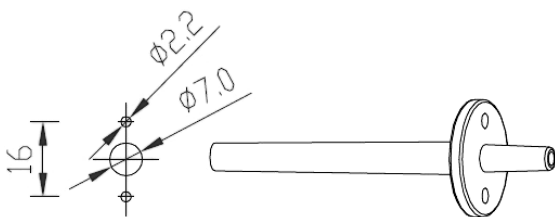

4. Join the connecting pipe and the connector on differential pressure transmitter with plastic connecting tube. Please refer Figure 1 for wiring. And recover the top cover and fix it with four screws.

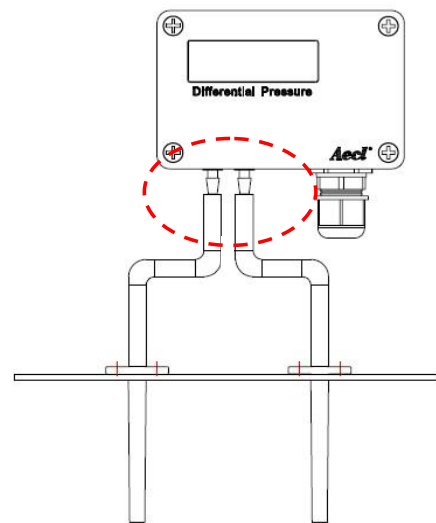

Remark :

1. Please install the differential pressure transmitter on a flat surface and well-fixed.
2. Please install the connecting pipe vertically to the differential pressure transmitter.
3. Notice: Please remove power from the unit before wiring, in order to avoid any damage or hazard.