

JACE-8000 (12977) Controller

Mounting and Wiring Guide

Figure 1 JACE-8000 controller (with one option module).

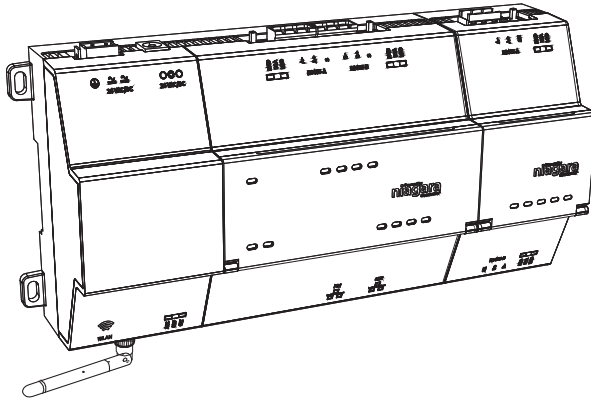

This document covers mounting and wiring of the following products.

Model	Description
12977 (JACE-8000)	<p>DIN rail-mount, 24Vac/dc powered, Niagara 4® area controller, using an ARM® Cortex™-A8 1Ghz processor, 1GB DDR3 SDRAM, 2Mb (megabit) Serial FRAM, and up to 4GB microSD Flash memory. Two 10/100Mbit Ethernet ports, two electrically isolated RS485 ports and an integral 802.11a/b/g/n WiFi® adapter are standard. The integral power supply requires either 24Vac 50/60Hz, 24Vdc, or a wall-mount AC power adapter. Internal battery backup is not required or available.</p> <p>DIN rail-mount option modules directly attach for additional communications ports, including types for LonWorks® (FTT-10), RS232 (DB-9), and dual RS485. The controller supports up to four (4) option modules. See “Option module and capacity considerations”.</p> <p>Remote I/O expansion modules (T-IO-16-485) are supported by RS485 connection to the controller. See “RS485 wiring,” page 5.</p>
WPM-8000	<p>Wall-mount, Class 2 universal AC power adapter supplying 24Vdc to a cable with a barrel-connector plug.</p>

See *JACE-8000 Niagara 4 Install and Startup Guide* for Niagara 4 software installation and configuration details. Also see “[Related documentation](#),” page 8.

Included with the controller

- JACE-8000 (12977) controller.
- MicroSD card in plastic case. See “[Preparation](#),” page 2.
- Coax-mount, dual 2.4/5.8GHz antenna for WiFi®, two 3-position RS485 connector plugs, one 2-position power connector plug, and a grounding wire.
- *JACE-8000 Controller (12977) Quick Start Guide*

Material and tools required

- One of the following:
 - UL listed, Class 2, 24Vac transformer, rated at minimum of 24Va. A dedicated transformer is required (cannot power additional equipment), *or*
 - UL listed Class 2 or LPS 24Vdc power supply, capable of supplying at least 1A (24W), *or*
 - WPM-8000 wall-mount AC power adapter with barrel connector plug.
- DIN rail, type NS35/7.5 (35mm x 7.5mm) and DIN rail end-clips (stop clips), recommended for any installation with option modules. Controller is also panel-mountable.
- Suitable tools, fasteners, and accessories for mounting.

Option module and capacity considerations

The controller supports a maximum total of four option (expansion) modules in certain combinations. If you use two RS485 option modules, you are limited to one additional “non-RS485” module (LON or 232) for a total of three. The following figure shows some example combinations.

Figure 2 Valid module combinations

		232 or LON	232 or LON	EXPANSION 4
	232 or LON	232 or LON	232 or LON	EXPANSION 3
485 485	485 485	232 or LON	232 or LON	EXPANSION 2
485 485	485 485	485 485	232 or LON	EXPANSION 1
Baseboard:			485 485	

Table 1 Maximum option modules supported by protocol

Expansion Module	Max Components
NPB-8000-LON	4
NPB-8000-232	4
NPB-8000-2X-485	2

Static discharge precautions

Separate maximum limits may be defined in the controller’s license, such as total number of networks, devices, and integration points (capacity licensing).

Table 2 Maximum wired field bus integrations.

Protocol	Max	Description, Option Module
RS485	7	Two via onboard RS485, four via two Dual RS485 option modules (2 ports each), plus one via LON or RS232.
Lonworks FTT-10	4	Four LON option modules (1 port each module)
RS232	4	Four RS232 option modules (1 port each module)

Note that maximums in Table 2 on page 2 do not reflect combinations of wired field bus integrations. Two examples:

- Two RS485 (via onboard RS485), two Lonworks FTT-10 (2 LON modules), two RS232 (2 RS232 modules). Maximum number of option modules (4) are installed.
- Four RS485 (2 via onboard RS485, 2 from a single Dual RS485 module), two Lonworks FTT-10 (2 LON modules). In this case, three (3) option modules are installed.

Future option module types may have additional maximum limits, within the “4 total” option per controller limit.

Safety precautions

- Warning**
- **Disconnect power before installation or servicing to prevent electrical shock or equipment damage.**
 - **Use copper conductors only. Make all connections in accordance with local, national, and regional electrical codes.**
 - **To reduce the risk of fire or electrical shock, install in a controlled environment relatively free of contaminants.**
 - **This device is only intended for use as a monitoring and control device. To prevent data loss or equipment damage, do not use it for any other purpose.**
 - **To comply with FCC and Industry Canada RF exposure limits for general population / uncontrolled exposure, the antenna(s) used for this transmitter must be installed to provide a separation distance of at least 20 cm from all persons and must not be co-located or operating in conjunction with any other antenna or transmitter.**

General precautions

Caution Remove all power to controller before attaching (plug in) or detaching (unplug) any option module, to prevent possible equipment damage.

Caution Removal of the controller’s cover is not required. No configurable or user-serviceable items (such as jumpers or a battery) require cover removal—all items are accessible as switches and connectors on the unit’s top, bottom, and side, or behind the unit’s front access door or microSD card shutter.

Static discharge precautions

The microprocessors and associated circuitry within the controller are sensitive to static discharge.

- Caution**
- Work in a static-free area.
 - Discharge any static electricity you may have accumulated. Discharge static electricity by touching a known, securely grounded object.

Preparation

Before mounting a new controller, you must insert the included microSD flash memory card. Note the card has the unique Niagara identity (host ID) for the unit, set at the factory.

Caution Disconnect all power to the controller and use static discharge precautions before removing or inserting the microSD card. Otherwise, equipment damage is likely to occur.

After commissioning the controller, the card also holds the QNX operating system, Java software, installed Niagara 4 software, licenses, certificates, and file space of any installed station.

Figure 3 MicroSD card location in controller.

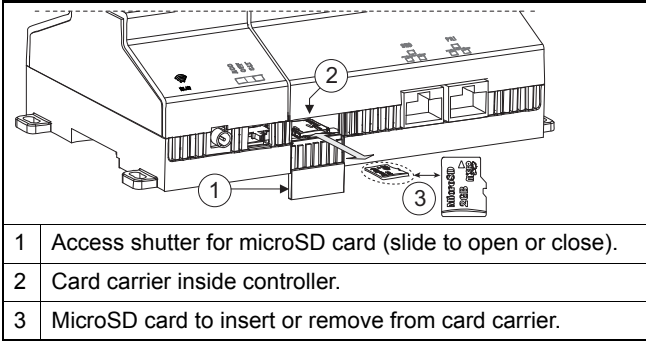

Typically, the microSD card never needs removal. However in the case where a controller has been electrically damaged or found faulty, you can remove the card and install it in another like unit, so it can become a functional replacement.

Inserting or removing the MicroSD card

Prerequisite: **All power** to the controller must be **removed** (see previous [Caution](#)). If the unit is currently running, see “Initiating a controller shutdown,” page 8.

Note the controller must also be *unmounted* from any DIN rail or screw tab mounting, as accessing the card uses space behind the mounting base. See [Figure 3](#) on page 2.

1. Carefully slide the plastic microSD card shutter open.
The shutter should remain captive in the base, revealing the microSD card socket.
2. To *insert* the microSD card, slide it into card carrier, label side up, until the spring catch engages.
If properly inserted, the card is behind the shutter track.
3. To *remove* the microSD card, push it in, until the spring release pushes it partially out of the card carrier. Grasp the card, pull it completely out of the unit and store it in a static free protective case.
4. Carefully slide the card shutter back over the card carrier opening, until it clicks in place. When properly closed, the shutter should not protrude behind the mounting base.

NOTE: Data on the microSD card is encrypted. If you swap in a card from a previously configured unit, you must change the JACE-8000 system passphrase on the platform to match the passphrase on the new microSD card. See *JACE-8000 Niagara 4 Install and Startup Guide* for details.

Mounting

Mount the controller in a location that allows clearance for wiring, servicing, and module removal.

Environmental requirements

NOTE: This product is for **indoor use only**, altitude to 2,000m (6,562 ft.).

Ambient conditions must be within the range of:

- Operating Temperature: -20°C to 60°C (-4°F to 140°F).
Storage Temperature: -40°C to 85°C (-40°F to 185°F).
- Relative humidity: 5% to 95% non-condensing.
Pollution Degree 3
- Supply (mains) voltage requirements are as follows:
 - Allowable voltage fluctuation +/- 10%,
- For a unit mounted inside an enclosure, ensure that the enclosure is designed to keep the unit within its required operating temperature range (considering a 24-watt dissipation by the controller). This is important if the controller is mounted inside an enclosure with other heat-producing equipment.
- Do not mount the unit:
 - in an area with excessive moisture, corrosive fumes, or explosive vapors.
 - where vibration or shock is likely to occur.
 - in a location subject to electrical noise, such as in the proximity of large electrical contactors, electrical machinery, welding equipment, and so on.

Physical mounting

The following applies about physically mounting the unit.

- Horizontal mounting (as shown) is **strongly recommended**, to achieve maximum heat dissipation and meet the operating temperature upper limit. Any other mounting orientation reduces this upper limit.
- Mounting on a 35mm wide DIN rail is recommended. The controller’s unit base has a molded DIN rail slot and locking clip, as do option modules. DIN rail mounting ensures alignment of the connectors between all devices.
- Up to four (4) option modules are supported. See “[Option module and capacity considerations](#),” page 1.
- Dimensions of a unit with option modules are shown in

Figure 4 Mounting dimensions of controller and option modules.

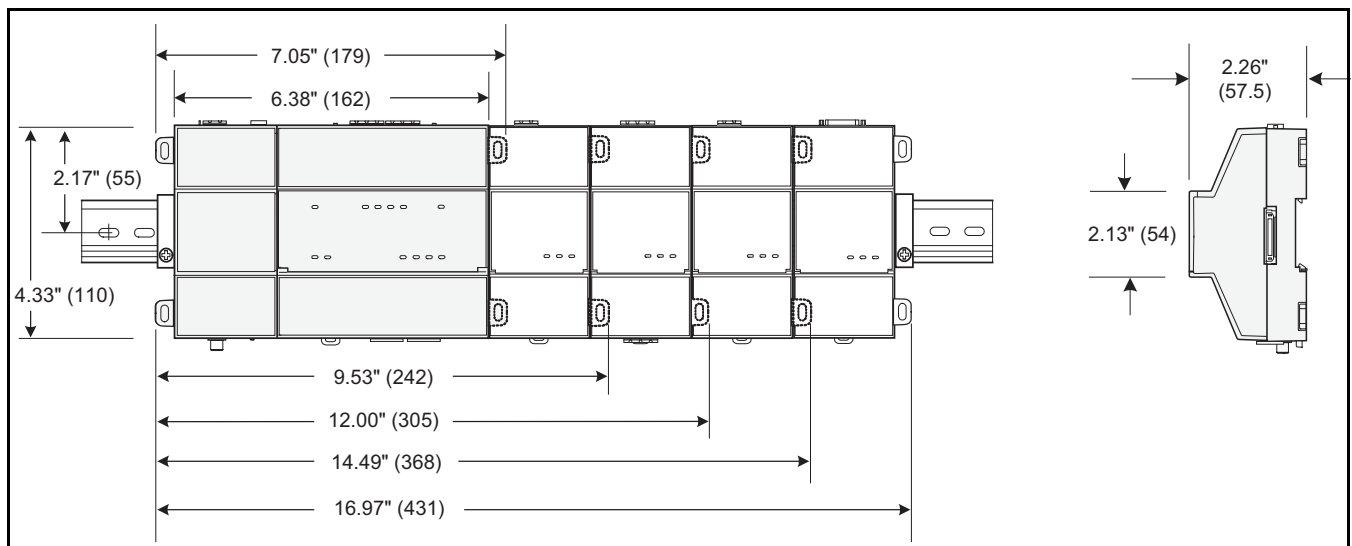

Mounting on DIN rail

Prerequisite: The 35mm DIN rail should be securely mounted, with at least two screws near the rail ends. The microSD card must be installed in the controller. See “Preparation,” page 2.

1. Pull the controller’s locking clip down.

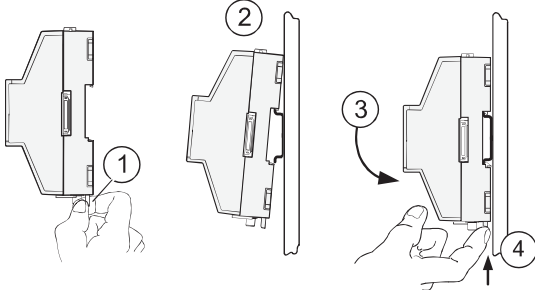

2. Tilt the controller to hook over the DIN rail.
3. Push down and in on the unit, fastening to the rail.
4. Push the locking clip up to secure.
5. Mount any option module onto the DIN rail in the same way.

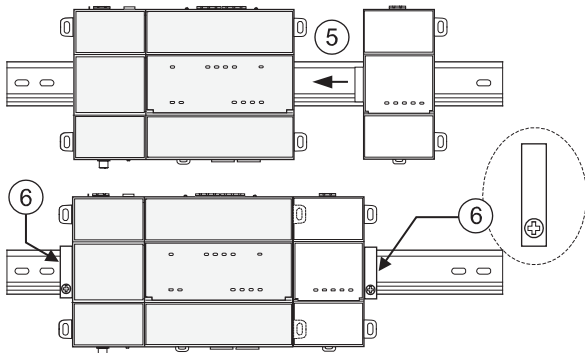

Slide the module firmly into the controller’s connector to seat. Repeat for other modules as needed (4 maximum).

6. Carefully secure both ends of the final assembly with DIN rail end-clips provided by the DIN rail vendor.

NOTE: To remove a unit from the DIN rail, pull down its locking clip. Then swing the bottom out and lift the unit away from the DIN rail.

Wiring

Earth ground and power

Earth grounding provides protection from electrostatic discharge or other forms of EMI.

Figure 5 Earth ground and power options.

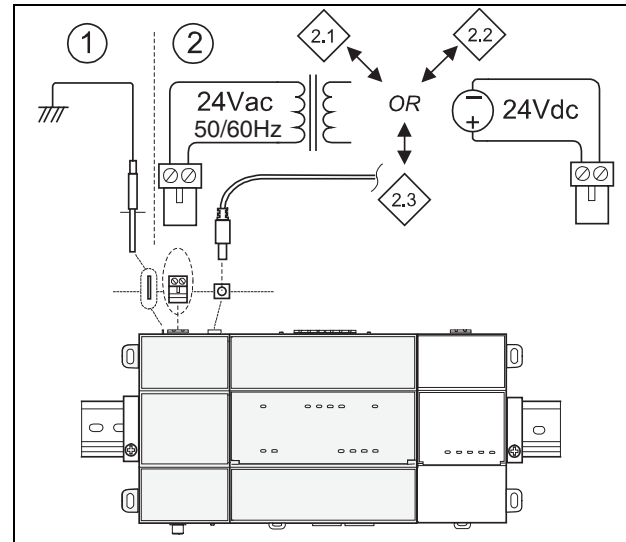

NOTES: Depending on power source used (see Figure 5):

- 2.1 (AC): Dedicated 24V transformer required, with neither side of the transformer secondary tied to ground.
- 2.2 (DC): Polarity is unimportant (uses onboard diode bridge), with neither leg tied to ground.
- 2.3 (Wall-mount AC adapter, WPM-8000) *instead of* wiring 24V to 2-position connector.

Wiring earth ground and power



Warning Before making power terminations, de-energize the 24V power source. Do not restore power until completing all other mounting and wiring. See “Power up and initial checkout” on page 6.

Prerequisite: A nearby earth grounding point.

1. Install the included earth ground wire to the controller’s earth ground spade lug, and terminate the other end to a nearby earth ground.
2. Unplug the controller’s 2-position power connector plug and terminate the 24V supply source (AC or DC) to the connector. Leave connector unplugged for now.

Communications wiring

Ports for field communications are shown in [Figure 6](#).

Figure 6 Communications ports on controller.

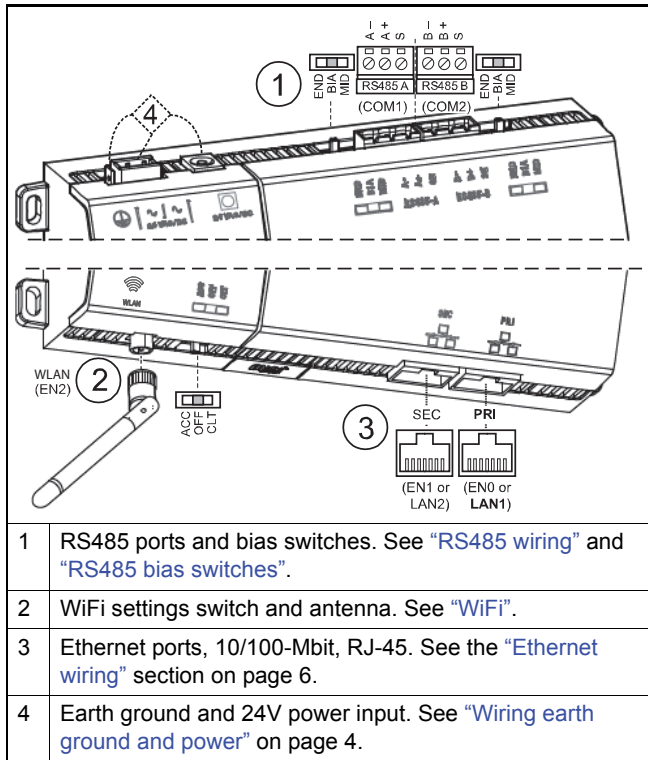

WiFi

An integral WiFi adapter provides wireless connectivity using the IEEE 802.11a/b/g/n standard, and provides an RP-SMA antenna connector.

The WiFi configuration switch sets operation as follows:

- **OFF** - (Default, middle) WiFi adapter is disabled.
- **ACC** - Controller provides operation as a WiFi access point for up to 20 clients.
- **CLT** - Controller operates as a client to an existing 802.11a/b/g/n router or access point.

To use, either attach the included tilt-and-swivel 2.4GHz antenna directly (as shown in [Figure 6](#)), or else use an optional coax cable extension kit (CBL-WIFI-EXT) to locate the antenna up to 2m (6.6ft) away. An associated LED remains lit whenever WiFi is enabled. See “[Status LEDs](#),” page 6.

Refer to the *JACE-8000 WiFi Guide* for details on WiFi configuration and factory-default settings.

RS485 wiring

On the controller’s top side, two RS485 ports operate as COM1 and COM2. Each port is capable of up to 115,200 baud, and uses a 3-position, screw terminal connector.

Figure 7 RS485 wiring example.

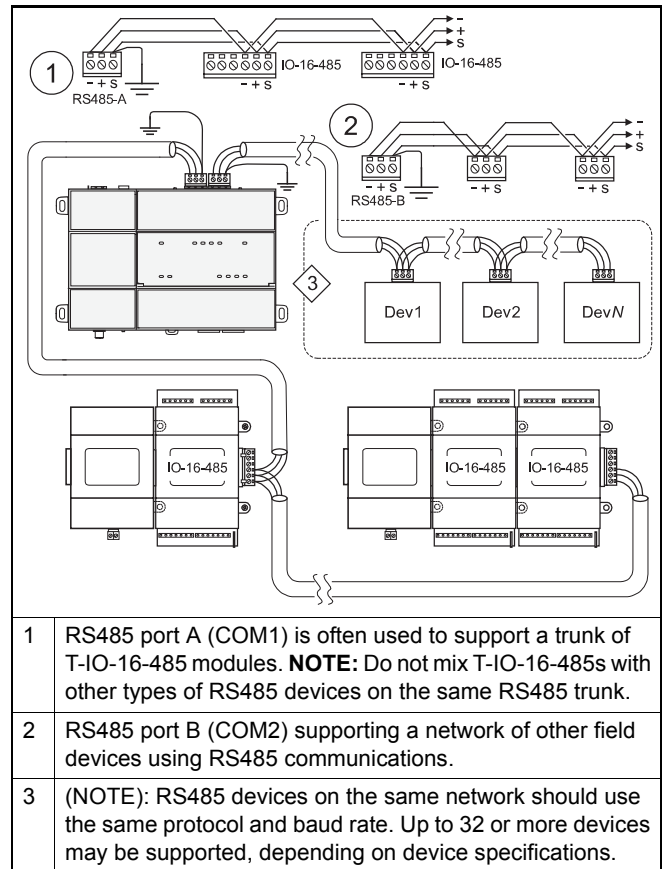

Use shielded, twisted-pair, 18-22 AWG cabling to wire in a continuous multidrop fashion to other RS485 devices: “minus to minus”, “plus to plus,” and “shield to shield.”

Connect the shield wire to earth ground at one end only, for example at the controller. [Figure 7](#) shows example wiring.

RS485 bias switches — Each RS485 port has an adjacent 3-position biasing switch, with these settings:

- **BIA** - (Default, middle) RS485 biasing and termination: 2.7K Ohm bias resistors with no termination resistor
- **END** - RS485 biasing and a termination: 562 Ohm bias resistors and 150 Ohm termination resistor
- **MID** - RS485 biasing or termination: 47.5K bias resistors with no termination resistor

Often, adding RS-485 biasing can improve communications by eliminating indeterminate idle states.

- **BIA** - (Default, middle) Often best if the RS485 trunk needs biasing, but when the controller is not installed at the end of the trunk.
- **END** - Often best if the controller is installed at the end of an RS485 trunk of devices that is not already biased.
- **MID** - Often best if the controller is put in the middle of an already-biased RS485 trunk.

If desired, you can change the position of an RS485 port's bias switch while the controller is running.

Each RS485 port has two LEDs. See "RS485 LEDs," page 6.

Ethernet wiring

Two RJ-45 10/100-Mbit Ethernet connectors are labeled PRI (LAN1) for *primary*, and SEC (LAN2) for secondary. Use a standard Ethernet patch cable to an Ethernet switch.



Caution The JACE-8000 is not compatible with a Power-Over-Ethernet (POE) network. Connecting the JACE on a network segment which carries power may cause the unit to fail. In that event, you must disconnect it from the POE network segment and power-cycle the unit.

The factory-default IP address for PRI is 192.168.1.140. The subnet mask is 255.255.255.0. By default, the SEC (LAN2) port is disabled.

Refer to the *JACE-8000 Niagara 4 Install and Startup Guide* for details on the software configuration of the Ethernet ports.

NOTE: Often, you only use PRI (LAN1 primary), unless you have a specific application for the other port. For example, isolating a driver's network traffic, using SEC (LAN2). Do not use SEC as the primary port.

If enabling SEC, note that PRI and SEC must be connected to *different IP subnets*. Further, a JACE controller does not provide IP routing or bridging operation between the two Ethernet ports.

Power up and initial checkout

Prerequisite: Ensure power and ground wiring to the controller is ready—see wiring "Earth ground and power" on page 4. See Figure 8 on page 6 for the location of status LEDs.

1. **Apply power.** To do this, do *one* of the following:

- Insert the 2-position 24V power connector plug, or
- Insert the barrel plug of the wall-mount AC adapter (WPM-8000).

2. **Check the STAT (Status) and BEAT (Heartbeat) LEDs.**

When power is applied, after 3-10 sec, the green "STAT" LED illuminates, indicating that the system is OK, with power applied. During bootup, the "BEAT" LED may blink at 1 Hz with a 90%/10% on/off duty cycle, or in some other irregular pattern. When bootup completes, the normal 1 Hz "BEAT" LED flash at 50%/50% on/off duty cycle returns.

If after applying power, the "STAT" LED goes out, or if the "BEAT" LED comes on (steady) and stays lit over 2 minutes, contact Systems Engineering for technical assistance. See the section "Status LEDs" on page 6, especially "BEAT (Heartbeat) LED".

For more details in this mounting and wiring document, see:

- "Status LEDs," page 6
- "USB ports and pushbutton switches," page 8

For further JACE-8000 controller details, see:

- *JACE-8000 Niagara 4 Install and Startup Guide.*
Explains how to commission a new JACE-8000 controller, i.e. how to install Niagara 4 software, configure Niagara platform settings, and install a Niagara station.
- *JACE-8000 USB Backup and Restore Guide*
Explains USB backups and restores for a JACE-8000 controller.
- *Niagara 4 JACE WiFi Operation Guide*
Explains JACE-8000 WiFi configuration and operation.

Status LEDs

The controller provides a number of status LEDs, with all but one visible with the front access door closed. See Figure 8.

Figure 8 LEDs and brief descriptions.

1	WiFi (Green) - Lit whenever WiFi config switch is not Off.
2	RS485 "A" (COM1): Transmit (TX, Yellow) and Receive (RX, Green). See "RS485 LEDs".
3	RS485 "B" (COM2): Transmit (TX) and Receive (RX).
4	STAT (Green) - Remains lit. See "STAT (Status) LED".
5	BEAT (Yellow) - "Heartbeat" LED that blinks at 1Hz during normal operation. See "BEAT (Heartbeat) LED" on page 7.
6	Secondary Ethernet, SEC (LAN2) "Link" (Green) and "Activity" (Yellow).
7	Primary Ethernet SEC (LAN1) "Link" (Green), "Activity" (Yellow). See "PRI, SEC (Ethernet) LEDs" on page 7.
8	(Behind Door) BACKUP - Green, typically Off unless a USB drive is inserted, or a backup, restore, or factory recovery image install is in progress. See "BACKUP LED" on page 7.

RS485 LEDs

RS485 port A (COM1) and RS485 port B (COM2) each have two LEDs reflecting port activity as follows:

- **Yellow** (TX): indicates the controller is transmitting data on the RS485 port.
- **Green** (RX): indicates the controller is receiving data from an RS485 device connected to this port.

These LEDs use a fixed "on time" when a message is detected on the port. If a receive LED is on constantly, this can indicate a wiring problem, such as a shorted wire or reversed wiring.

STAT (Status) LED

The **green** “STAT” LED provides a CPU machine status check, and should remain lit whenever the controller is powered. If the status LED does not light while power is applied, contact System Engineering for technical support.

BEAT (Heartbeat) LED

In normal operation, the **yellow** heartbeat “BEAT” LED blinks at 1 Hz, at 50%/50% on/off duty cycle.

During controller bootup, this LED may blink at 1 Hz with a 90%/10% on/off duty cycle, or in some other irregular pattern. When bootup completes, the platform daemon is started, and the normal 1 Hz flash at 50%/50% on/off duty cycle returns.



Caution The 1Hz, 90%/10% on/off “BEAT” flash at bootup also occurs during other critical operations, such as a firmware upgrade to the controller and/or any attached modules. To be safe, do not remove power from the controller while its “BEAT” LED flashes with a 90%/10% on/off duty cycle. Wait for the normal (50%/50%) flash to return before removing power.

If the “BEAT” LED stays on constantly, does not light, or blinks very fast, contact System Engineering for technical support.

PRI, SEC (Ethernet) LEDs

Two LEDs for each of the two LAN ports indicate as follows.

- **Green** (left-side) “Link” LED operates as follows:
 - Off: No Ethernet link is made.
 - On: Ethernet link is made.
- **Yellow** (right-side) “Activity” LED operates as follows:
 - Off: No Ethernet activity.
 - On: Blinking indicates activity (typical if Link is On).

BACKUP LED

A **green** “BACKUP” LED is behind the front access door, and is visible only if the door is open—see [Figure 9](#) on page 8. Typically, this LED remains Off.

Possible “BACKUP” LED states are:

On solid: USB backup media detected. Occurs when you insert a USB flash drive, to signal a backup is possible.

Alert mode: 100ms On/100ms Off repeating (fast blink).

Occurs for several seconds in the following scenarios:

- When USB media was detected, after the controller’s BACKUP button is pressed (backup mode).
- When the controller is power cycled while holding in the BACKUP button (recovery/restore mode)

Working mode: 1s On/1s Off repeating (slow blink). Never remove power in this mode; see the [Warning](#) on page 7.

Error mode: Two quick 200ms flashes On, 3 seconds Off, repeating.

Some scenarios where the BACKUP LED is used include:

USB drive inserted — A USB flash drive is inserted in the USB 2.0 port, to either backup a *commissioned* unit to the USB drive, or to restore an existing backup from the drive. The BACKUP LED lights when the USB drive is mounted.

Backup —A backup is initiated by pressing the BACKUP button from 1 to 5 seconds before releasing, where the LED starts blinking in “alert mode” for 5 seconds. Another button press in this period starts the backup, where the LED blinks in the “working mode” pattern. When the backup completes, the LED turns Off, and the USB drive can be removed.

Boot to recover or restore image — The unit is powered up while holding in the BACKUP button, for either:

- (No USB media detected) A “factory defaults” *recovery* from an onboard partition with default image.
- (If USB media is detected) For the *restore* of a backup image on the USB flash drive. Note this also requires a serial shell connection to the controller’s Debug port.

In either case, the BACKUP LED starts blinking in “alert mode” pattern. If you release the BACKUP button during this period (within 5 seconds), initiation begins for either:

- If no USB media is detected, the “factory defaults” recovery image installation.
- If USB media is detected, the system enters “restore mode”. In this mode, after login with serial shell, a menu lists the available backup images on the USB flash drive. You can select one (and enter the unique security key to initiate its installation), or alternatively select to install the “factory defaults” recovery image.

During a recovery or restore image installation, the LED blinks in the “working mode” pattern. When the image installation completes, the BACKUP LED turns Off. A controller reboot is then required.

See the *JACE-8000 Backup and Restore Guide* document for complete details on JACE-8000 controller backups, restores, and recoveries.



Warning Do not remove power while a recovery image install or backup restore is in progress, meaning the BACKUP LED is flashing in “working mode” pattern (1s On/1s Off, or slow blink). Otherwise, the controller will be inoperable (“bricked”), and must be returned to a service center for repair.

Initiating a controller shutdown

USB ports and pushbutton switches

Behind the controller's front access door are two USB ports, two pushbutton switches, and an associated LED.

Figure 9 USB ports and switches behind access door.

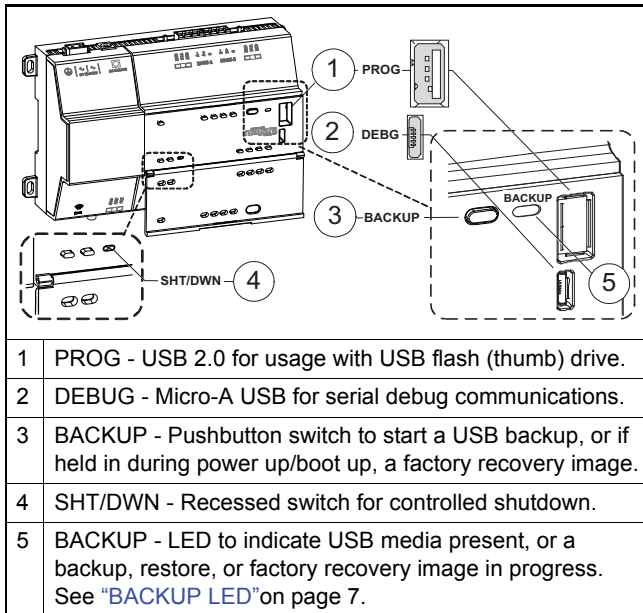

- The DEBUG port is a standard Micro-A type USB port for serial debug communications to the controller. You can use a serial terminal program (for example: PuTTY) to access the controller's "system shell" menu. This provides access to a few basic platform settings.

Default DEBUG port settings are: 115200, 8, N, 1 (baud rate, data bits, parity, stop bits). For more details see the *JACE Niagara 4 Install and Startup Guide*.



Note Login requires admin-level platform credentials.

- The SHT/DWN pushbutton initiates a "controlled shutdown" of the controller, ensuring that all station data is preserved. This provides an alternative to the platform "stop station" command, while connected online with controller. See "[Initiating a controller shutdown](#)".

Initiating a controller shutdown

When locally servicing an installed and configured (commissioned) unit, use this feature before removing power.

NOTE: Do not initiate a shutdown or remove power if:

- BACKUP LED is blinking in "working mode", or
- Beat LED is flashing at a 90%/10% on/off rate.

Instead, wait for the BACKUP LED to be in another state (typically Off), and the BEAT LED to flashing at the normal 50%/50% on/off duty cycle rate before initiating a shutdown. For related details, see "[BEAT \(Heartbeat\) LED](#)" and "[BACKUP LED](#)," page 7.

Prerequisite: Controller has been commissioned (Niagara 4 installed, platform configured, a station installed) and the unit is running the station.

- Press and hold the recessed SHT/DOWN button just until the "BACKUP" LED begins flashing in "alert mode" pattern: 100ms On/100ms Off repeating (fast blink).
- Release the SHT/DOWN button during this alert mode. This starts the shutdown process, where the station and software is put into a safe state. During this shutdown, the "BACKUP" LED blinks in "working mode".
- When shutdown is done, the "BACKUP" LED turns Off. You can safely remove 24V power from the unit.

NOTE: In the case where the system cannot be put into a safe state, the "BACKUP" LED blinks in "error mode": two quick 200ms flashes On, 3 seconds Off, repeating.

Related documentation

See the following documents for additional JACE-8000 controller information:

JACE-8000 Install and Startup Guide

Dual RS485 Option Module (12979) Install Sheet

LON Option Module (12978) Install Sheet

RS232 Option Module (12980) Install Sheet

JACE-8000 Backup and Restore Guide

JACE-8000 WiFi Guide

Data Recovery Service Guide

Niagara 4 Platform Guide

Certifications

The JACE-8000 (12977) controller has the following agency listings, compliances, and certifications:

- UL-916, Energy Management Equipment - Edition 4
- FCC Part 15, Class B - Federal Communications Commission, with FCC Part 15, Subpart C - WiFi
- ICES-003, Class B - Industry Canada Interference-Causing Equipment Standard
- RoHS 2 (Restriction of Hazardous Substances), Directive 2011/65/EU.
- CE Declaration of Conformity (Council Directive 004-108-EC)

Manufacturer Representative

Tridium Europe Ltd

1, The Grainstore

Brooks Green Road

Coolham, West Sussex

RH13 8GR United Kingdom

- ACMA, complies with the requirements of the relevant ACMA Standards.

For complete details on listings and compliances for this controller, refer to the document *Agency Listings and Approvals for Tridium Hardware Products*.

Compliance and approvals

Federal Communications Commission (FCC)

This device complies with Part 15 of the FCC Rules. Operation is subject to the following two conditions:

1. This device may not cause harmful interference, and
2. This device must accept any interference received, including interference that may cause undesired operation.

Changes or modifications not expressly approved by the party responsible for compliance could void the user's authority to operate the equipment.

This equipment has been tested and found to comply with the limits for a Class B digital device, pursuant to Part 15 of the FCC Rules. These limits are designed to provide reasonable protection against harmful interference in a residential installation. This equipment generates uses and can radiate radio frequency energy and, if not installed and used in accordance with the instructions, may cause harmful interference to radio communications. However, there is no guarantee that interference will not occur in a particular installation. If this equipment does cause harmful interference to radio or television reception, which can be determined by turning the equipment off and on, the user is encouraged to try to correct the interference by one of the following measures:

- Reorient or relocate the receiving antenna.
- Increase the separation between the equipment and receiver.
- Connect the equipment into an outlet on a circuit different from that to which the receiver is connected.
- Consult the dealer or an experienced radio/TV technician for help.

Canadian Department of Communications (DOC)

This Device complies with Industry Canada License-exempt RSS standard(s). Operation is subject to the following two conditions: 1) this device may not cause interference, and 2) this device must accept any interference, including interference that may cause undesired operation of the device.

Cet appareil est conforme à la norme d'Industrie Canada, exempts de licence standard RSS (s). Son fonctionnement est soumis aux deux conditions suivantes: 1) le dispositif ne doit pas causer d'interférences, et 2) le dispositif doit accepter toute interférence, y compris les interférences qui susceptible de provoquer un mauvais fonctionnement de l'appareil.

Under Industry Canada regulations, this radio transmitter may only operate using an antenna of a type and maximum (or lesser) gain approved for the transmitter by Industry Canada. To reduce potential radio interference to other users, the antenna type and its gain should be so chosen that the equivalent isotropically radiated power (e.i.r.p.) is not more than that necessary for successful communication.

En vertu des règlements d'Industrie Canada, cet émetteur de radio ne peut fonctionner qu'en utilisant une antenne d'un type et maximale (ou moins) gain approuvé pour l'émetteur d'Industrie Canada. Pour réduire les interférences radio potentielles aux autres utilisateurs, le type d'antenne et son gain doivent être choisis afin que la puissance isotrope rayonnée équivalente (e.i.r.p.) ne soit pas plus que ce qui est nécessaire pour une communication réussie.

The device for operation in the band 5150–5250 MHz is only for indoor use to reduce the potential for harmful interference to co-channel mobile satellite systems.

Les dispositifs fonctionnant dans la bande 5150-5250 MHz sont réservés uniquement pour une utilisation à l'intérieur afin de réduire les risques de brouillage préjudiciable aux systèmes de satellites mobiles utilisant les mêmes canaux

Approved Antenna Listing

- ANT-DB1-RAF-RPS

Transmitter Module Listing

- Contains Transmitter Module FCC ID: W98-12977
- Contains Transmitter Module IC: 8339A-12977

Tab mounting dimensions

Measurements shown below are in inches and (mm). Note that DIN mounting is recommended over tab mounting. See “Mounting on DIN rail,” page 4.

Figure 10 JACE-8000 controller tab mounting dimensions.

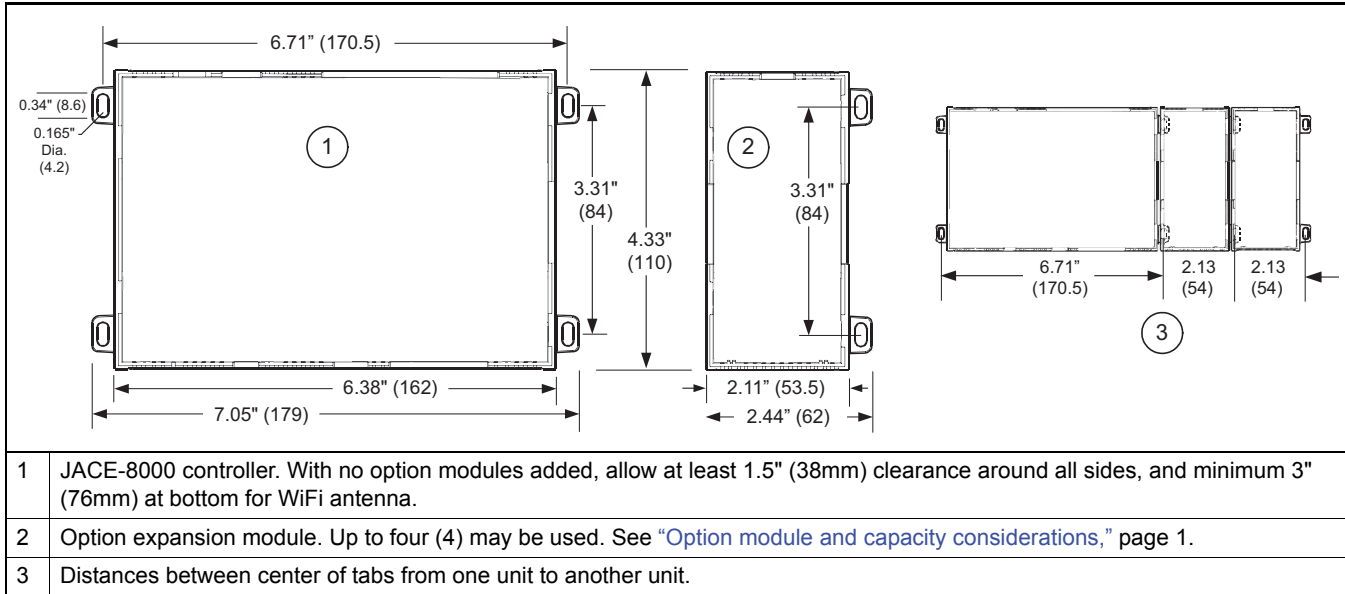

Information and/or specifications published here are current as of the date of publication of this document. Tridium, Inc. reserves the right to change or modify specifications without prior notice. The latest product specifications can be found by contacting our corporate headquarters, Richmond, Virginia. Products or features contained herein are covered by one or more U.S. or foreign patents. This document may be copied by parties who are authorized to distribute Tridium products in connection with distribution of those products, subject to the contracts that authorize such distribution. It may not otherwise, in whole or in part, be copied, photocopied, reproduced, translated, or reduced to any electronic medium or machine-readable form without prior written consent from Tridium, Inc. Complete confidentiality, trademark, copyright and patent notifications can be found at: <http://www.tridium.com/galleries/SignUp/Confidentiality.pdf>. © 2016 Tridium, Inc.