

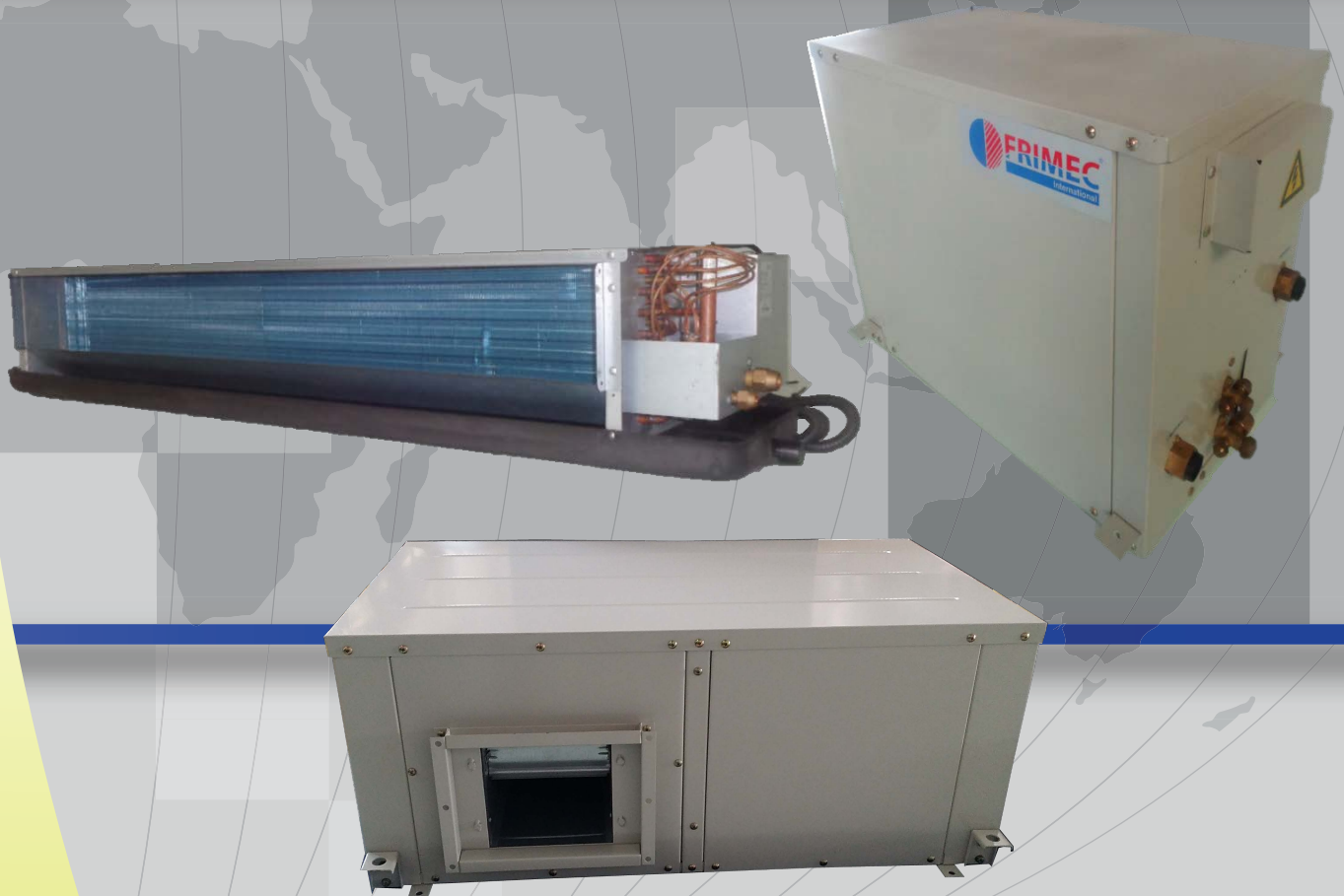

WATER-COOLED DUCTED (CEILING HUNG)

Models: FWSN/FWSD 010-050
FWLP 010-100



Contents

Product Nomenclature.....	3
Features.....	5
Engineering Specifications.....	7
General Data.....	7
Operating Range.....	9
System Schematic Diagram.....	10
Controller Features and Algorithm.....	12
Dimensions.....	22
Wiring Diagram.....	28
Installation.....	38
Service and Maintenance.....	45
Troubleshooting.....	46

Product Nomenclature

Water-Cooled Split Ducted Indoor Unit

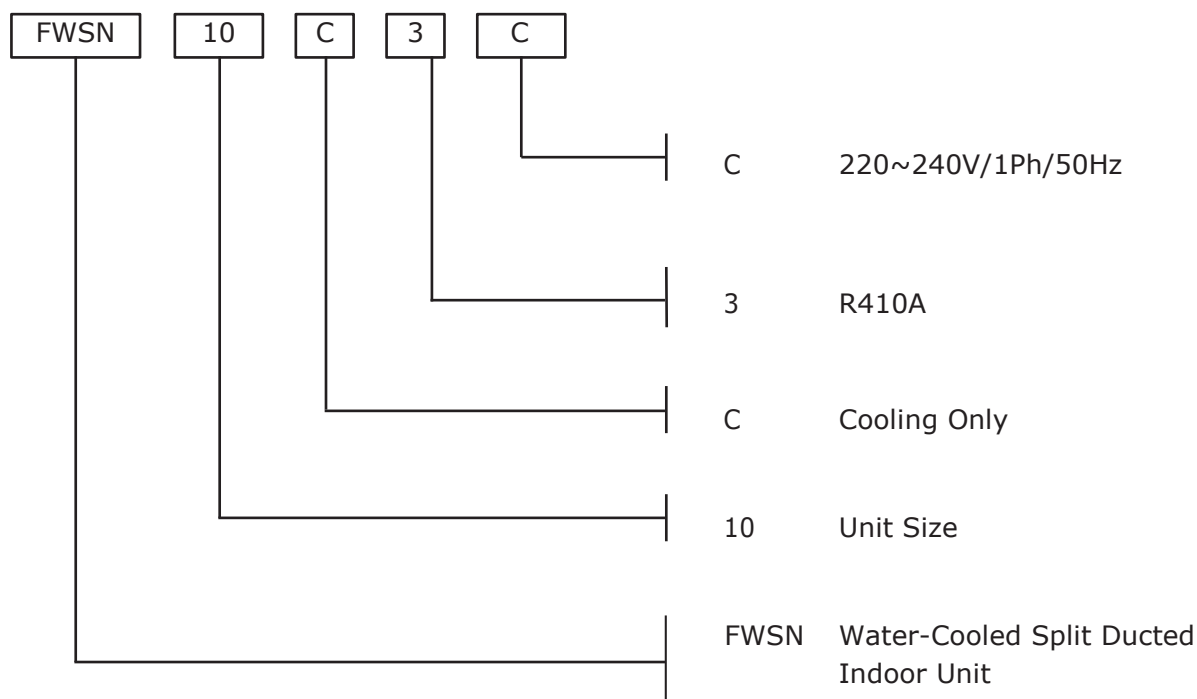

Water-Cooled Split Ducted Outdoor Unit

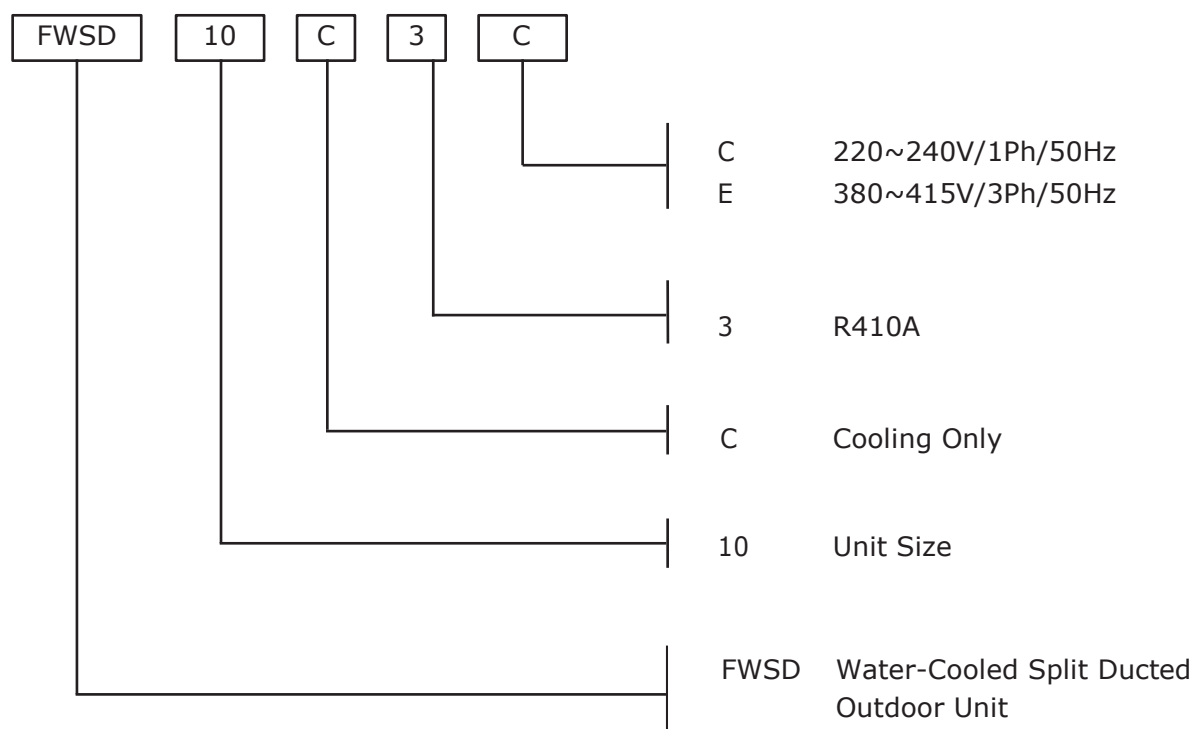

Water-Cooled Packaged Unit

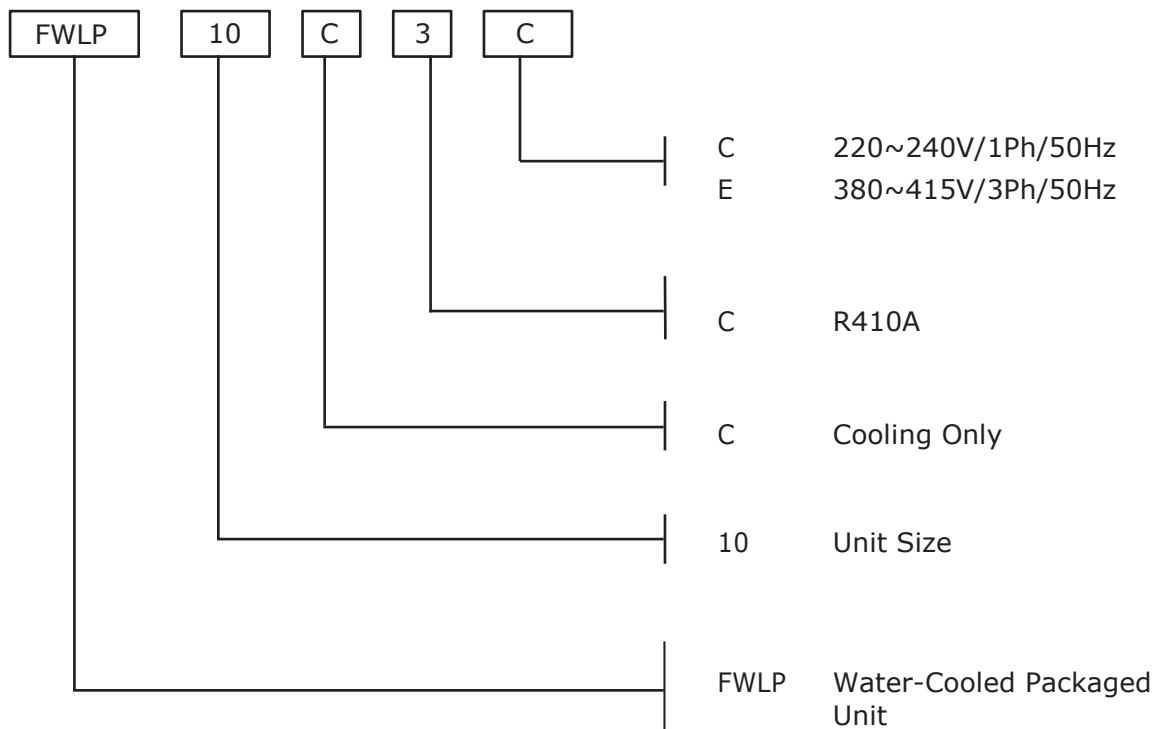

Features

**Energy Saving
and High
Efficiency**

Water-Cooled ducted unit uses water as the cooling medium which has higher efficiency than air. Simultaneous cooling can be achieved through water loop system, providing comfort and cost saving all year round. Energy can be transferred easily in the system providing excellent solution to diversity effect.

Low Noise

Without the need of air for cooling can be installed in any place. Thus, air noise has been totally eliminated and proper installation location with noise barrier can be selected. Specially designed casing with vibration absorption material and insulated and separated compartment for compressor and supply air contribute further to the superb low noise performance.

Economics

Compared with ordinary central air conditioners, the unit does not require service rooms nor ventilation ducts. The unit is assembled at the factory and the water piping system does not require additional insulation. The unit also comes with a temperature controller that does not require an additional controller or control room.

**Convenient
Operation
and
Maintenance**

The installation and operation are easy. The flexible and durable design greatly reduces the failure rate and the need for frequent service. Even if there is a faulty unit in the system, other units in the system will not be affected thus increased operability and reduced downtime.

**Flexible
Application**

Main water pipes can be installed during building construction and water cooled split can be installed in the later stage. Different capacity and unit design can be decided during renovation which offers greater flexibility and convenience.

Simple Control

The system is controlled by microcomputer which offers accurate and simple operation. Independent control for each unit provide convenient and comfort to each room without affecting others.

Water-Cooled Ducted Unit Working Principles

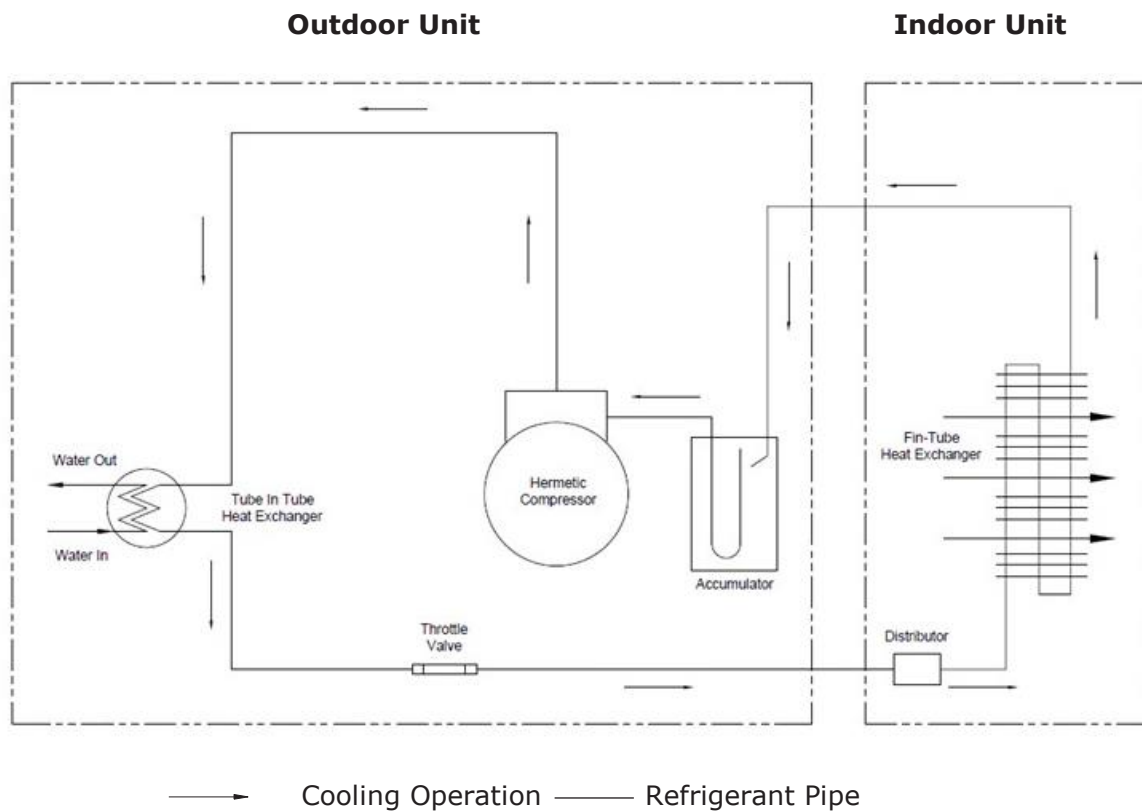

Cooling cycle

High pressure refrigerant is discharged from compressor to tube-in-tube heat exchanger. Functioning as a condenser, the tube-in-tube heat exchanger cools down the refrigerant through cool water supplied from cooling tower. Water temperature will rise about 5~6°C. Liquid refrigerant will then pass through throttle valve, metering device and reach the fin-tube heat exchanger, which acts as an evaporator. Evaporator will subsequently evaporize the cool refrigerant through absorbing heat from the conditioned space. The evaporized and superheated refrigerant will be pumped back to the compressor and continues the cycle again from the beginning.

Engineering Specification

General Data - Water-Cooled Split Ducted Unit

Model	Indoor Unit	FWSN	10	15	18	20	25	30	40	50		
	Outdoor Unit	FWSD	10	15	18	20	25	30	40	50		
Cooling Capacity		kW	2.90	4.20	5.60	6.40	7.60	8.60	11.80	14.00		
		Btu/h	9,900	14,400	19,100	22,000	26,000	29,300	40,200	48,000		
Indoor Unit	Air Volume	High Speed	CMH	525	750	980	1150	1350	1750	1900	2550	
		Medium Speed	CMH	435	640	825	950	1030	1500	1400	1900	
		Low Speed	CMH	230	450	500	720	740	1100	900	1000	
	External Static Pressure		Pa	30							60	
	Dimension	Length	mm	705		995		1435		1635	1635	
		Width	mm	470							520	
		Height	mm	240							290	
	Condensed Water Drain Pipe		mm (in)	DN20 (3/4")								
	Supply Air Flange Dimension		mm	490*130	490*130	780*130	780*130	1185*130	1185*130	1380*130	1380*180	
	Weight		kg	21	23	23	24	29	34	39	49	
Sound Pressure Level		dB(A)	41	43	44	46	47	49	51	52		
Power Supply		V/Ph/Hz	220~240/1/50									
Compressor Type			Rotary						Scroll			
Compressor Qty			1									
Outdoor Unit	Condenser	Type	Tube in Tube									
		Water Flow Rate	m ³ /h	0.65	0.89	1.25	1.30	1.58	1.87	2.47	3.2	
			L/s	0.18	0.25	0.35	0.36	0.44	0.52	0.69	0.89	
		Water Pressure Drop	kPa	28.00	36.20	30.00	28.80	46.80	17.70	33.40	20.00	
	Water Inlet/Outlet Pipes		mm (in)	DN20 (3/4")						DN25 (1")		
	Dimension	Length	mm	517	517	517	517	644	644	737	737	
Width		mm	263	263	263	263	346	346	391	391		
Height		mm	401	401	440	440	516	516	522	522		
Weight		kg	30	33	36	36	47	51	80	82		
Sound Pressure Level		dB(A)	34	36	36	36	38	38	39	39		
Power Supply		V/Ph/Hz	220~240/1/50						380~415/3/50			
Power Input		kW	0.66	0.98	1.38	1.72	1.71	2.22	2.83	3.89		
Running Current		A	3.10	4.60	6.30	7.80	7.80	10.20	5.44	7.40		
Refrigerant	Type		R410A									
	Amount	kg	0.55	0.71	0.98	0.98	1.30	1.40	1.80	1.80		
Refrigerant Pipes	Liquid Pipe	mm (in)	6.35 (1/4")	6.35 (1/4")	6.35 (1/4")	9.52 (3/8")	9.52 (3/8")	9.52 (3/8")	9.52 (3/8")	12.70 (1/2")		
	Suction Pipe	mm (in)	9.52 (3/8")	12.70 (1/2")	15.88 (5/8")	15.88 (5/8")	15.88 (5/8")	15.88 (5/8")	19.05 (3/4")	19.05 (3/4")		

Notes :

- Products are tested in according to GB/T 19409-2003(ISO 13256:1998).
- Cooling capacity is based on 26.7°C DB/19.4°C WB for indoor air.
- External static pressure data published is for standard unit.
- The manufacturer reserves the right to change the specification without prior notice.
- All performance data tested based on high speed air volume.

General Data - Water Cooled Package Unit

Model	FWLP		10	15	20	25	30
Cooling Capacity		kW	2.63	4.07	6.20	7.32	8.40
Power Input		kW	0.68	0.93	1.61	2.00	2.12
Current		A	3.19	4.60	7.50	9.10	9.80
Air Volume		m³/h	580	800	1080	1250	1650
External Static Pressure		Pa	30				
Dimension	Length	mm	962		1192	1192	
	Width	mm	637		677	700	
	Height	mm	416		451	550	
	Condensation Water Pipe	mm(in)	DN20 (3/4")				
	Filter Dimension	mm	370 x 314 x 10		267 x 354 x 10	265 x 456 x 10	
	Filter Qty		1		2	2	
Condenser	Type		TUBE IN TUBE				
	Water Flow Rate	m³/h	0.65	0.90	1.40	1.60	1.90
	Water Pressure Drop	kPa	28.0	47.0	32.0	45.0	18.0
	Water Inlet/outlet Pipe	mm(in)	DN20 (3/4")				
Panel Type		Single Skin					
Weight		kg	72	77	94	100	115
Power Supply		V/Ph/Hz	220~240/1/50				
Refrigerant	Type		R410A				
	Amount	kg	0.55	0.71	0.98	1.30	1.40

Model	FWLP		40	50	70	100
Cooling Capacity		kW	12.39	14.50	18.18	30.00
Power Input		kW	2.99	3.75	5.04	7.51
Current		A	7.20	8.50	12.50	17.0
Air Volume		m³/h	1900	2550	3300	5300
External Static Pressure		Pa	30	80		
Dimension	Length	mm	1365		1678	2268
	Width	mm	871		993	1212
	Height	mm	550		658	708
	Condensation Water Pipe	mm(in)	DN25 (1")			
	Filter Dimension	mm	365 x 443 x 10		524 x 428 x 10	572 x 306 x 10
	Filter Qty		2		2	4
Condenser	Type		TUBE IN TUBE			
	Water Flow Rate	m³/h	2.60	3.20	3.90	6.54
	Water Pressure Drop	kPa	40.0	20.0	43.8	26.4
	Water Inlet/outlet Pipe	mm(in)	DN20(3/4")	DN25 (1")		DN32(1 ¼")
Panel Type		Single Skin		Double Skin		
Weight		kg	166	171	195	300
Power Supply		V/Ph/Hz	380~415/3/50			
Refrigerant	Type		R410A			
	Amount	kg	1.80	1.80	2.20	1.80 x 2

Notes :

1. Products are tested in according to GB/T 19409-2003(ISO 13256:1998).
2. Cooling capacity is based on 26.7°C DB/19.4°C WB for indoor air.
3. External static pressure data published is for standard unit.
4. The manufacturer reserves the right to change the specification without prior notice.
5. All performance data tested based on high speed air volume.

Operating Range

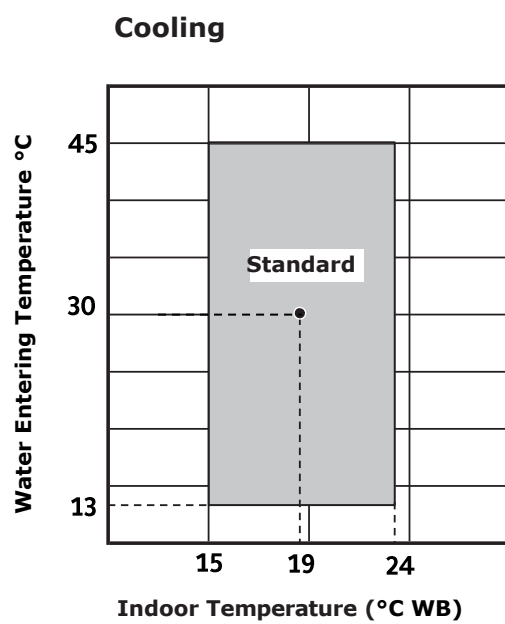

System Schematic Diagram

Model : FWSN/FWSD 10 / 15 / 18 / 20 / 25 / 30 / 40 / 50

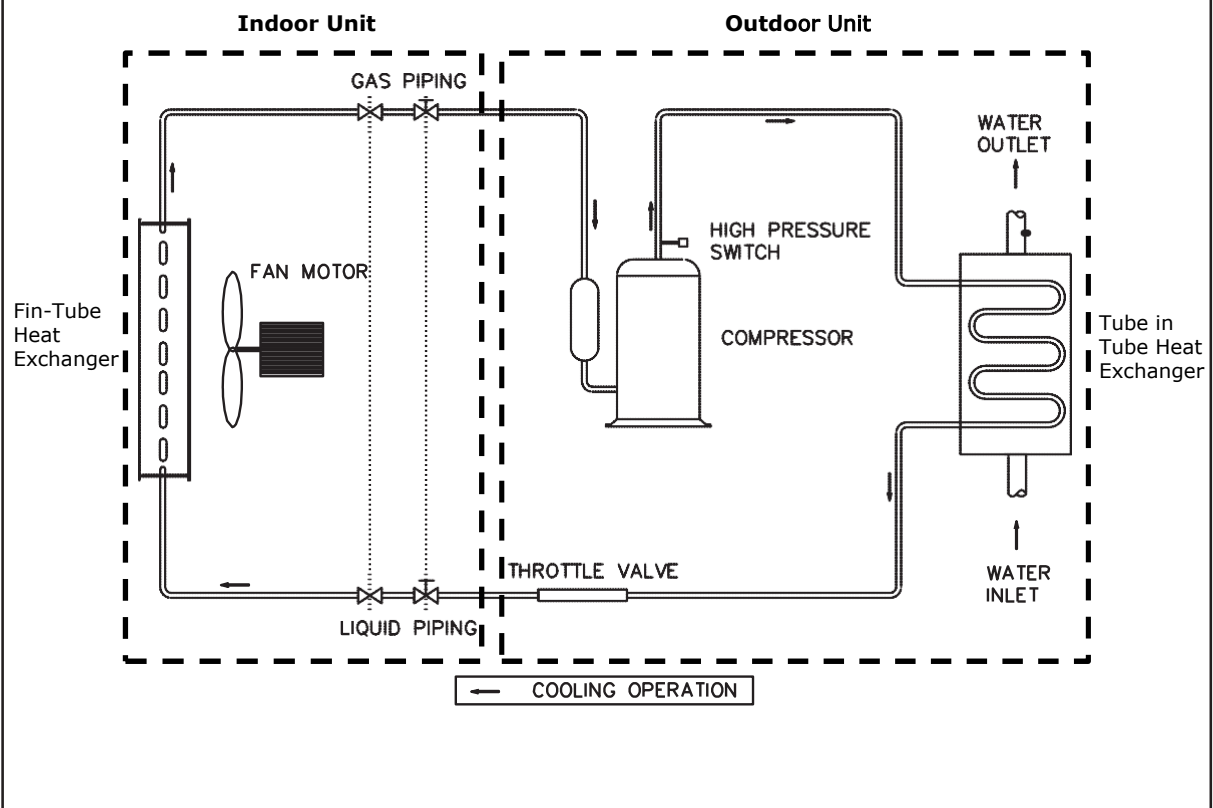

System Schematic Diagram

Model : FWLP 10 / 15 / 20 / 25 / 30 / 40 / 50 / 70

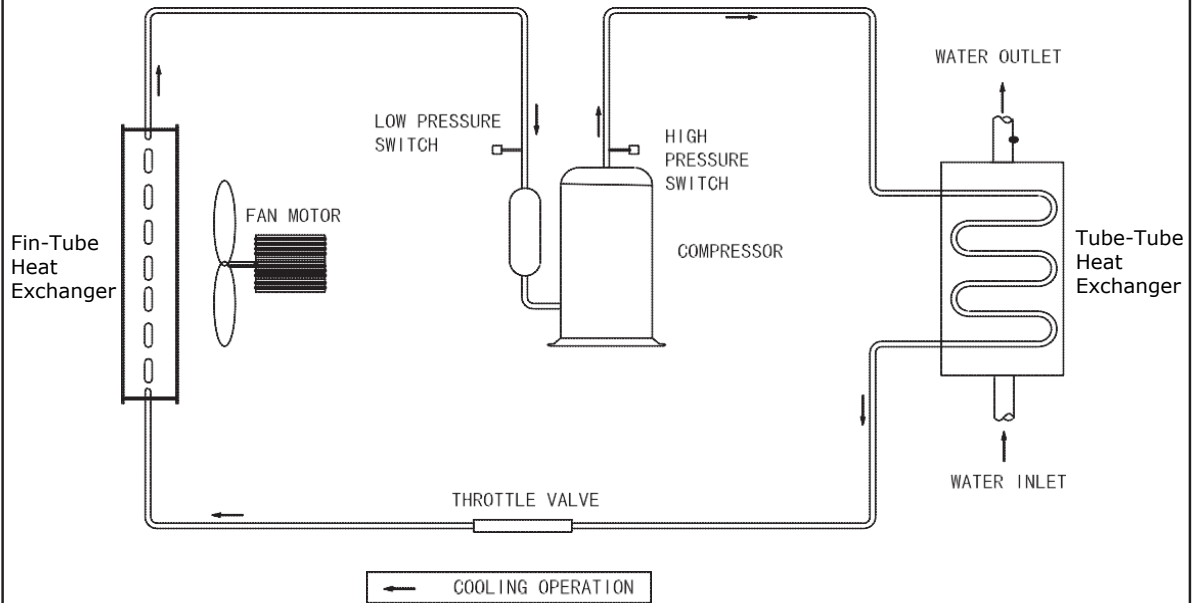

Model : FWLP 100

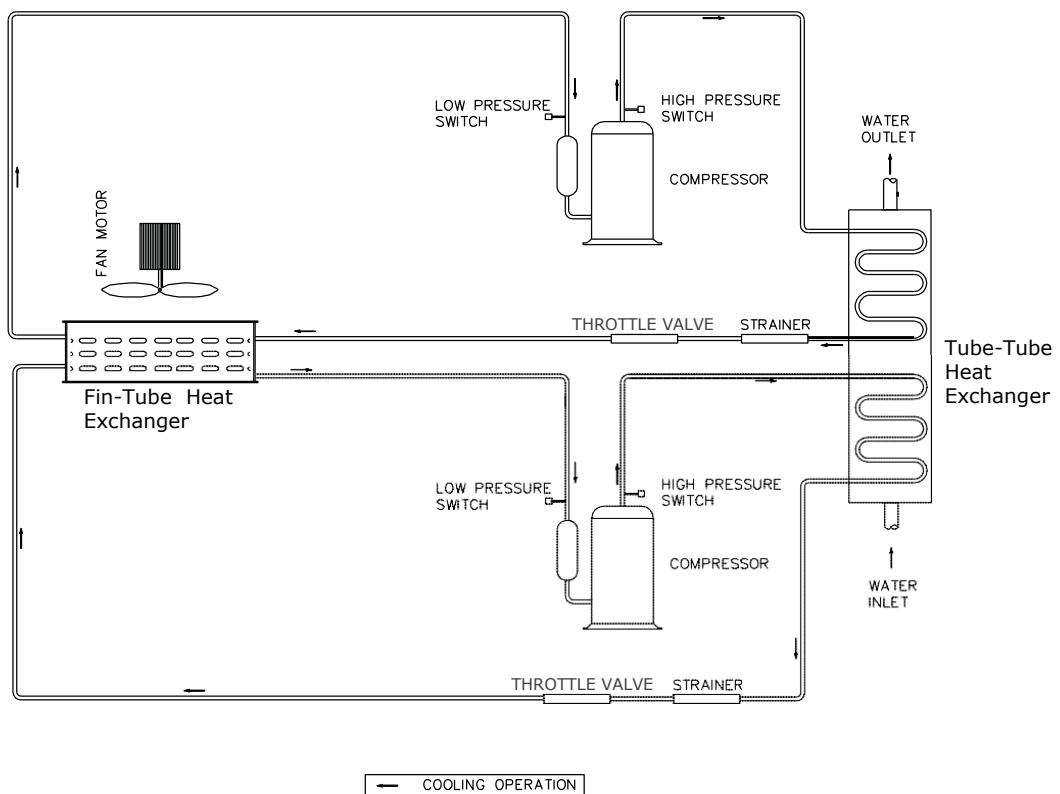

Wired LCD Controller Features

a) Single Circuit



1. On/Off

1.1. Press 《》 button to on/off the unit

2. Mode of Operation

2.1. Press 《》 button to change the mode of operation

2.2. Toggle through cool→fan →dry →heat →auto

2.3. Heat and auto mode is not available in cooling only model

3. Blower Speed





3.1. Press 《》 button to change the speed

3.2. Toggle through low →medium →high →auto

3.3. Speed selection not available in dry mode (Operates in low speed as default)

3.4. Auto speed is not available in fan mode



4. Temperature Setting

- 4.1. Press 《》 or 《》 once will flash the current set temperature
- 4.2. Press again 《》 or 《》 button to adjust the temperature setting (16°C – 30°C)



5. Sleep Mode

- 5.1. In cool, heat or auto mode press 《》 button to enable or disable sleep function
- 5.2. Sleep function will be cancelled automatically after 8 hours



6. Timer

- 6.1. Press 《》 button once to initiate the timer (symbol blinks)
- 6.2. Error code display area shows "--" means no timer setting available
- 6.3. Press 《》 or 《》 button to set the timer in hour
- 6.4. When timer setting reduce to zero, it will be indicated as "--"
- 6.5. After exit timer setting mode, timer symbol will light up if timer setting is programmed

7. Cancel

- 7.1. In any menu press 《》 button to exit the current menu
- 7.2. Hold down 《》 button for 3sec to cancel the timer setting

8. Key Lock

- 8.1. Hold 《》 button for 3s to initiate key lock
- 8.2. Only 《》 button is valid during key locked
- 8.3. Repeat 8.1 to disable key lock

9. Parameters Check

9.1. During key lock, hold 《 ❄️ 》 and 《 △ 》 button for 3s to browse the following temperature

Temperature area	Error code area
C0	Return air temperature
C1	Indoor coil temperature
C2	Outdoor coil/Leaving water temperature
C3	Outdoor ambient/Entering water temperature

9.2. Press 《 △ 》 or 《 ▽ 》 button to select temperature to read

9.3. Press 《 ↻ 》 button to exit

10. Celsius and Fahrenheit Selection

10.1. During key lock, hold 《 △ 》 and 《 ▽ 》 button for 3s to toggle between Celsius and Fahrenheit

11. Hardware Test Mode

11.1. Within 1 minute upon power on, hold 《 ❄️ 》 and 《 ↻ 》 button for 3s toggle between Celsius and Fahrenheit

11.2. All segments on wall pad will light up

11.3. Press any button will trigger the wallpad to beep and send a test command to the main board

12. System control parameter

12.1. During key lock, hold 《❄️》 and 《🌙》 button for 3s to enter following menu.

Temperature Area	Error Code Area	Remarks
d0	Defrost terminate temperature	Set : 10°C ~ 30°C Default : 18°C
d1	Defrost termination time	Set : 5 ~ 20 min Default : 10 min
d2	Cool mode water protection temp	Set : 0°C ~ 20°C Default : 4°C
d3	Heat mode water protection temp	Set : -10°C ~ 30°C Default : 4°C
d4	Slave unit address	Set : 0 ~ 99 Default: 0
d5	Temperature differential protection	Set : 0°C ~ 20°C Default : 10°C
d6	0 = Default off 1 = Last state memory	Default : 0
d7	0 = Defrost mode 1 1 = Defrost mode 2	Default : 0
d8	0 = Disable entering water function 1 = Enable entering water function	Default : 0
d9	0 = Disable cold draft prevention 1 = Enable cold draft prevention	Default : 1
dA	Cold draft offset	Set : 0°C ~ 10°C Default: 0°C
db	0 = Disable gas leak check 1 = Enable gas leak check	Default : 1

12.2. Press 《❄️》 button to select the desired item

12.3. Press 《△》 or 《▽》 button to adjust the selected value

12.4. Upon completion hold 《❄️》 and 《🌙》 button for 3s to exit and save the settings

12.5. Press 《🔄》 button to exit without save

13. Error codes

Fault	Error code
Insufficient refrigerant	4
Return air temperature sensor error	5
Indoor coil temperature sensor error	6
Outdoor coil temperature sensor error	7
Compressor overload	8
Condensing water temperature protection	9
Low pressure protection	10
High pressure protection	11
Outdoor ambient air/Entering water temperature sensor error	12
Flow switch error	17
Entering and leaving water temperature difference protection	18
Indoor coil anti freeze protection	25
Indoor coil overheat protection	26
Communication error	48

13.1. When multiple errors occur



13.1.1. All error codes will be displayed one after another

13.2. Heat symbol flashes during outdoor coil defrosting

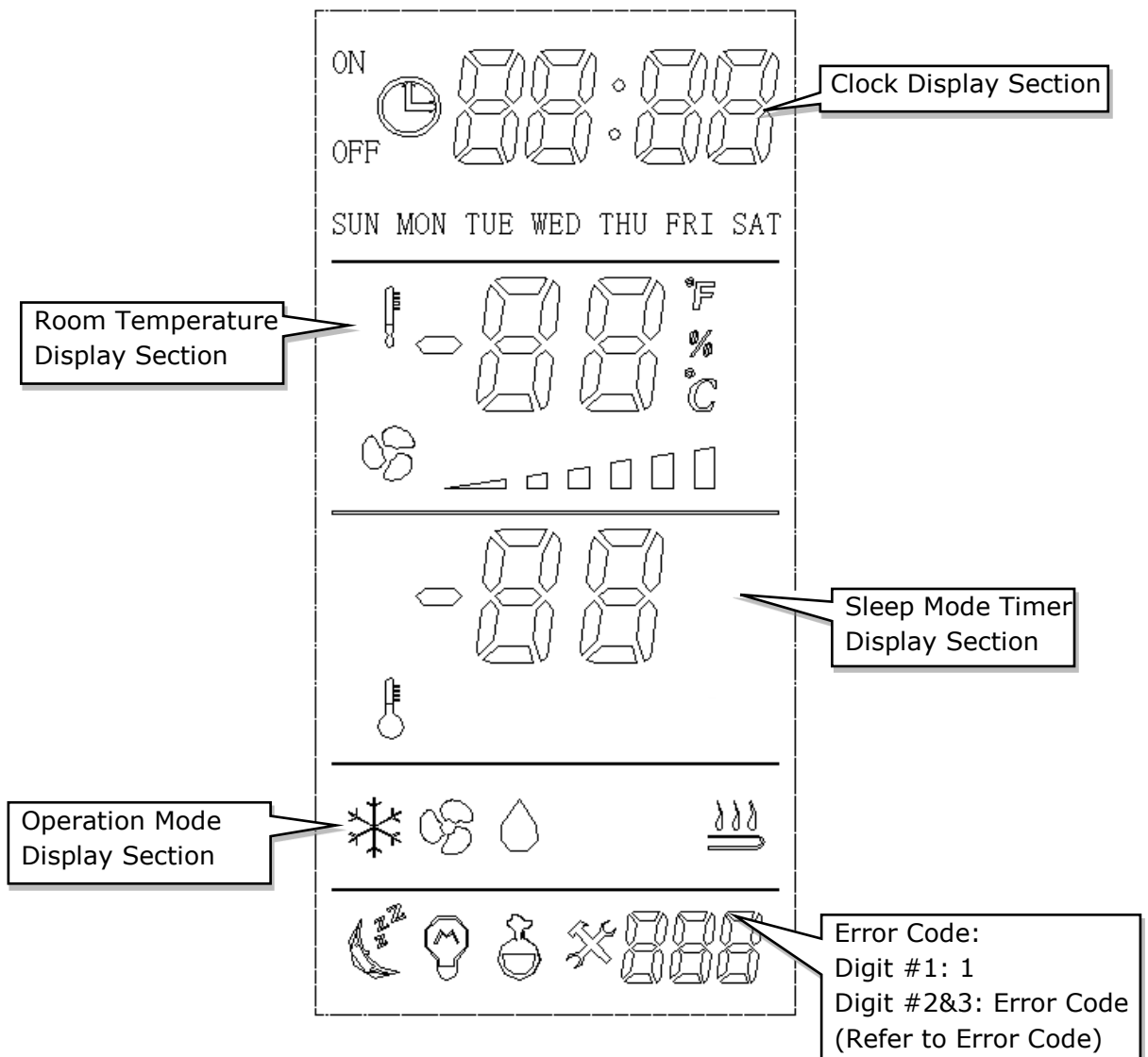
b) Double Circuit (FWLP100 only)



1. On/Off

- 1.1 Press  button; unit will start function
- 1.2 Press again  button; unit will stop function







2. Mode

- 2.1 Press  button to change the mode of operation
- 2.2 Toggle through Cool →Fan →Dry→Hot Water (Not Applicable)

3. Blower Speed

- 3.1 Press  button to change the blower speed
- 3.2 Toggle through Auto →Low →Medium →High



4. Sleep Mode

- 4.1 Press  button once to enable or disable sleep mode function ( symbol blink). Sleep mode function will be disabled when editing mode of operation, temperature and On/Off unit
- 4.2 Sleep mode timer display section shows  (8hrs)
- 4.3 Press  button to increase 1 hour (Max 12 hours)
- 4.4 Press  button to decrease 1 hour (Min 1 hour)
- 4.5 Press  button to save the setting and exit
- 4.6 Press  button to exit



5. Energy Saving

- 5.1 Press  button to enable or disable energy saving function
- 5.2 Energy saving function will be disabled automatically when editing mode of operation, temperature and On/Off unit

6. Set Temperature

- 6.1 Press  or  button to adjust the temperature (16C to 30C. default 24C), temperature display section will flash the temp setting

7. Key Lock



- 7.1 Press  and  button for 1sec to activate this function with symbol  light up. Follow the same sequence to exit key lock. In key lock mode, user is allowed to access to on/off key only

8. Real Time Clock

8.1 Press  button for 3sec to enter this submenu

i. Press  button to change the day of week:

SUN-MON-TUE-WED-THU-FRI-SAT
 _____

ii. Press  or  button to change the clock:



00:00—00:01.....—23:58-- 23:59
 _____

iii. Press  button for 1sec to save the setting

iv. Press  button for 3sec to exit without saves the setting



9. On/Off Timer

9.1 If On/Off Timer being programmed,  will light up

9.2 Press  button for 6sec to into this submenu with  symbol flashing

i. Press  button to select the day of week:



SUN-MON-TUE-WED-THU-FRI-SAT
 _____



ii. Press  or  button to select the clock:

00:00—00:01.....—23:58-- 23:59
 _____



iii. Press  button for 1sec to switch On timer or Off timer, clock display section will shows On/OF

iv. Press  button for 1sec to save the setting and exit

v. Press  button for 3sec to cancel the current setting, clock display section will shows 

vi. Press  button for 6sec to delete all setting, all day of week will light up, clock display section will show 

10. Compressor Status Display

10.1 Press  and  buttons for 3sec to into the submenu with  shows in room temp. display section

- 10.2 Press «▲» or «▼» button to shows compressor no.1 or 2 statuses in clock display section
- 10.3 1(2):On(OFF) means compressor 1(2) is ON (OFF)
- 10.4 Press «X» button for 3sec to exit.

11. Parameters Check

- 11.1 Press «» and «M» buttons for 3sec to browse the following temperature:

No	Parameter (C°)
1	Return air temperature
2	N/A
3	Outdoor leaving water temperature
4	Indoor coil temperature no.1
5	Indoor coil temperature no.2
6	N/A

- 11.2 Press «▲» or «▼» button to select temperature
- 11.3 Press «X» button for 3sec to exit

12. Error/Protect Code Display

- 12.1 Symbol 《✖》 will light up and display error code when there is any system failure
- 12.2 When multiple errors occur, all error codes will be displayed one after another
- 12.3 Press 《X》 button to clear the error
- 12.4 Error Code:

No.	Error Code	Fault
1	01	Filter dirty
2	02	Sys.1 indoor coil temp. sensor failure
3	03	Condensing water flow switch failure
4	04	Sys.1 insufficient refrigerant
5	05	N/A
6	06	N/A
7	07	Condensing water temp. too low
8	08	Condensing water temp. too high
9	09	Sys.1 low pressure protection
10	10	Sys.2 low pressure protection
11	11	N/A
12	12	Filter dirty
13	13	Sys.1 high pressure protection
14	14	Sys.2 high pressure protection
15	15	N/A
16	16	N/A
17	17	Sys.2 indoor coil temp. sensor failure
18	18	Sys.2 insufficient refrigerant
19	19	N/A
20	20	N/A
21	21	N/A
22	22	N/A
23	23	N/A
24	24	Return air temperature sensor error
25	25	N/A
26	26	N/A
27	27	N/A
28	28	N/A
29	29	Outdoor leaving water temp. sensor failure

Dimensions

Model : FWSN 10 / 15

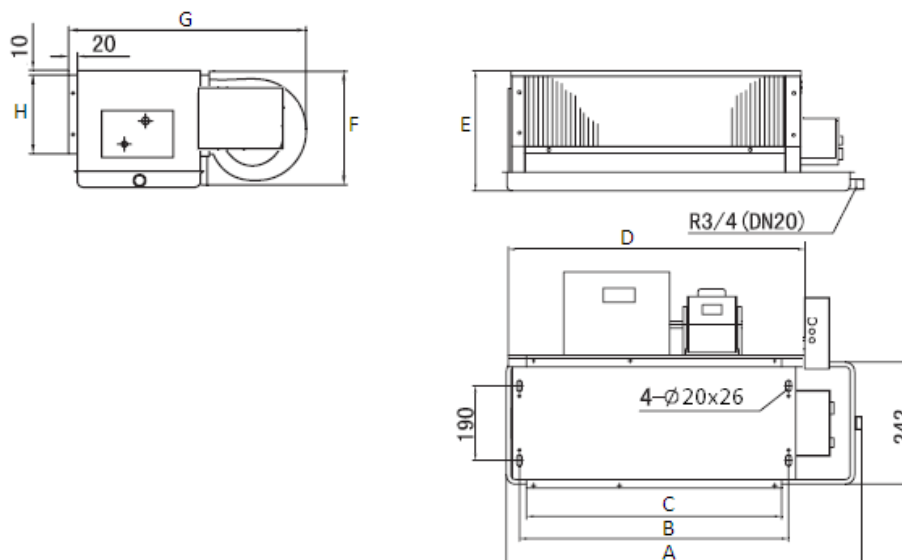

Model	A	B	C	D	E	F	G	H
FWSN 10 / 15	705	530	490	532	240	235	470	135

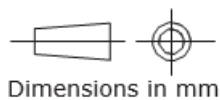

Model : FWSN 18 / 20

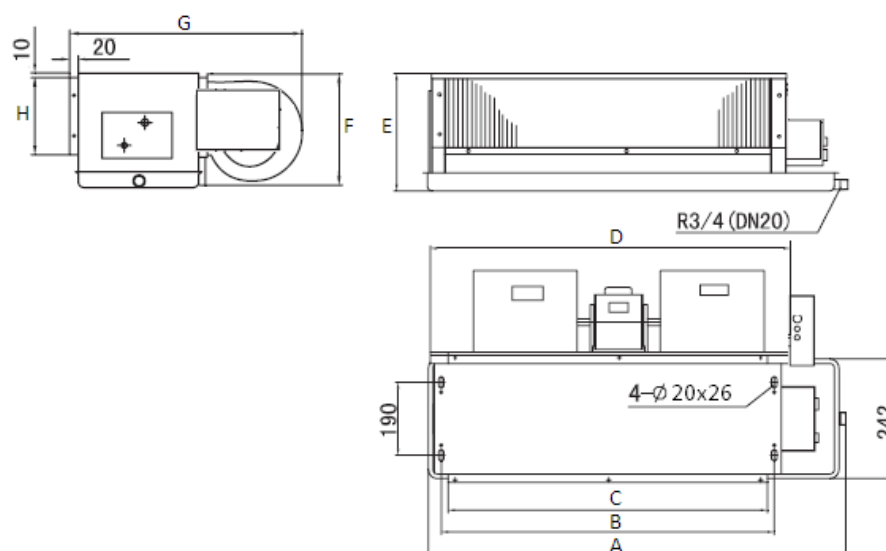

Model	A	B	C	D	E	F	G	H
FWSN 18 / 20	995	820	780	825	240	235	470	135

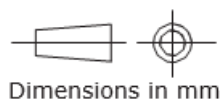

Model : FWSN 25

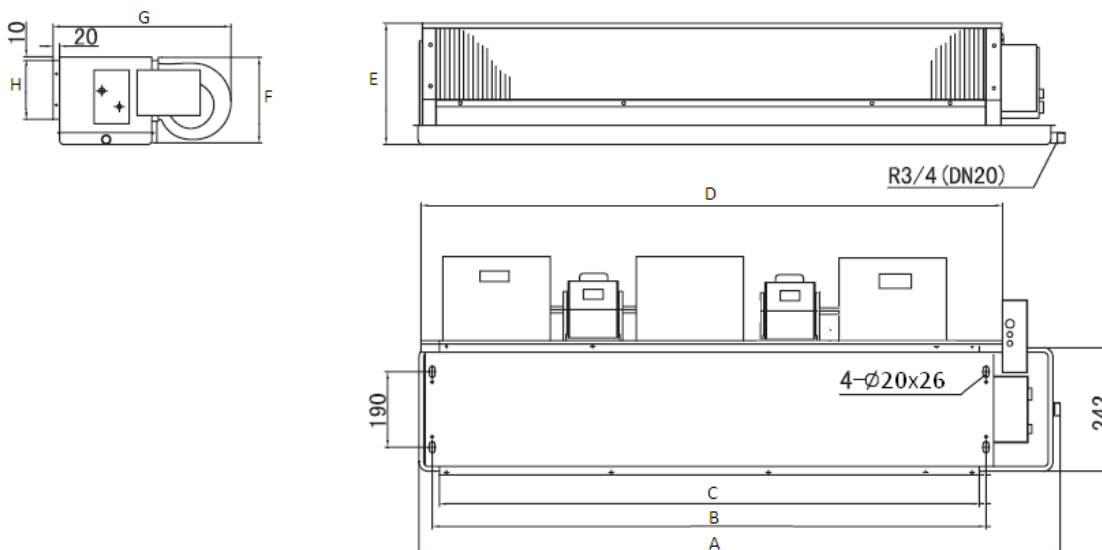

Model	A	B	C	D	E	F	G	H
FWSN 25	1435	1225	1185	1227	240	235	470	135

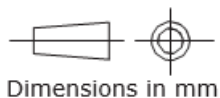

Model : FWSN 30 / 40 / 50

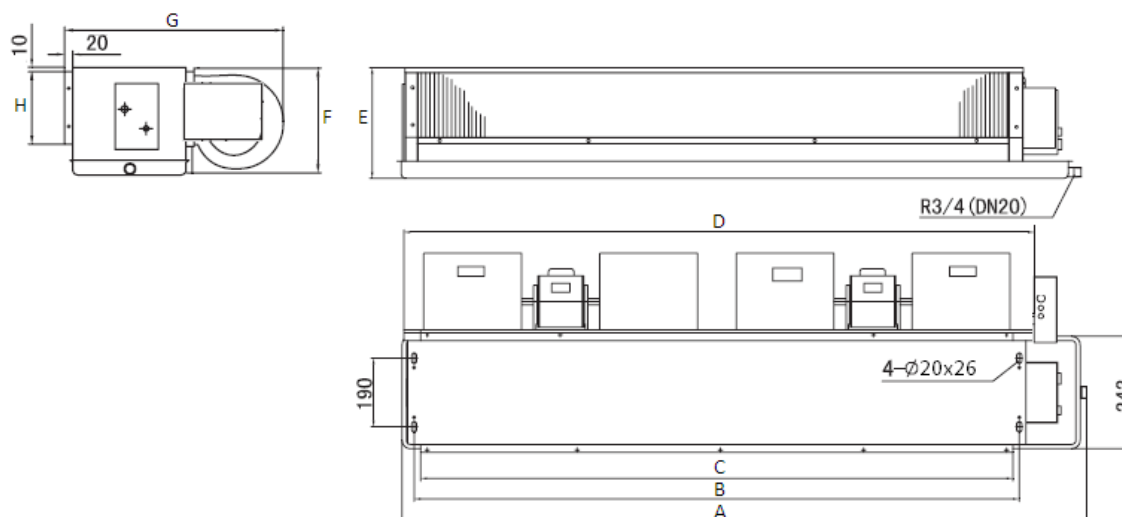

Model	A	B	C	D	E	F	G	H
FWSN 30	1435	1225	1185	1227	240	235	470	135
FWSN 40	1635	1420	1380	1422	240	235	470	135
FWSN 50	1635	1420	1380	1490	290	295	520	185

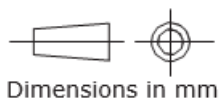

Model : FWSD 10 / 15 / 18 / 20 / 25 / 30

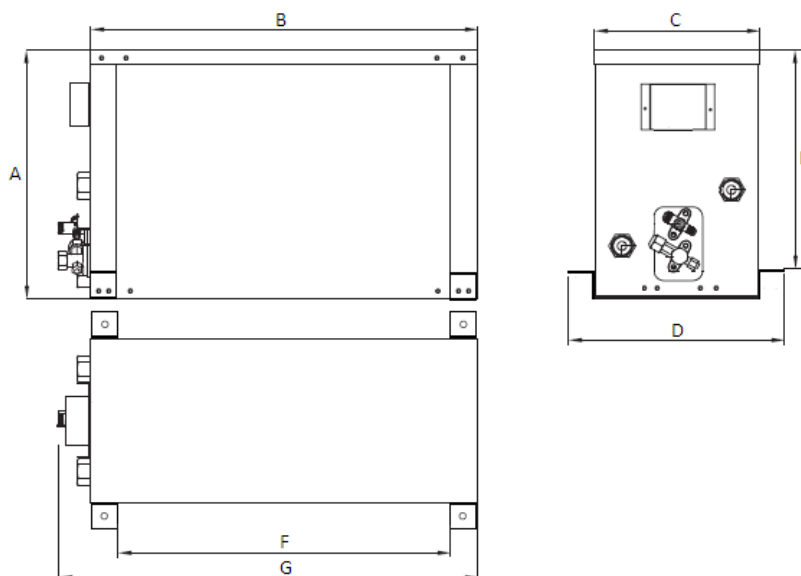

Model	A	B	C	D	E	F	G
FWSD10	401	480	263	340	360	385	517
FWSD15	401	480	263	340	360	385	517
FWSD18/20	440	480	263	340	400	385	517
FWSD25/30	516	600	346	430	480	505	644

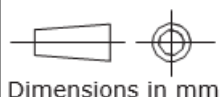

Model : FWSD 40 / 50

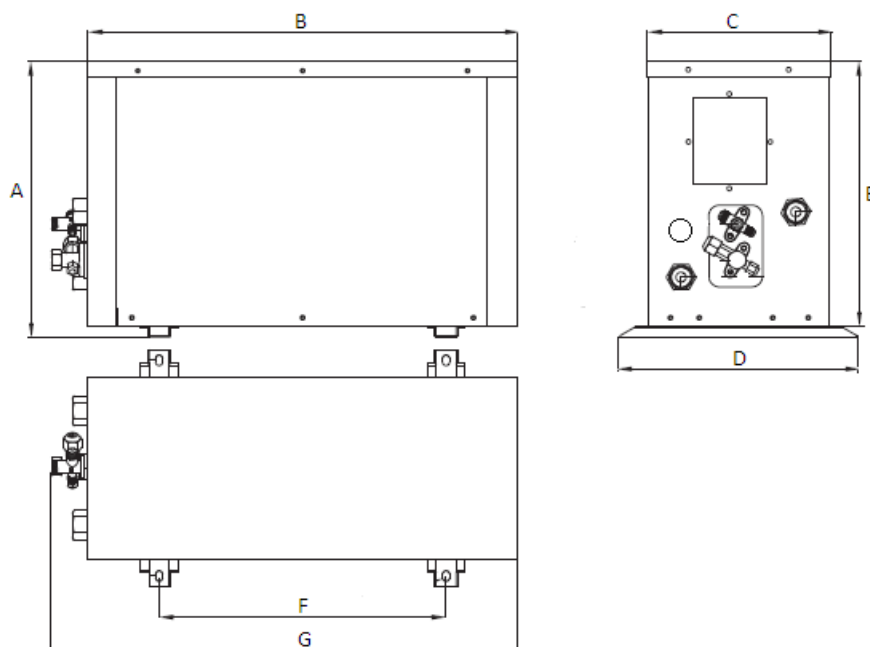

Model	A	B	C	D	E	F	G
FWSD40	522	680	391	450	510	500	737
FWSD50	522	680	391	450	510	500	737

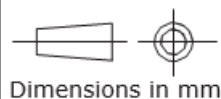

Model : FWLP 10 / 15

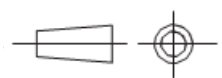
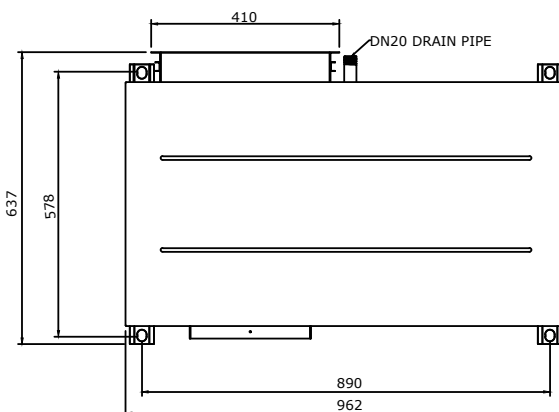
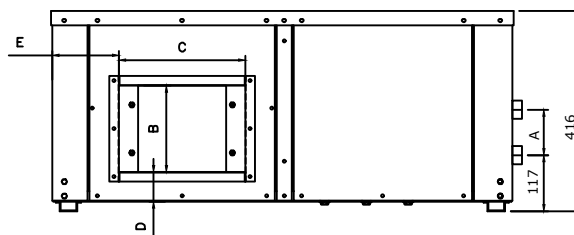
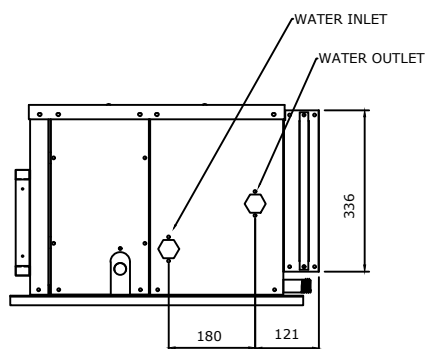

Dimensions in mm

Model	A	B	C	D	E
FWLP 10	94	180	263	62	139
FWLP 15	91	180	263	62	139

Model : FWLP 20

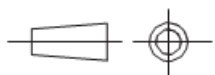
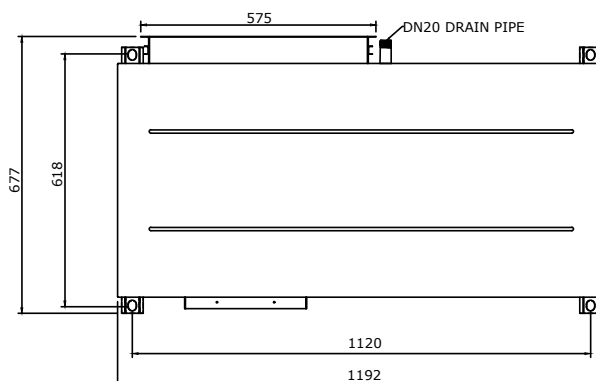
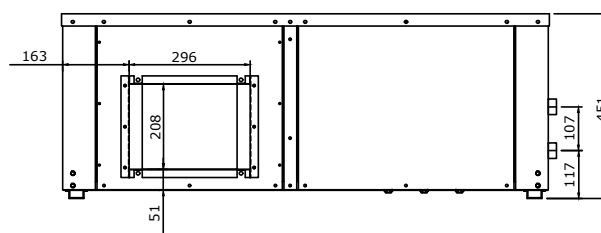
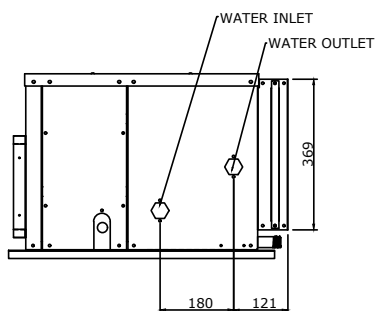

Dimensions in mm

Model : FWLP 25 / 30

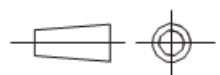
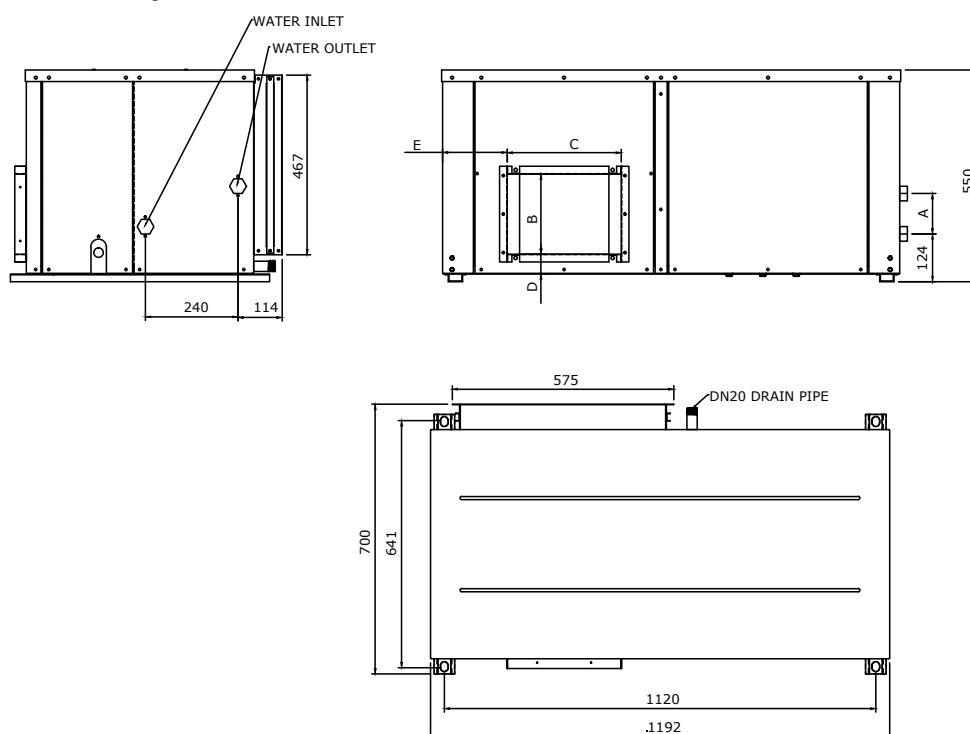

Dimensions in mm

Model	A	B	C	D	E
FWLP 25	105	208	296	52	168
FWLP 30	116	256	342	52	145

Model : FWLP 40 / 50

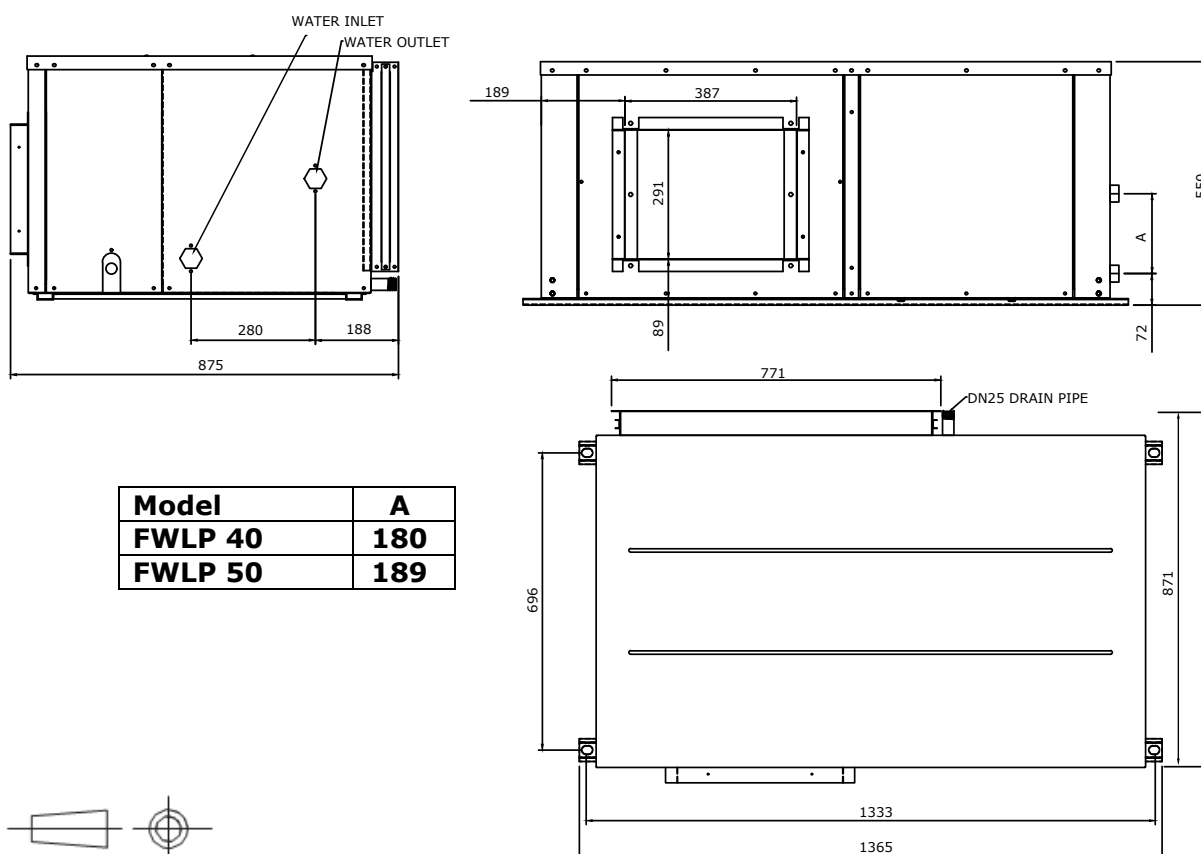

Model	A
FWLP 40	180
FWLP 50	189

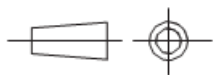

Dimensions in mm

Model : FWLP 70

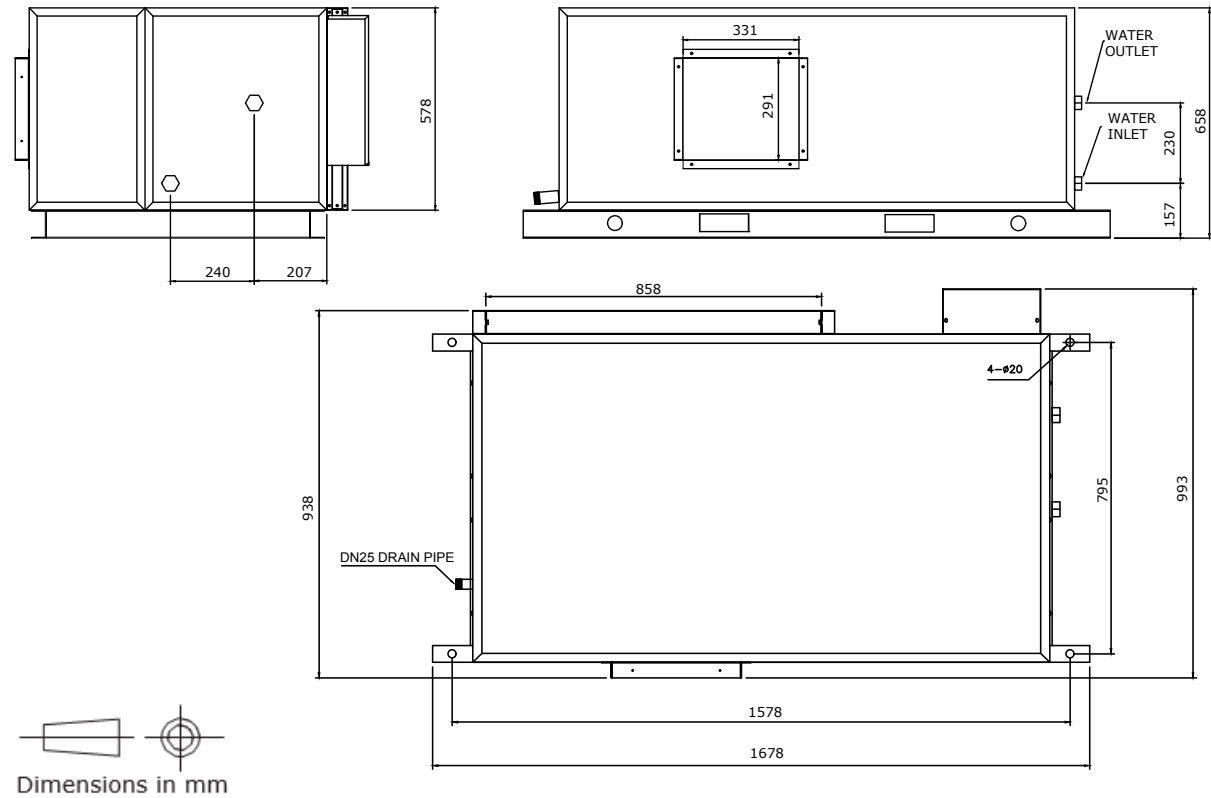

Model : FWLP 100

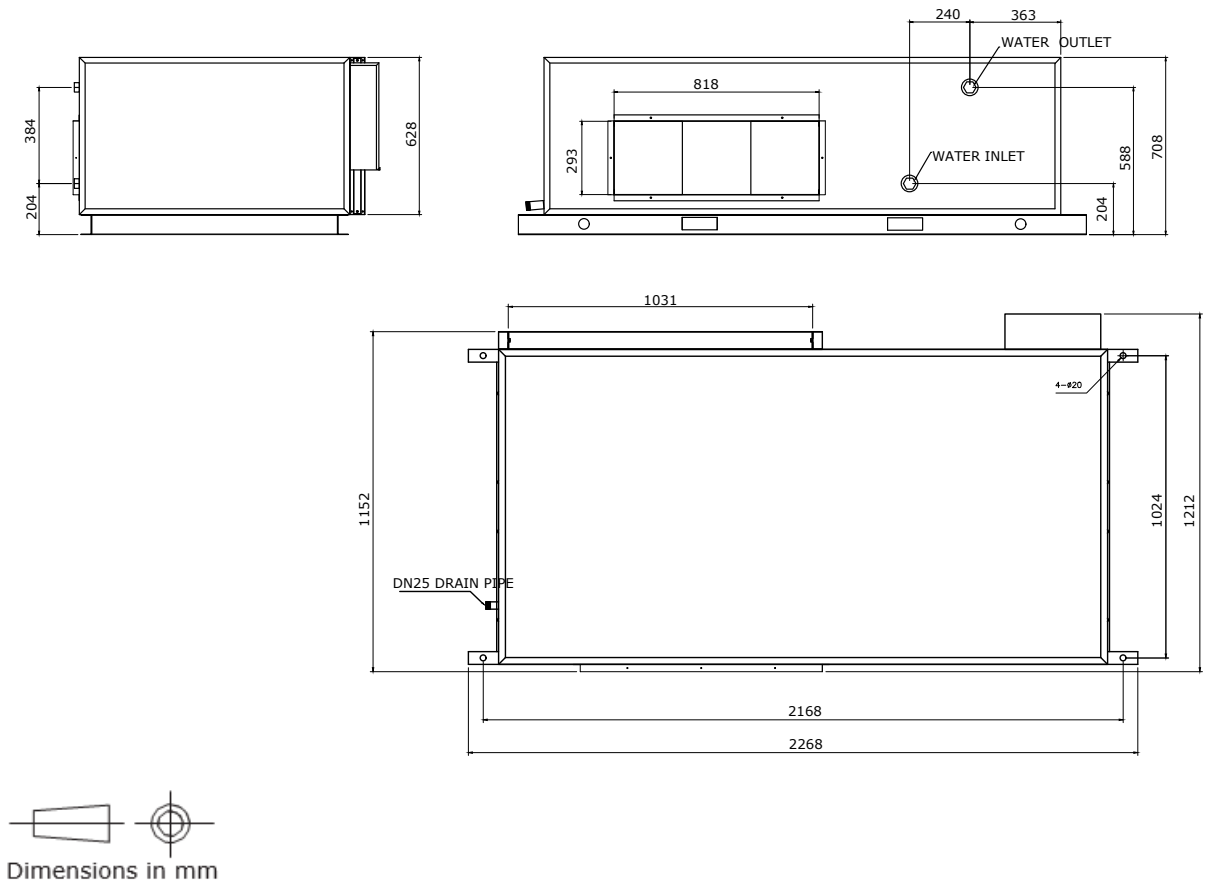

Wiring Diagram

Model : FWSN/FWSD 10 / 15

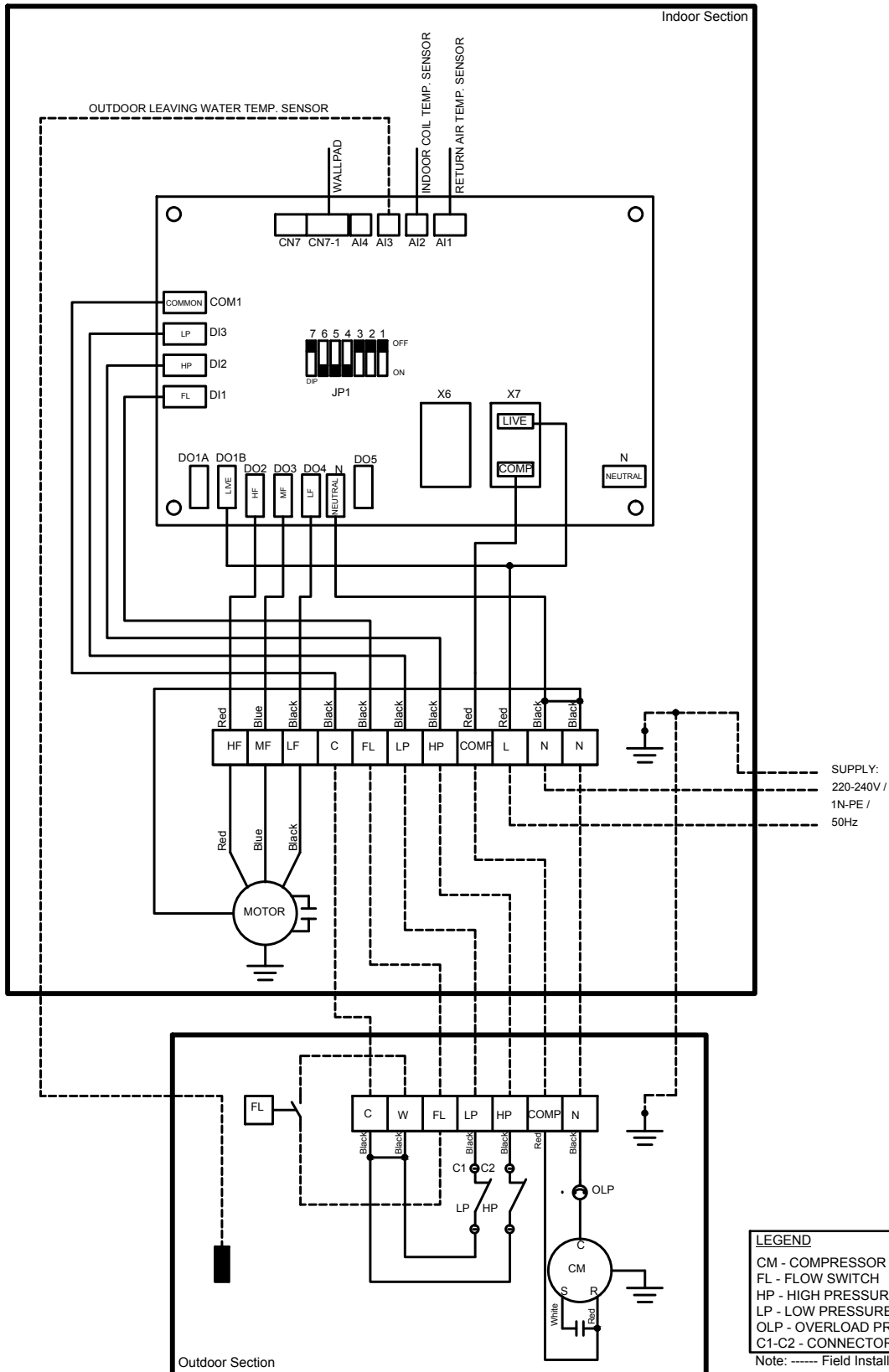

Model : FWSN/FWSD 18 / 20

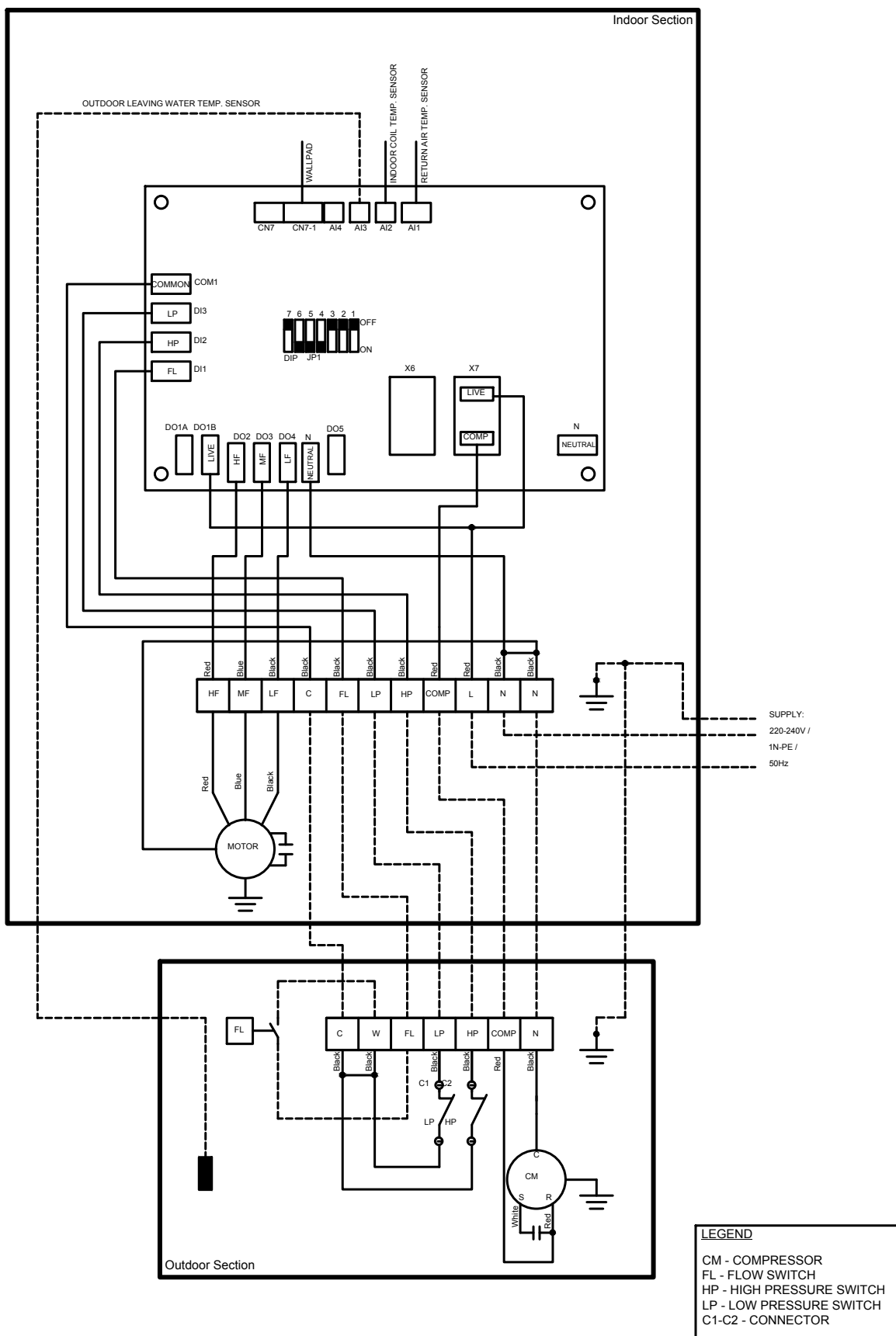

Model : FWSN/FWSD 25 / 30

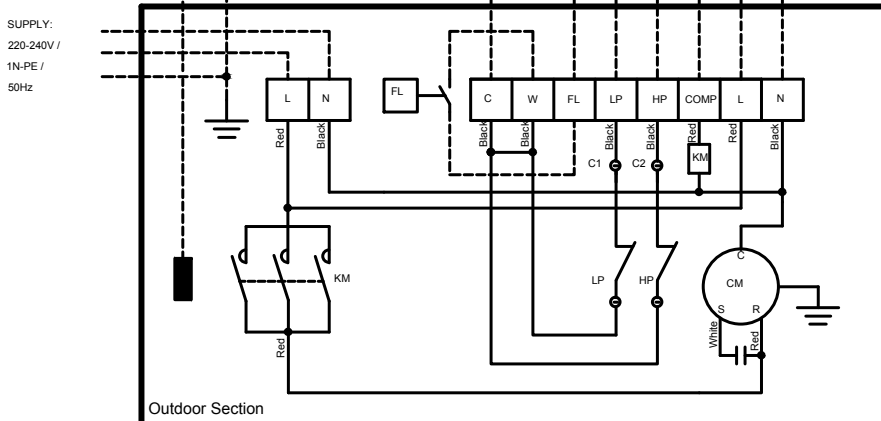
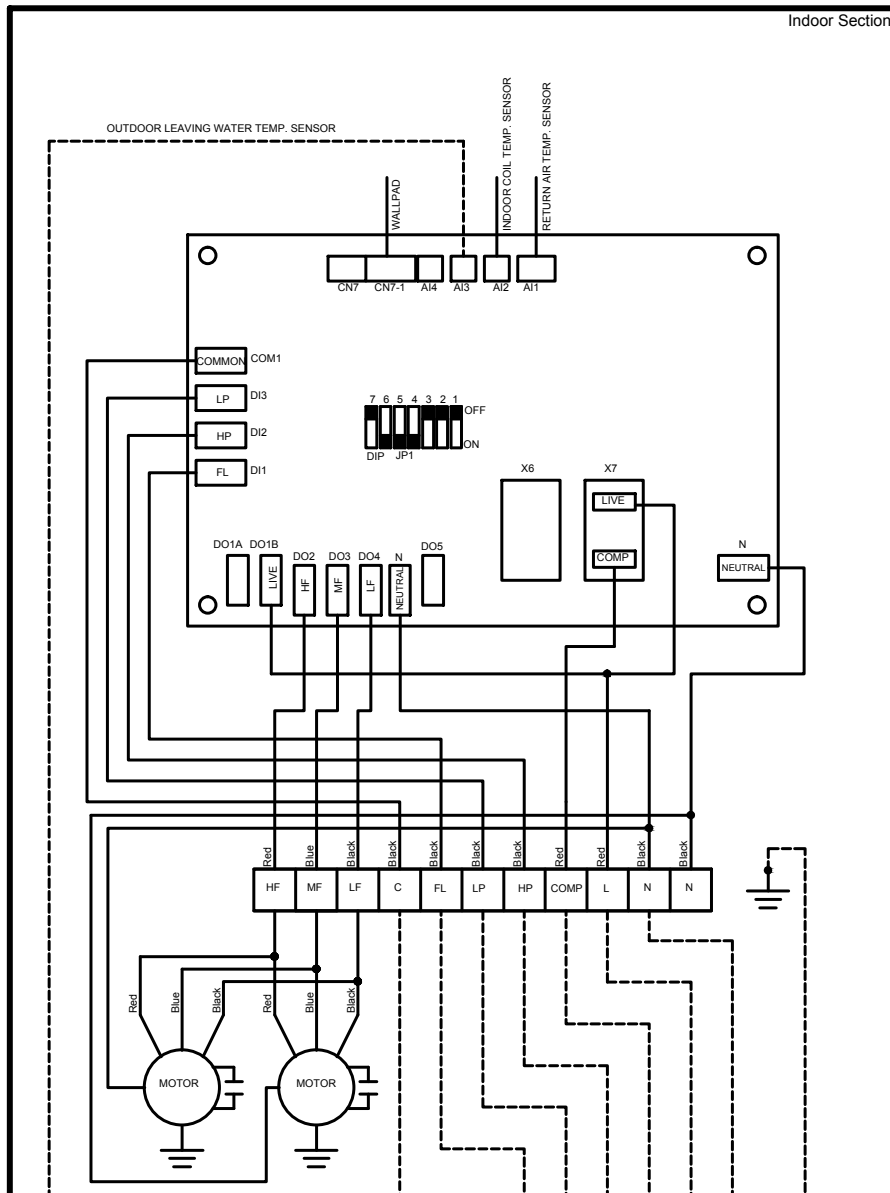

LEGEND

- CM - COMPRESSOR
- KM - AC CONTACTOR
- FL - FLOW SWITCH
- HP - HIGH PRESSURE SWITCH
- LP - LOW PRESSURE SWITCH
- C1-C2 - CONNECTOR

Note: ----- Field Installation

Model : FWSN/FWSD 40 / 50

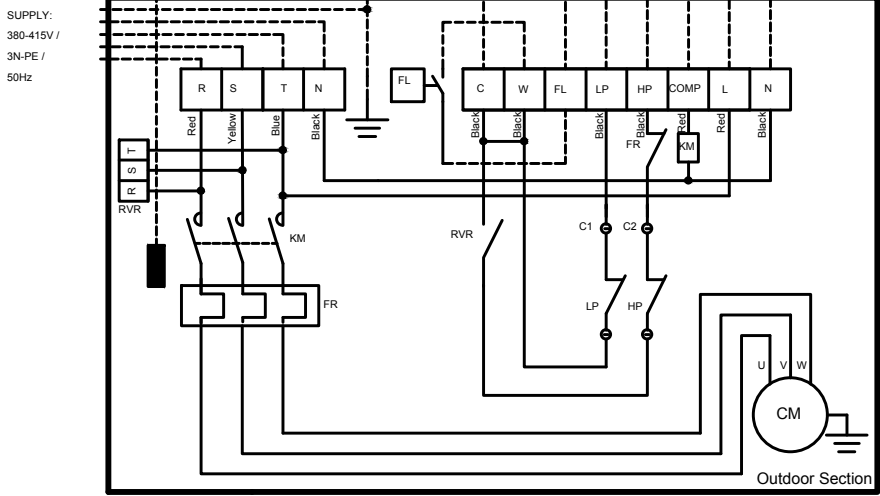
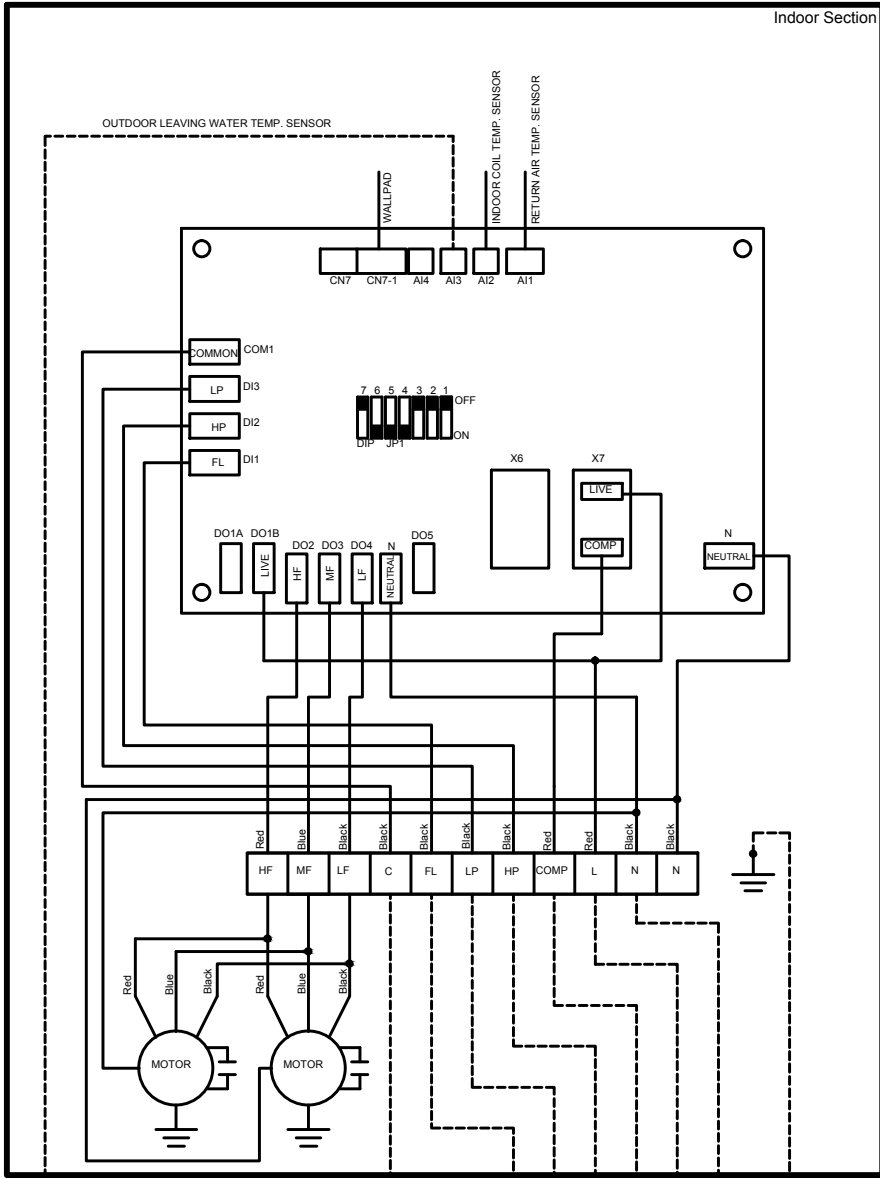

LEGEND

- CM - COMPRESSOR
- KM - AC CONTACTOR
- FR - THERMAL RELAY
- RVR - PHASE PROTECTOR
- FL - FLOW SWITCH
- HP - HIGH PRESSURE SWITCH
- LP - LOW PRESSURE SWITCH
- C1-C2 - CONNECTOR

Note: ----- Field Installation

Model : FWLP 10 / 15

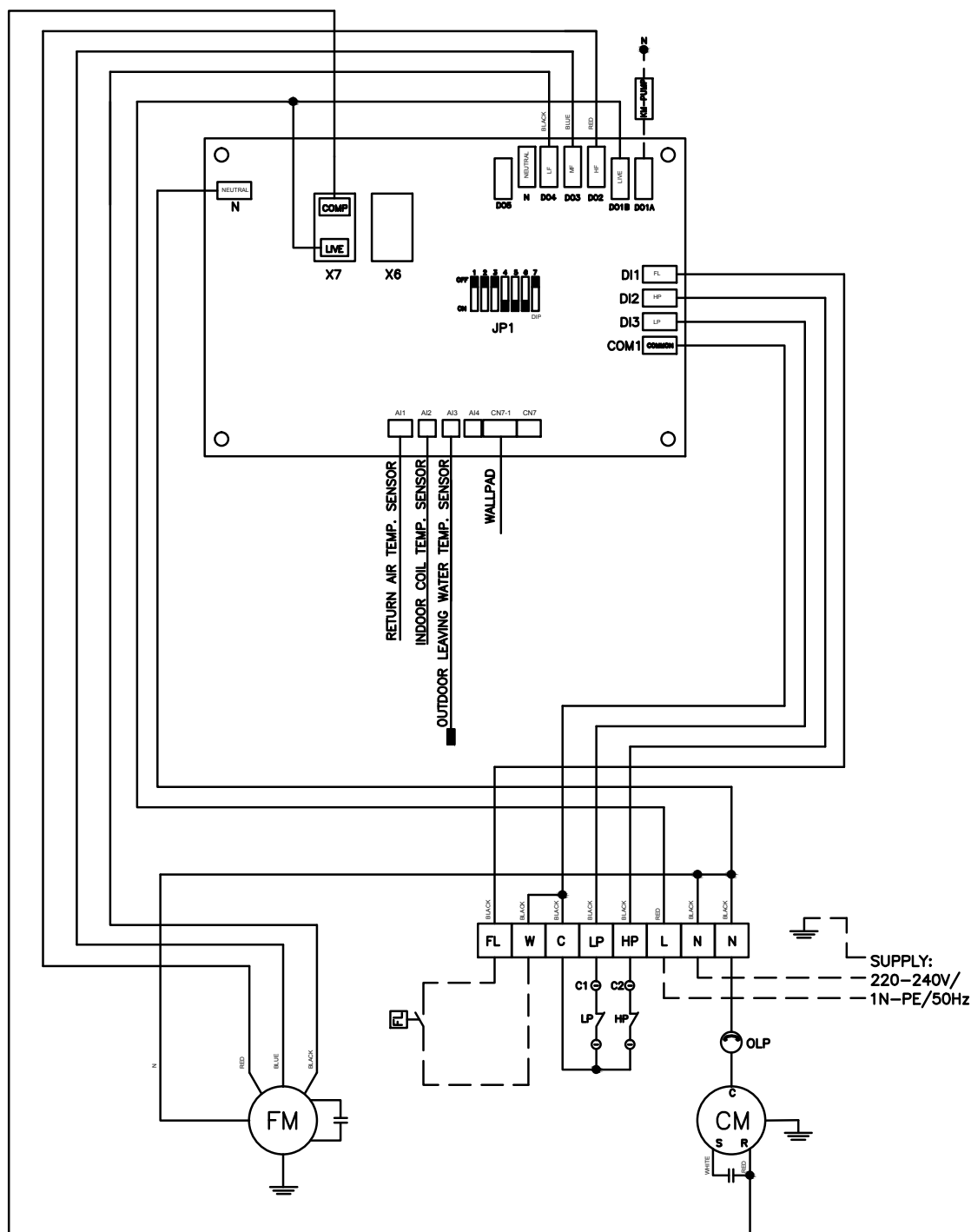

LEGEND	
CM	- COMPRESSOR
FM	- FAN MOTOR
FL	- FLOW SWITCH
OLP	- OVERLOAD PROTECTOR
HP	- HIGH PRESSURE SWITCH
LP	- LOW PRESSURE SWITCH
C1-C2	- CONNECTOR

Note: ----- Field Installation

Model : FWLP 20

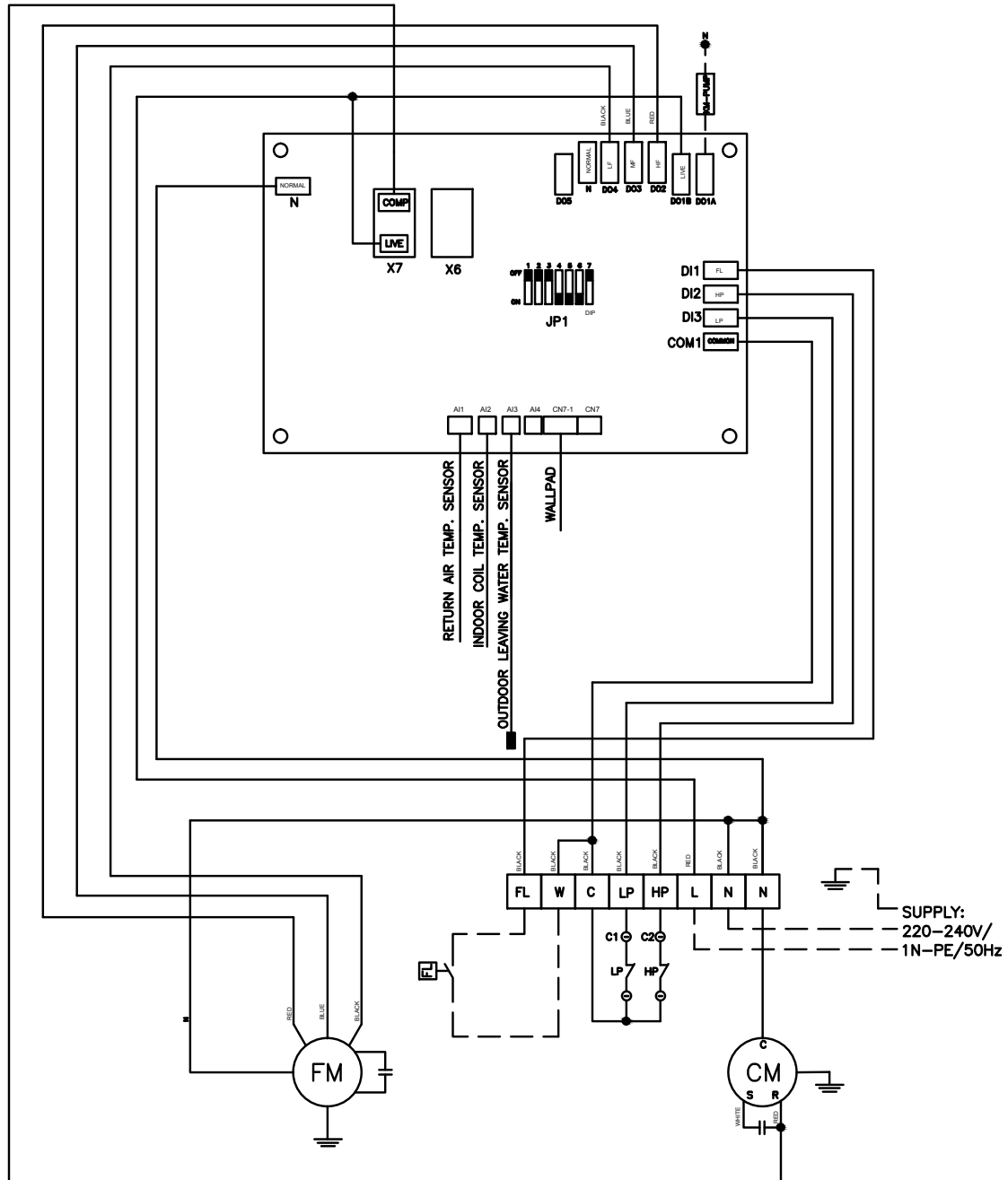

LEGEND
 CM - COMPRESSOR
 FM - FAN MOTOR
 FL - FLOW SWITCH
 HP - HIGH PRESSURE SWITCH
 LP - LOW PRESSURE SWITCH
 C1-C2 - CONNECTOR

Note: ----- Field Installation

Model : FWLP 25 / 30

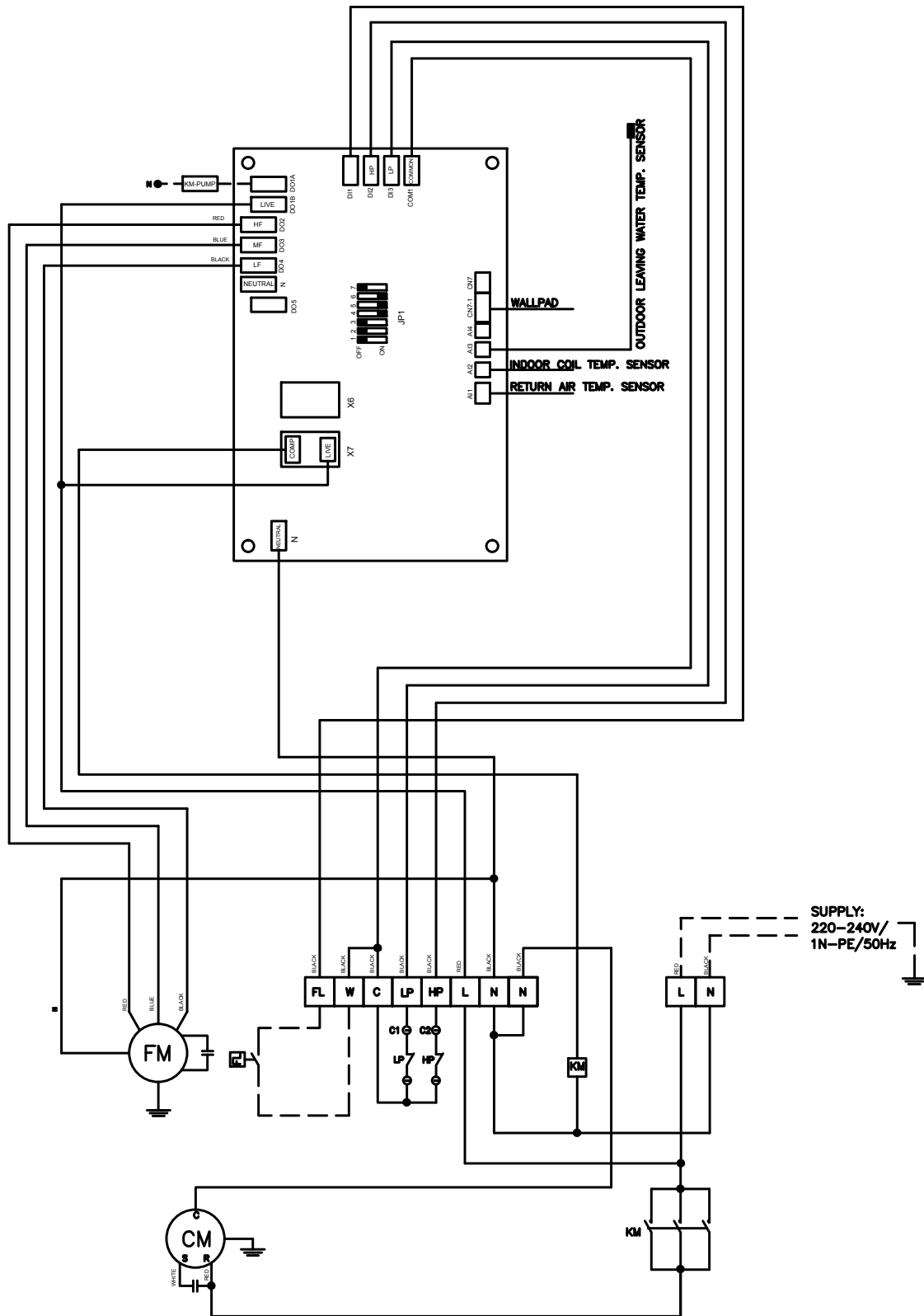

- LEGEND**
- CM - COMPRESSOR
 - FM - FAN MOTOR
 - FL - FLOW SWITCH
 - KM - CONTACTOR
 - HP - HIGH PRESSURE SWITCH
 - LP - LOW PRESSURE SWITCH
 - C1-C2 - CONNECTOR

Note: ----- Field Installation

Model : FWLP 40 / 50

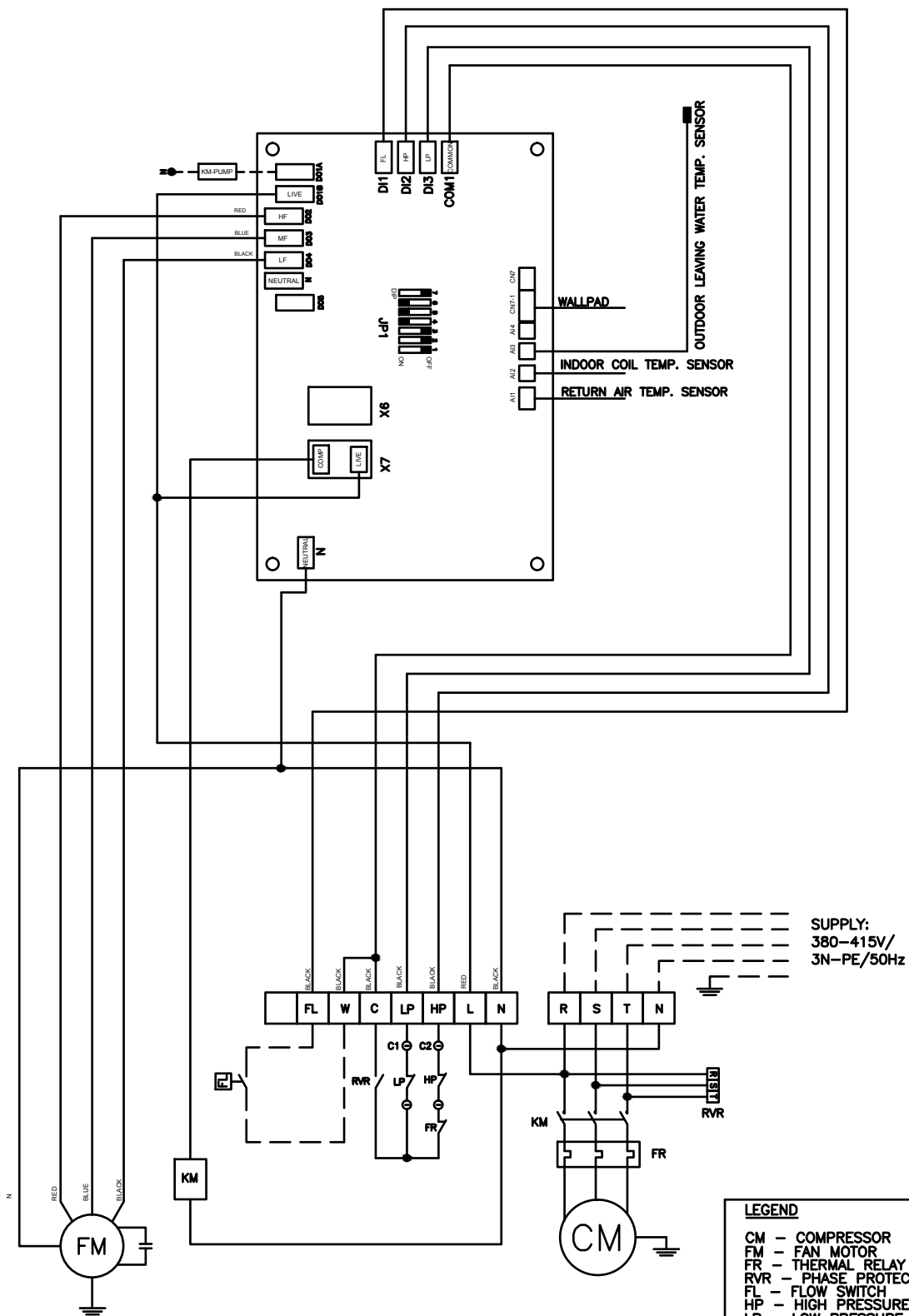

Model : FWLP 70

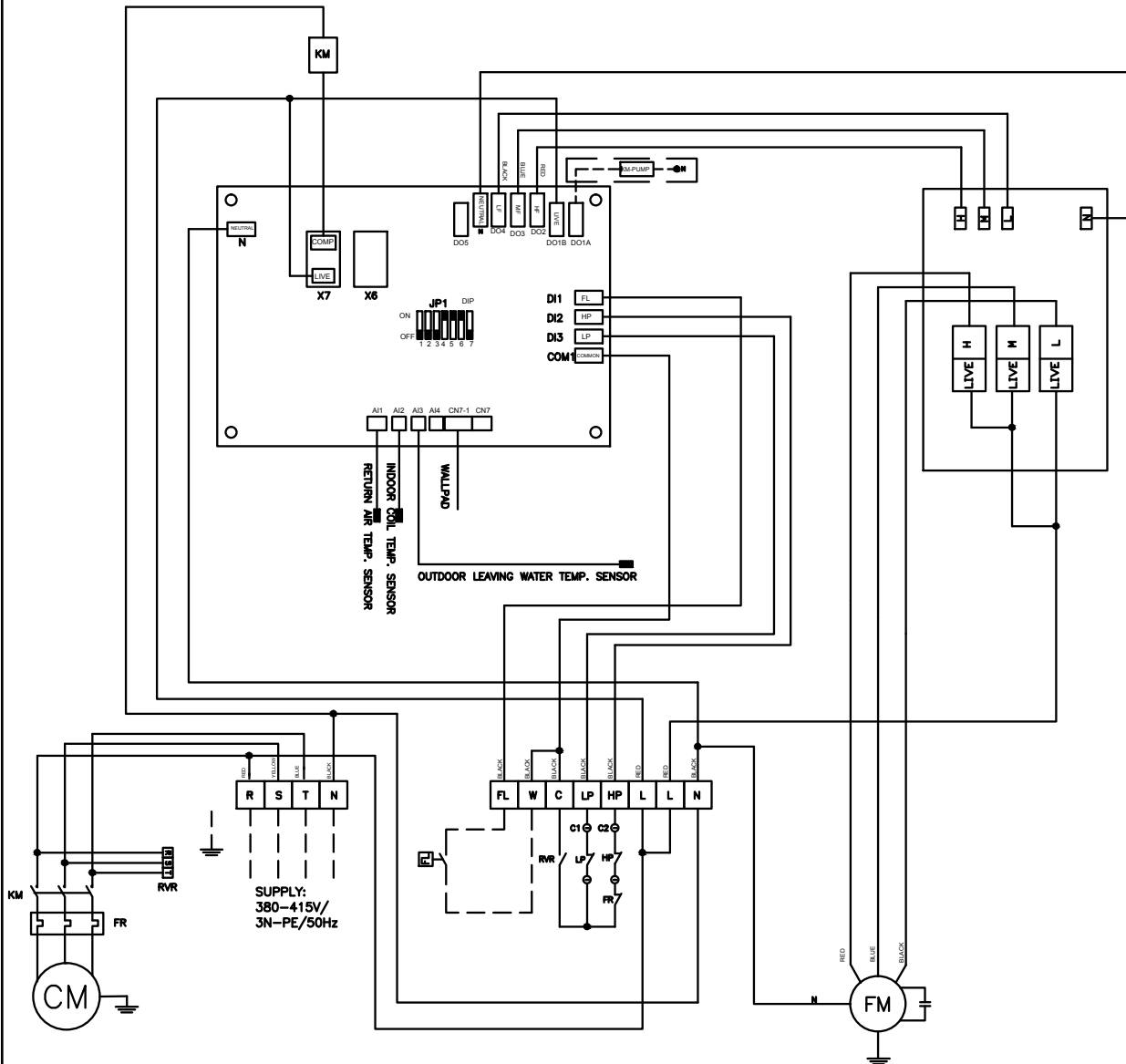

LEGEND

CM - COMPRESSOR
 FM - FAN MOTOR
 FR - THERMAL RELAY
 RVR - PHASE PROTECTOR
 FL - FLOW SWITCH
 HP - HIGH PRESSURE SWITCH
 LP - LOW PRESSURE SWITCH
 KM - CONTACTOR
 C1-C2 - CONNECTOR

Note: ----- Field Installation

FR RANGE SETTING (A)

MODEL	FR
70	10

Model : FWLP 100

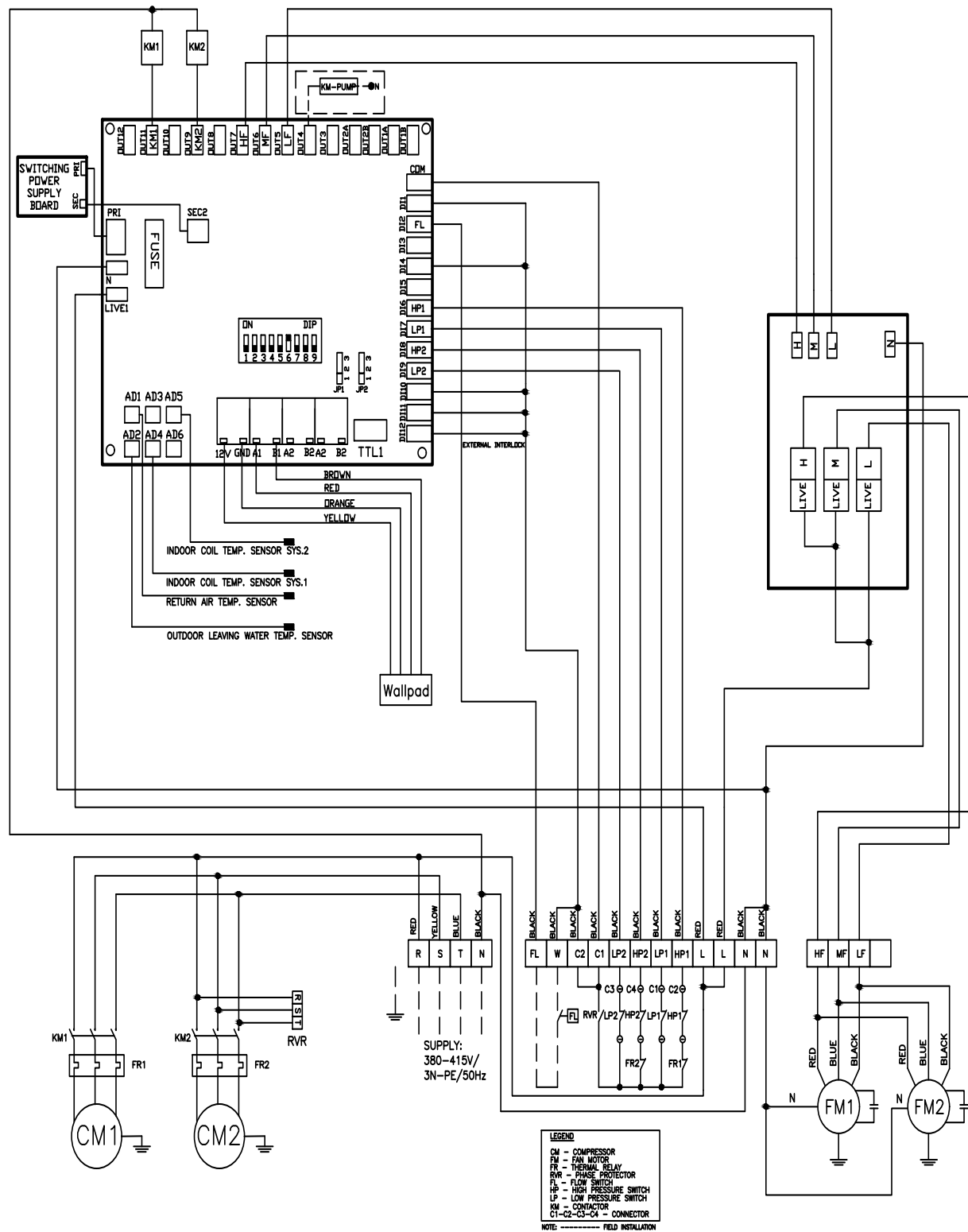

Installation

Unit Location

Unit should be installed by qualified technicians. Installation should adhere to local codes and regulations.

1. Indoor Unit Installation

Carefully plan the installation location with the following considerations:

- Easy distribution of air ducts.
- Space for connection of refrigerant pipes, wirings and water pipes.
- Ceiling/structure is strong enough to support the unit.
- For noise consideration, always install unit away from conditioned area.

Use the hanging rods to hang the unit through the holes provided. Strength of hanging rods must be able to support the total weight of the unit.

During operation of the unit, there will be plenty of condensate water that needs to be discharged. In order to prevent overflow of condensate water, the water must be drained through condensate water pipe. Please ensure a gradient is maintained as shown in the following diagrams.

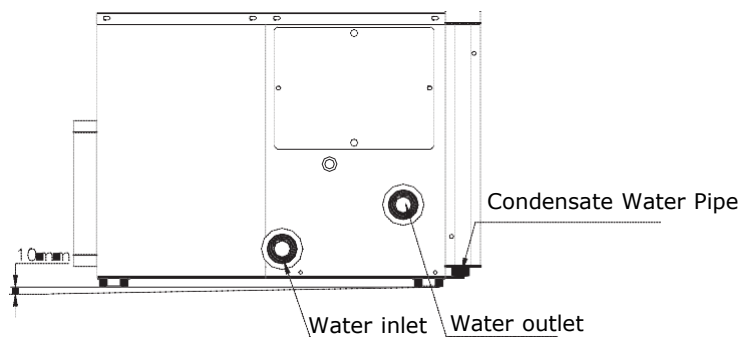
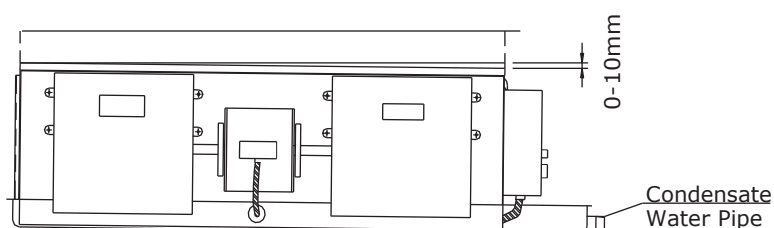

Unit to be installed with gradient

For the installation of returned and supply air ducts please refer to the section on Installation of Air System.

- Design the maintenance door according to the following drawing:

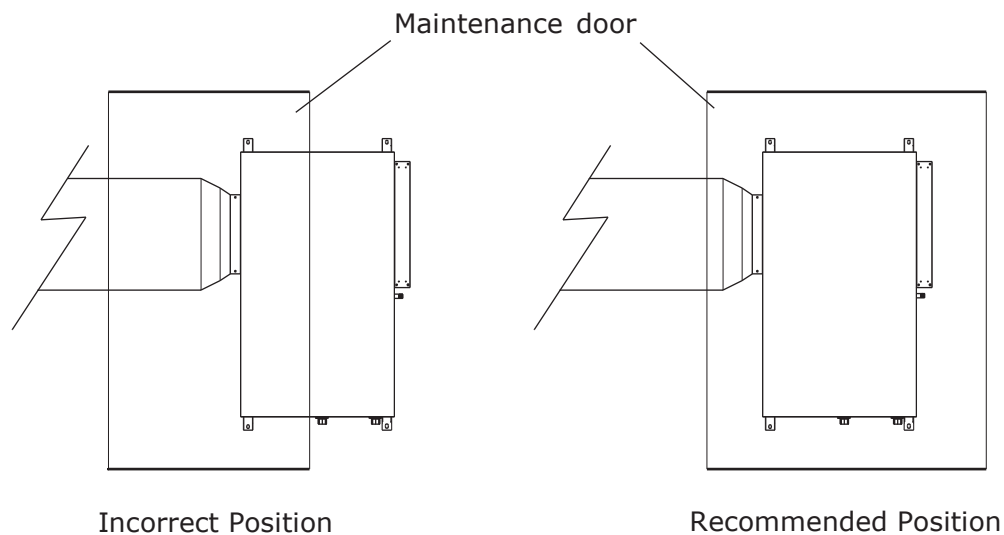

- To reduce noise transmission through hanging rod, it is recommended to install rubber damper or isolator.
- Muffler can be used to reduce noise transmission through air duct if the unit need to be installed near conditioned area.

Condensate drain pipe installation:

- For easy drainage of condensate water, drain pipe must be sloped downward at least at a gradient of 1: 100.
- The drain pipe must have a J-bend.
- Drain pipe that runs under the ceiling or within the conditioned space should be insulated to prevent condensation of water . Choice of insulation material can be PE, PU or other appropriate insulation material.

2. Outdoor Unit Installation

For split type Water Cooled location of installation is flexible. It can be hung below ceiling at balcony, in wash room, utility room, etc. Choice of location should be places that have proper sound barrier and not sensitive to vibration noise. Most importantly, sufficient space should be allocated for ease of servicing and listed in the following are some installation recommendations:

- Sufficient space must be available for water pipes, copper pipes and electrical wires connection.
- Sufficient space has been reserved for service and maintenance as following diagram.
- After installation, checking must be carried out to ensure the hanging and support of unit is installed properly and rigid, level of unit is properly maintained and vibration isolators are installed.

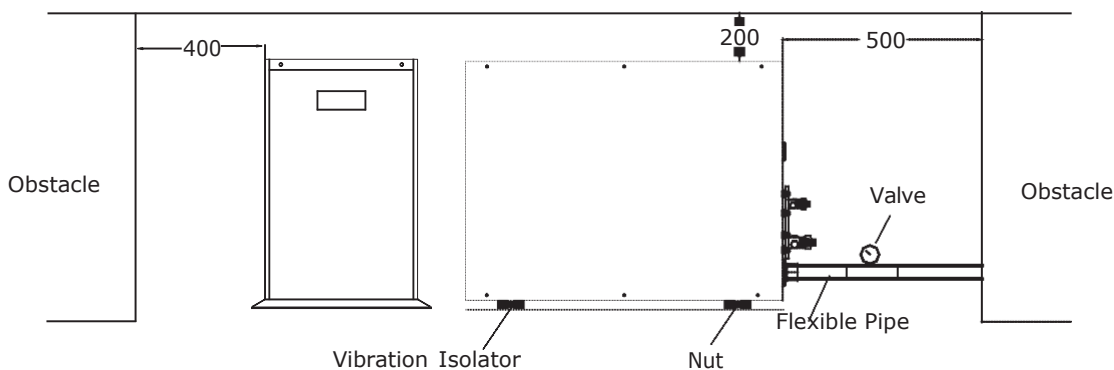

- If the outdoor unit needs to be hung under ceiling, there are 2 methods of installation as shown in the following diagrams. Make sure the hanger provided is strong enough to support the whole weight of the unit (including the water inside the tube when in operation).

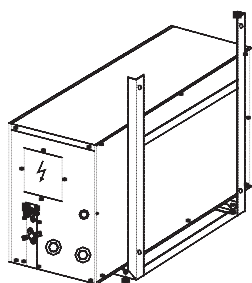

Method A : Using angle iron

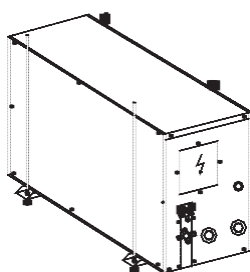

Method B : Using hanger rods

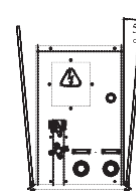

- 8mm dia. hanger rod
- Vibration isolator
- Washer
- Nut

3. Indoor and Outdoor Unit Connection

Ensure cleanliness of the connecting copper pipes for split type Water Source Heat Pump is maintained all the time. Seal both the open ends of copper pipes before brazing or connecting using flare. Make sure that there is no dented pipe and always make use copper bending tools to bend copper pipes. When the height difference of indoor and outdoor unit is more than 5m, install oil trap at every 5m intervals.

A. Outdoor Unit is installed at higher position

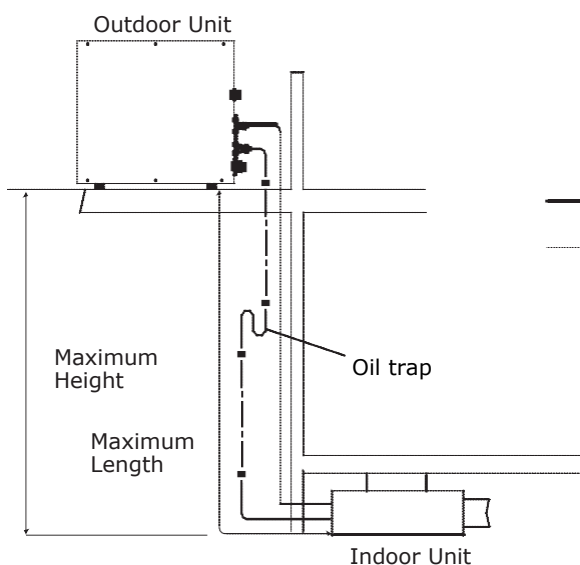

B. Outdoor Unit is installed at lower position

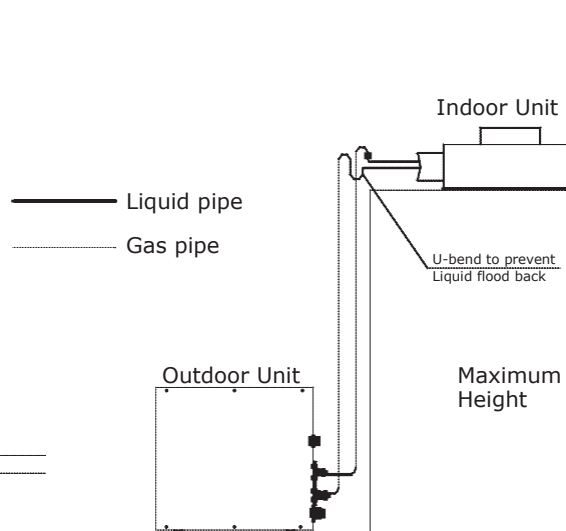

4. Vacuuming and Refrigerant Charging

The packaged or outdoor unit for Water Source Heat Pump are fully charged with refrigerant in the factory. For split type water source heat pump, after the copper pipes are connected and before opening the valves, the indoor pipes need to be vacuumed. It is important that the indoor unit is properly vacuumed to make sure the system is free of dust and moisture.

Note : Vacuum level must be maintained at 130Pa for at least 5mins to check for leakage.

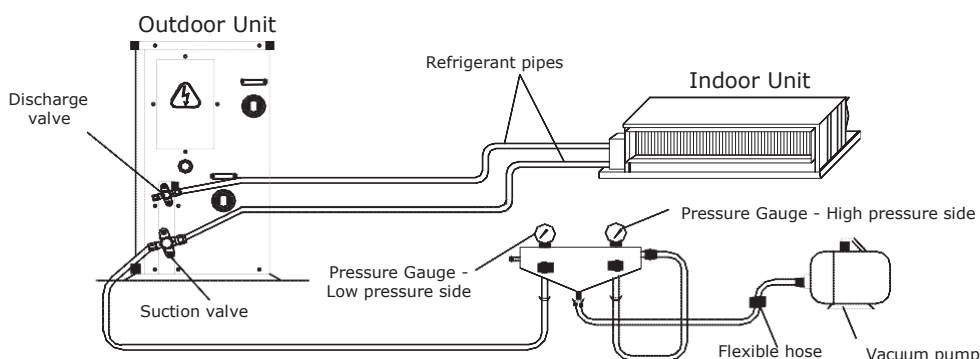

Refrigerant Charge

When the inter-connecting copper pipe length is more than 7m, additional refrigerant should be added according to the following diagram and the amount of refrigerant to refer to the following table:

Model	Additional Refrigerant (kg/m)	Maximum pipe length (m)
FWSD08/10/15/18/20	0.01	15
FWSD25/30	0.03	20
FWSD40/50	0.06	30

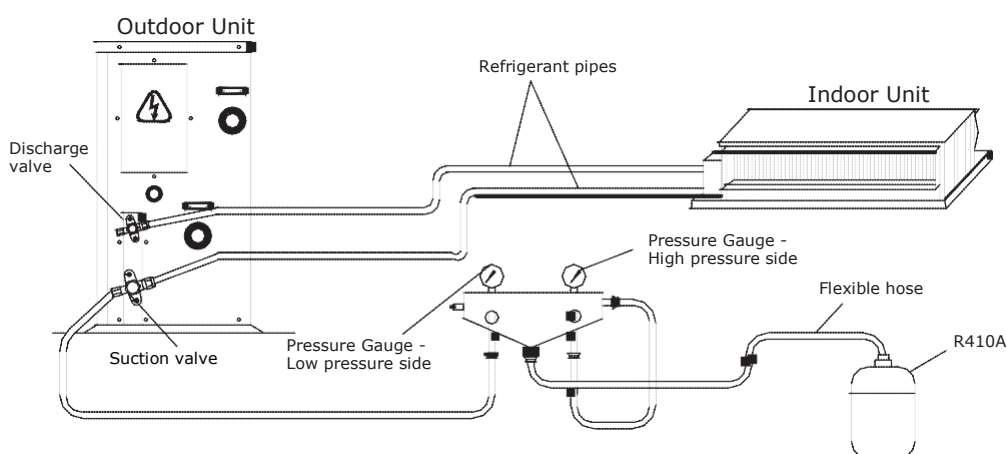

5. Electrical Installation

All wiring must comply with the local electrical regulations and law. The fluctuation of voltage should be within $\pm 10\%$.

Cautions:

- Before connecting the wires, ensure the power supply is according to the requirement.
- Every air-conditioning unit requires independent electricity supply equipped with circuit breakers.
- All units must be properly GROUNDED.
- All wiring connection must be correct and firm.
- Electric wiring must not physically be in contact with refrigerant piping, compressors, motors or other moving parts.

Cautions:

- All electrical wires will be connected at site.
- The wires should be fixed by clips.
- Always refer to the enclosed wire diagram while connecting wires.

Protection Class: I Type

Waterproof Class: IPX4

6. Water System Installation

Water pipe installation should comply with local regulations. To save cost and ensure the good performance of unit, reduce the U-bends and vertical piping. The pipe need not be insulated. Please refer to the following instructions for installation:

The water pump is normally installed between the cooling tower/boiler and unit.

- a. If the water tank is needed, it will be installed at the unit water outlet portion.
- b. To balance the water pressure, use the same distance of the water flow system.
- c. Set a balance valve at every pair of vertical pipes. Set filter at water inlet of each water pump.
- d. Use soft connection for water pipe connection.

Set a valve to adjust the water flow rate to ensure inlet/outlet temp difference 5°C .

Following is the water system diagram.

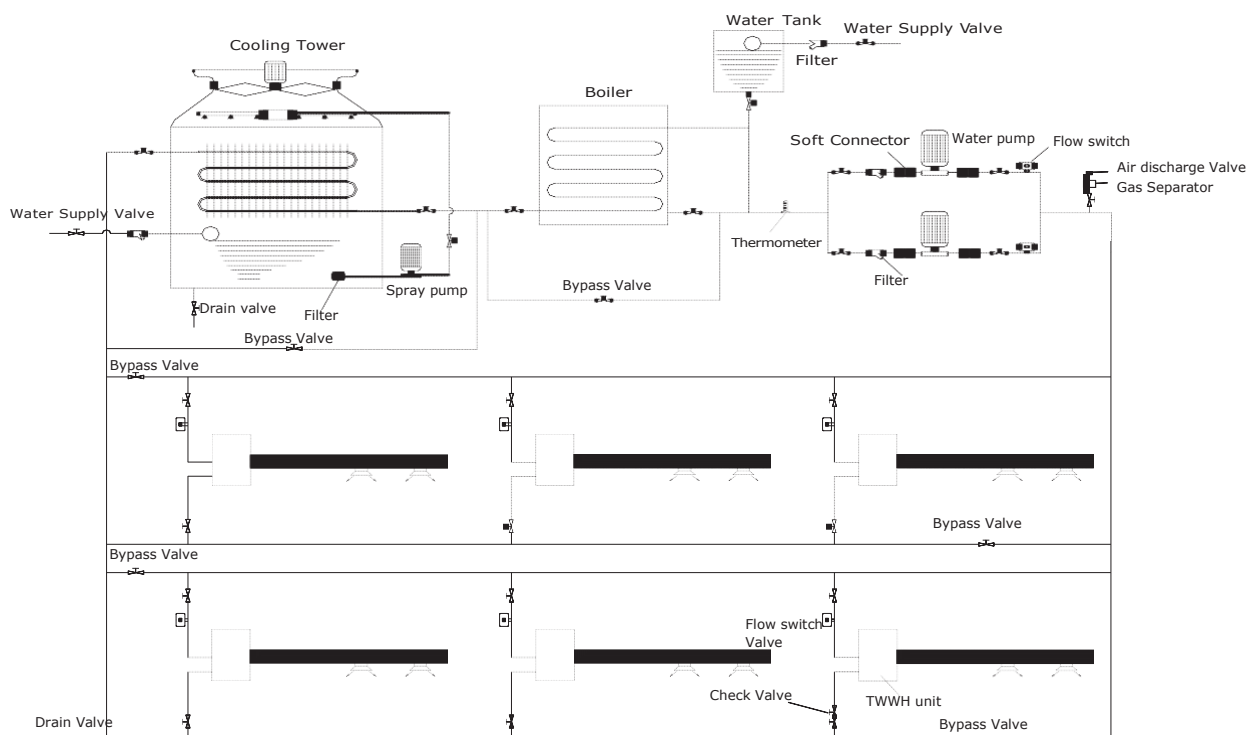

Cooling Tower

The water system must be a total enclosed system. It will be a better choice to use a total enclosed evaporation cooling tower. Refer to the above diagram.

Another type of cooling tower is open type with heat exchanger (normally it is a plate heat exchanger).

Refer to the diagram at right hand.

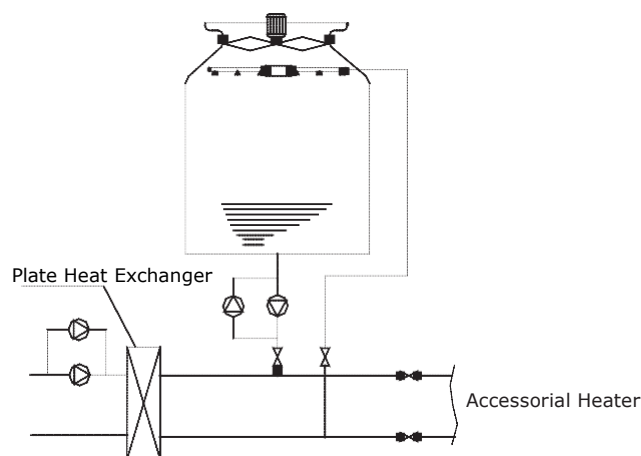

Water Pipe Diameter

Pipe dimension must be properly selected to keep low noise level and water friction. For 50mm pipe, the max water flow speed is 1.2m/s and the min water flow speed is 0.5 m/s. Keeping the water flow speed within the range can minimize the water pump and noise.

Water Pump Requirements:

- Meet the requirements on water flow volume, pump head and power.
- Must have a spare pump with auto switching control to reduce the problems caused by low water flow rate.
- Set an open circuit relay to shut off the pump when there is a problem occurs.

7. Air Ducting Installation

7.1. Installation of Indoor Unit Air Ducting

- There are two types of discharge air-duct, namely rectangular and round ducts.
- Rectangular ducts can be connected to the discharge of the indoor unit directly, refer to the external diagram of the unit to see the dimensions of the discharge.
- Soft connection must be installed between air ducts and indoor unit to ensure the quiet operating.
- A reducer is necessary to connect the round duct to the discharge of the unit.

Each discharge is connected to its independent diffuser by a ducting not exceeding 6 m. The air speed at each diffuser should be similar in order to satisfy the cooling or heating load supply to the room.

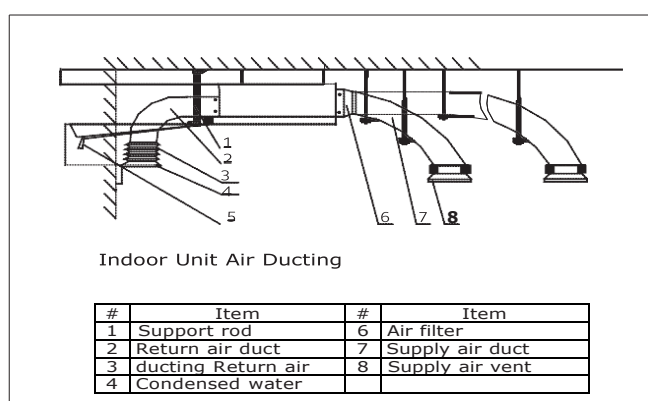

Caution:

When the dimensions of the air duct and that of the discharge of the unit differs a reducer is needed. Precaution must be taken so that the reducer does not block any portion of the air duct and the length of the entire air ducts should assure similar air speed at every diffuser.

To prevent vibration of the air ducts, it is recommended that the return air duct be connected to the unit by soft connection.

7.2. Installation of return air duct

Connect the return air duct to the unit by means of soft connection. Connect the other end of the air duct to the return air grill by means of pleated #8 wire mesh reinforced canvass ducting. This allows adjustment of the height of the return air grill conveniently (refer to return air duct connection diagram).

Caution:

To avoid direct transmission of noise into the room, it is recommended to install the return air duct by the rear end. (Refer to return air duct connection diagram) some models are equipped with rear return air plenum.

Insulation of Air Duct

Both discharged and return air ducts must be insulated to reduce capacity loss as well as prevent sweating.

Others

All discharge and return air ducts must be firmly fixed to the ceiling by means of steel frames; air duct joints must be properly sealed by sealant. To ease repair and maintenance, the return air duct must be kept away from the wall by at least 150 mm.

Servicing and Maintenance

Test Run and Operation

Firstly, the whole water system must be cleaned and tested for leakage. Shut off all the valves except the air discharge valve while cleaning. After cleaning, open the water discharge valve to discharge the dirty water. Repeat this for 2-3 times till the water is cleaned. Open all the valves and start the water pump, cooling tower and boiler.

Secondly, while running the unit, make sure the water temperature is 30°C (Cooling). The temperature difference between water inlet and outlet should be 5~6°C while cooling and 3.5~4.5°C while heating. Check for any abnormal vibration, noise, water leakage or Freon leakage.

Regular Maintenance

To ensure stable operation, please check the unit condition regularly, such as the electric circuit, temp difference between water inlet and outlet, filter, Freon amount etc. Check the water pump, cooling tower or boiler at least once a day. Check the circulation water quality regularly every week. Make sure the water PH value is between 7.8~8.5 to prevent the water pipe and boiler from corrosion.

- Air Filter

The filter must be cleaned regularly and the frequency of cleaning is to be determined by the degree of pollution of the environment of application. When washing the filter, first tap it gently to remove larger particle, and then rinse the filter in detergent and warm water. The filter must be dried before it is used. The filter is recommended to be installed before the air grill or the indoor coil.

- Motor

It is not necessary to lubricate the motor for service and maintenance.

- Heat Exchanger

After in use for a while, the surface of the coil may collect dust, dirt or other alien substances. It is recommended then to clean the fins of the coil using a nylon brush or vacuum cleaner. If compressed air is available, it can be used to clean the coil by direct blowing. However care must be taken not to damage the fins.

- Drain Pipe

Check the drain pipe regularly to prevent blockage by alien substances.

Warning

Do not use oxygen, acetylene, poisonous gas or any other gas that will cause explosion under high temperature and pressure for leak checking. Instead, use Nitrogen or R410A for air leakage test.

Troubleshooting

Troubleshooting Guide

Circuit	Pressure		Cause
	Status		
	Over low	Over high	
High pressure side		•	1. Overcharge of refrigerant. 2. The refrigerant pipe is not vacuum.
Low Pressure Side		•	3. Water temperature is too high. 4. Low water flow (Cooling). 5. The filter is blocked or too dirty.
High pressure side	•		1. Incomplete compression or no compression (compressor problem).
Low Pressure Side		•	2. Four way valve leaking.
High pressure side	•		1. Lack of refrigerant. 2. Leakage of refrigerant.
Low Pressure Side	•		3. Water temp is too low. 4. Low water flow. 5. The filter is blocked or too dirty(Cooling)

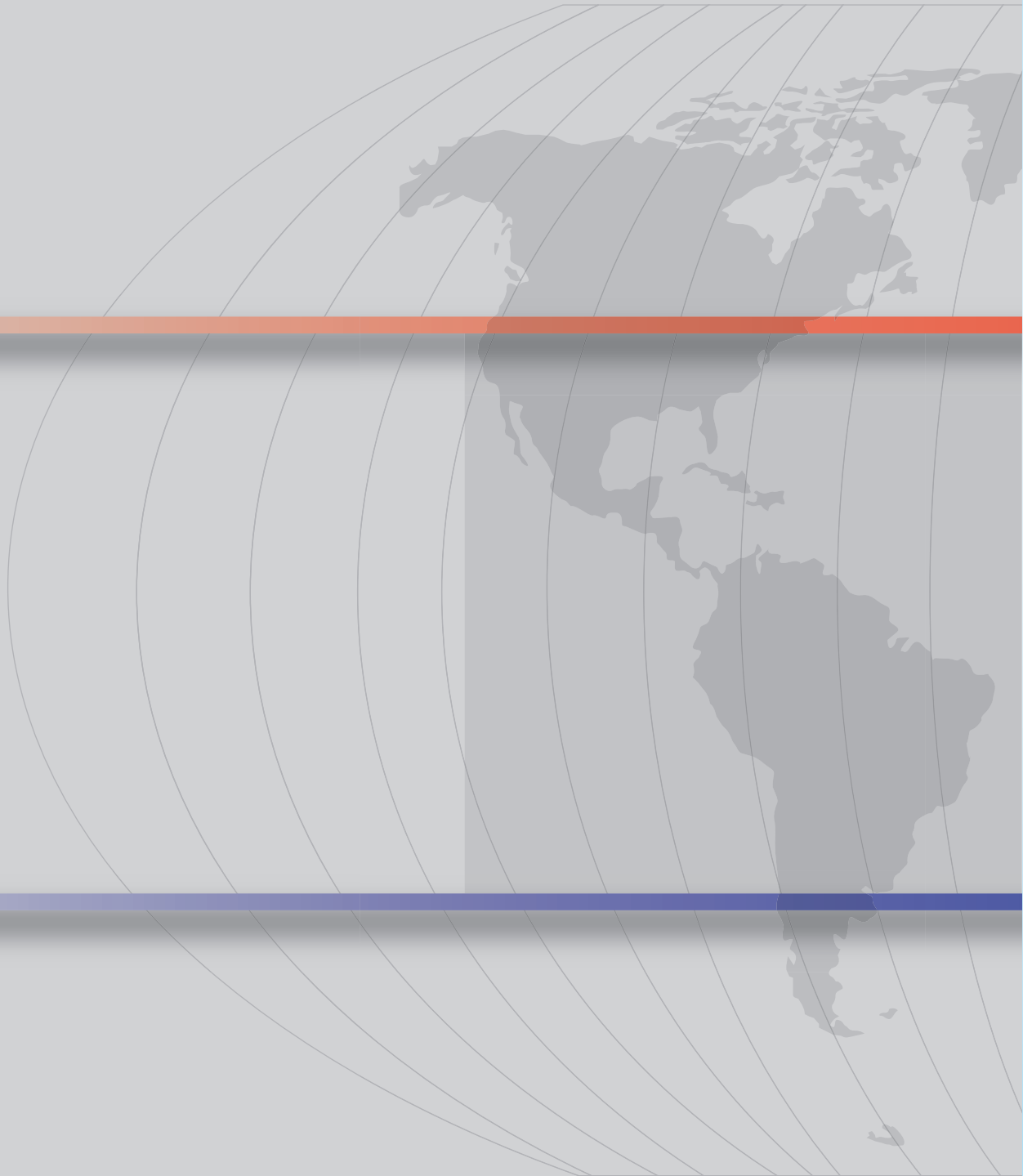

A member of FRIMEC International Group