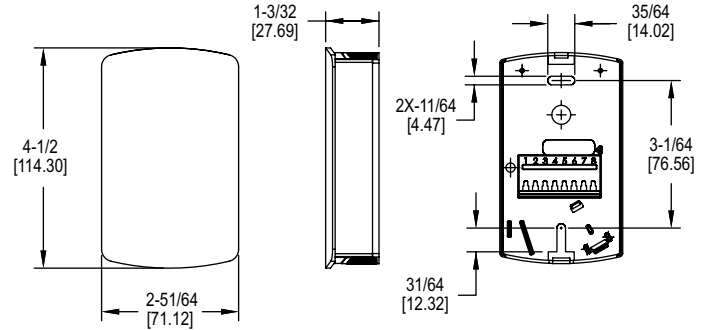

CARBON DIOXIDE TRANSMITTER

NDIR CO₂ Sensor, Universal Output, Passive Temperature

CALIBRATION SERVICES AVAILABLE

The **Model CDSN Carbon Dioxide Transmitter** accurately monitors the CO₂ concentration and temperature in schools, office buildings, and other indoor environments to help achieve LEED® certification and energy savings. In order to achieve a higher level of accuracy, the Model CDSN includes digital barometric pressure adjustment. The CO₂ universal output allows users to select the transmitter output to be 4-20 mA, 0-5 VDC, or 0-10 VDC to work with virtually any building management controller. In addition, the housing security feature reduces the likelihood of physical tampering.

BENEFITS/FEATURES

- Minimize inventory and save time by combining CO₂ and temperature measurement, as well as DIP switch selectable current/voltage outputs
- Integral passive temperature reduces the number of devices mounted in the space
- Requires minimal maintenance with Automatic Baseline Correction (ABC) to account for sensor drift
- Reduce operation costs using a low energy, reliable, and repeatable CO₂ sensor
- Simplify installation with backplate electrical connections

APPLICATIONS

- Demand control ventilation in schools
- Indoor air quality monitoring in office buildings

MODEL CHART

Model	Description
CDSN	Carbon dioxide transmitter

SPECIFICATIONS

Sensor: NDIR, 15 year life expectancy.

Range: 0 to 2000 PPM.

Accuracy: ±40 PPM +3% of reading*.

Response Time: < 120 s (τ₉₀).

Warm Up Time: < 2 minutes operational; 10 minutes max accuracy.

Temperature Sensor Accuracy: ±1°C @ 25°C**.

Temperature Limits: Operating: 32 to 122°F (0 to 50°C); Storage: -22 to 158°F (-30 to 70°C).

Humidity Limits: 0 to 85%, non-condensing.

Power Requirements: 24 VAC/VDC ± 20%, 50/60 Hz.

Output Signal: Field selectable; Current: 4-20 mA or 0-20 mA; Voltage: 0-5 V, 1-5 V, 0-10 V, or 2-10 V.

Electrical Connection: Screw terminals.

Enclosure Material: ABS.

Enclosure Rating: NEMA 1 (IP30).

Agency Approvals: CE.

*The specified CO₂ accuracy is only guaranteed after three weeks of continuous operation in environments which are intermittently occupied.

**Included passive sensor: Sensor A - 10K Ω type 3 NTC thermistor; Sensor B - 10K Ω type 2 NTC thermistor; Sensor F - 20K Ω NTC thermistor.