

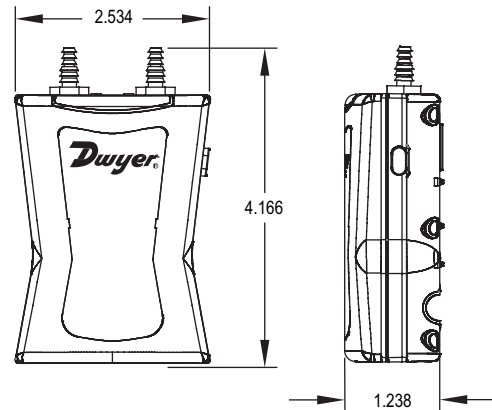

Series DP3 Wireless Differential Pressure Module

Specifications - Installation and Operating Instructions



The **Series DP3 Wireless Differential Pressure Module** is a compact, highly accurate, auto-ranging differential pressure module ideal for low flow applications. The Series DP3 is used in conjunction with the Dwyer Mobile Meter® application software to view pressure drop across filters, static pressure in ducts, and velocity pressures from pitot tubes or air flow stations.

The Series DP3 includes a differential pressure sensor with positive and negative ports for differential and static pressure readings, a LED indicator, and a rechargeable lithium-ion battery; which can be charged via Mini-USB. The Series DP3 Utilizes Bluetooth® Low Energy (BLE) to communicate wirelessly in real-time with the Dwyer Mobile Meter® application software.

NOTICE

This device complies with Industry Canada license-exempt RSS standard(s). Operation is subject to the following two conditions:

(1) This device may not cause harmful interference, and (2) this device must accept any interference received, including interference that may cause undesired operation.

Cet appareil est conforme à des règlements d'Industrie Canada exempts de licence standard RSS (s). Son fonctionnement est soumis aux deux conditions suivantes: (1) Ce dispositif ne doit pas causer d'interférences nuisibles, et (2) cet appareil doit accepter toute interférence reçue, y compris les interférences pouvant entraîner un fonctionnement indésirable.

This Class B digital apparatus complies with Canadian ICES-003.

Cet appareil numérique de la classe B est conforme à la norme NMB-003 du Canada.

FEATURES/BENEFITS

- Auto-ranging technology maintains optimal performance down to 0.1" H₂O
- LED indicator displays module status, connection, charging and logging to the user
- Over-the-air updates ensure the module has the latest firmware
- Unit can be mounted on both the pitot and velocity grid
- Rechargeable battery allows for a 10 hour battery life
- One button design allows for easy operation and simple logging
- Rugged case allows for a 10' drop without compromising functionality
- Automatically corrects pressure reading depending on the inclination of the module

APPLICATIONS

- Non-corrosive dry gases
- Building commissioning
- Building HVAC test and balance
- Industrial process verification
- Instrumentation validation

SPECIFICATIONS

Service: Non-corrosive dry gases.

Wetted Materials: Zinc plated brass; Silicon.

Accuracy: ±0.5% FS span @ 25°C (includes non linearity, hysteresis, and non repeatability)*.

Pressure Limits: ±10 in w.c. (±2.5 kPa) .

Temperature Limits: Operating: -4 to 140°F (-20 to 60°C); Storage: -40 to 185°F (-40 to 85°C).

Power Requirements: 3.7 V lithium ion battery, user rechargeable; Wireless distance: 50' (15 m).

Weight: 3.3 oz (93.55 g).

Electrical Connections: Female mini-USB.

Hose Connections: Two barbed connections for use with 1/8" (3.18 mm) or 3/16" (4.76 mm) ID tubing.

Approvals: CE, FCC.

*Pressure sensor capable of ±0.1% FS span @ 25°C.

NOTICE

If desired, the DP3 can be operated with USB powered cables less than 3 m in length when connected to the charger or PC.

CHARGING BATTERY

NOTICE

It is required before the initial use of the module to fully charge the battery for 12 hours.

When the charge of the battery is almost used up, the LED on the module of the wireless probe will turn solid red. There is approximately 5 minutes of battery life left at this point. If the module is not already paired to the base unit, it will not pair while in low battery condition.

- Step 1: Plug the mini-USB connector end of the cable into the bottom of the module.
- Step 2: Plug the USB connector end of the cable into the port on the charger or PC (LED on the charger and the module should both light up).
- Step 3: The LED on the module will turn off when fully charged.
- Step 4: Remove USB cable from the module and the charger or PC.

WARNING

Lithium ion batteries are very volatile and can cause a fire if punctured or severely damaged. Only use a Dwyer Instruments, Inc. approved charging device in a well ventilated area away from any flammable materials or gases. Do not incinerate the battery. Only charge between 32 to 113°F (0 to 45°C).

CONNECTING THE DP3

For the latest instructions, please refer to the “Help” button in the Options menu in the Mobile Meter® app.

1. Verify that the UHH4 or newer universal handheld device, or a smart device with the Dwyer Mobile Meter® app has Bluetooth® technology turned on. Open the Mobile Meter® app by clicking on the icon.
2. Press “Without Bridge”.
3. The next screen will display a message that reads “Searching For Probes”. When the DP3 is turned on and discovered by Mobile Meter® the name of the probe will appear on the screen. Click the checkbox next to the desired probe.
4. Use the back button or navigation arrow to go back to the Probes List page.

NOTICE If a module does not appear, power the module down, then power it back on.

LED INDICATER		
State	Color	Timing
Battery is Charging	Green	Solid On
Low Battery	Red	Solid On
Low Power State	All Off	Solid Off
Probe Initializing	Amber	Blinking (mostly on with a short time off)
Waiting to Communicate with Handheld	Amber	Blinking (mostly off with a short time on)
Communicating with Handheld	Green	Blinking

MAINTENANCE/REPAIR

Upon final installation of the Series DP3, no routine maintenance is required. The Series DP3 is not field serviceable and is not possible to repair the unit. Field repair should not be attempted and may void warranty.



This symbol indicates waste electrical products should not be disposed of with household waste. Please recycle where facilities exist. Check with your Local Authority or retailer for recycling advice.

WARRANTY/RETURN

Refer to “Terms and Conditions of Sale” in our catalog and on our website. Contact customer service to receive a Return Goods Authorization number before shipping the product back for repair. Be sure to include a brief description of the problem plus any additional application notes.

Bluetooth® is a registered trademark of Bluetooth SIG, Inc.