

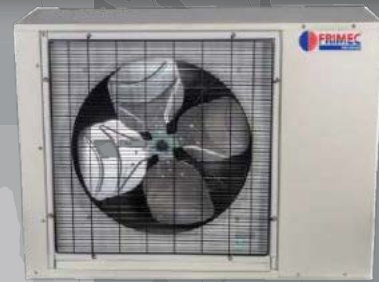

# AIR-COOLED SPLIT DUCTED (R410A SERIES)

Models: FASN080-750  
FASD080-150



---

# Contents

---

Product Nomenclature .....	2
Features.....	3
Engineering Specifications .....	4
General Data.....	4
Electrical Data.....	8
Operating Range.....	10
System Schematic Diagram.....	11
Controller Features and Algorithm.....	16
Fan Performance Curve .....	30
Dimensions.....	39
Wiring Diagrams.....	45
Installations.....	55
Servicing and Maintenance .....	61
Troubleshooting.....	62

# Product Nomenclature

## Air-Cooled Ducted Indoor Unit

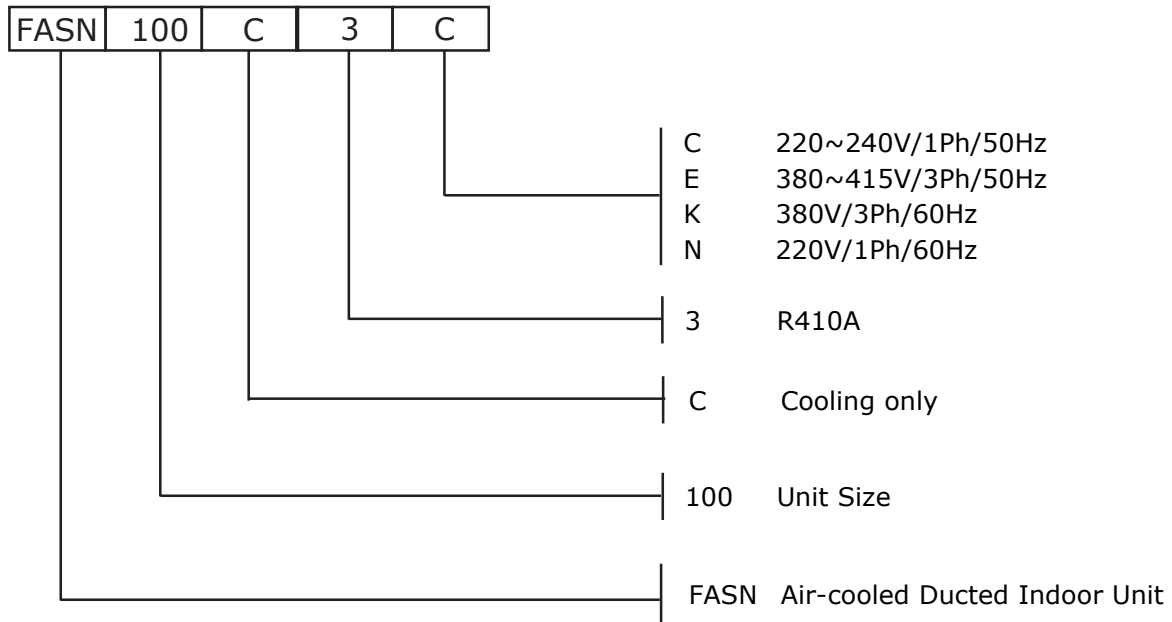

## Air-Cooled Ducted Outdoor Unit

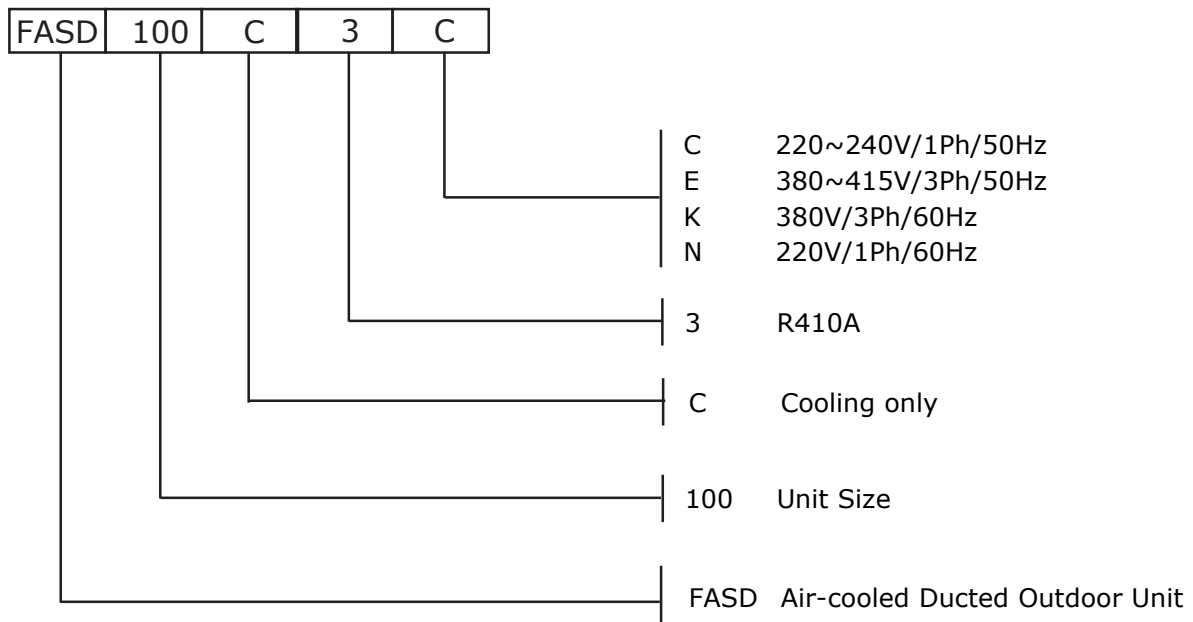

---

## Features

---

### **Wide Range of Product**

Comprises various models with wide cooling capacity to cater for various needs in residential, commercial and industrial application.

### **Multi Circuit Design**

Part load capability offers continuous comfort, greater savings and provides highly flexible solutions for physical constraints at site. It also prolongs lifespan of compressors and reduces big electrical surges.

### **Low Noise**

The outdoor units are using scroll compressors that have been proven to have superior performance and quiet operation. Statically and dynamically balanced fan blowers mounted in acoustically and thermally insulated casings provide excellent and quiet operation. The indoor units for larger capacity and air flow requirement are built with double skin panels made of powder coated steel (outer) and galvanized steel (inner) injected with high pressure PU foam.

### **Flexible Air Thrown**

Convertible discharge air direction at outdoor unit have make it versatile. (Applicable for size 100,125, and 150 only).

### **Intelligent Control (Optional)**

All the features can be easily set and changed through microcomputer-controlled LCD or LED controller. It ensures comfortable cooling is delivered to the user with press of a button and hassle free.

### **Simple Installation**

Compact and light weight design of the units enable easy installation and space saving.

# Engineering Specifications

## General Data - Air-Cooled Split Ducted R410A (50Hz)

Model	Indoor Unit	FASN	80	100	125	150	200	250	300	
	Outdoor Unit	FASD	80	100	125	150	100x2	125x2	150x2	
Total Cooling Capacity		kW	23.4	29.3	36.6	44.0	58.6	73.3	87.9	
		Btu/h	80,000	100,000	125,000	150,000	200,000	250,000	300,000	
Indoor Unit	Type		Single Skin				Double Skin			
	Dimension	Width	mm	1,431	1,731	1,872	1,872	2,248	2,241	2,152
		Length	mm	940	940	1,140	1,140	1,297	1,347	1,547
		Height	mm	441	441	700	700	780	1,155	1,175
	Weight		kg	99	126	208	209	266	322	377
	Fan	Air Volume	CMH	4,000	5,000	6,250	7,500	10,000	12,500	15,000
			CFM	2,354	2,943	3,679	4,415	5,886	7,358	8,829
		ESP	Pa	145	175	200	200	250	300	300
		Power Supply	V/Ph/Hz	220~240/1/50			380~415/3/50			
	Sound Pressure Level		dB(A)	64	65	65	65	66	66	67
Condensate Water Pipe Dimension		mm (in)	25.4 (1")							
Outdoor Unit	Compressor Type		Scroll Compressor							
	Condenser Type		Crossed Finned Cu Tube with Al Fin							
	Dimension	Width	mm	1,308	1,118	1,118	1,118	1,118x2	1,118x2	1,118x2
		Length	mm	508	1,012	1,012	1,012	1,012x2	1,012x2	1,012x2
		Height	mm	951	1,035	1,035	1,035	1,035	1,035	1,035
	Weight		kg	158	199	202	198	199x2	202x2	198x2
Power Supply		V/Ph/Hz	380~415/3/50							
Total Input Power		kW	7.60	10.43	12.85	16.15	22.59	26.24	32.29	
Total Input Current		A	17.70	26.19	23.84	32.36	42.87	48.40	63.99	
Refrigerant	Refrigerant Charge	kg	5.20	7.00	7.90	9.70	7.30x2	7.70x2	9.25x2	
	Type		R410A							
	Pre-charge Gas		Nitrogen Holding Charge							
	Pipe Connection Type		Brazed							
Connecting Pipe Dimension	Liquid Pipe	mm (in)	12.70 (1/2")	12.70 (1/2")	12.70 (1/2")	15.88 (5/8")	12.70x2 (1/2"x2)	12.70x2 (1/2"x2)	15.88x2 (5/8"x2)	
		Suction Pipe	mm (in)	22.20 (7/8")	25.40 (1")	28.58 (1 1/8")	34.92 (1 3/8")	25.40x2 (1"x2)	28.58x2 (1 1/8"x2)	34.92x2 (1 3/8"x2)

Note:

1. Products are tested in accordance to ARI340/360.
2. Cooling capacity is based on 26.7 °C DB / 19.4 °C WB for indoor air, 35.0 °C DB / 23.9 °C WB ambient temperature.
3. Air volume is based on high fan speed.
4. Equivalent length of pipe used in performance test is 10m.
5. External static pressure data shown is for standard unit.
6. Products are not pre-charged with refrigerant upon leaving factory.
7. The noise level is measured in test-room condition. The actual noise level at site will differ due to environmental noise or other reasons.
8. Special design Desuperheater heat recovery option: please contact factory.
9. The manufacturer reserves the rights to change the specifications without prior notice.

## General Data - Air-Cooled Split Ducted R410A (50Hz)

Model	Indoor Unit	FASN	350		400	450	500	600	750
	Outdoor Unit	FASD	100	125x2	100x4	150x3	125x4	150x4	150x5
Total Cooling Capacity		kW	102.6		117.2	131.9	146.5	175.8	219.8
		Btu/h	350,000		400,000	450,000	500,000	600,000	750,000
Indoor Unit	Type		Double Skin						
	Dimension	Width	mm	2,081	2,432	2,787	2,782	2,782	2,782
		Length	mm	1,547	1,547	1,637	1,637	1,737	1,859
		Height	mm	1,450	1,450	1,450	1,450	1,650	2,006
	Weight		kg	380	584	644	644	852	879
	Fan	Air Volume	CMH	17,500	20,000	22,500	25,000	30,000	37,500
			CFM	10,500	11,772	13,244	14,715	17,658	22,073
		ESP	Pa	300	300	350	400	400	450
		Power Supply	V/Ph/Hz	380~415/3/50					
	Sound Pressure Level		dB(A)	67	68	68	68	70	70
Condensate Water Pipe Dimension		mm (in)	25.4 (1")						
Outdoor Unit	Compressor Type		Scroll Compressor						
	Condenser Type		Crossed Finned Cu Tube with Al Fin						
	Dimension	Width	mm	1,118x3	1,118x4	1,118x3	1,118x4	1,118x4	1,118x5
		Length	mm	1,012x3	1,012x4	1,012x3	1,012x4	1,012x4	1,012x5
		Height	mm	1,035	1,035	1,035	1,035	1,035	1,035
	Weight		kg	199	202x2	199x4	198x3	202x4	198x4
Power Supply		V/Ph/Hz	380~415/3/50						
Total Input Power		kW	37.96	45.35	49.28	54.06	66.55	83.31	
Total Input Current		A	67.99	86.82	96.12	99.45	128.65	164.50	
Refrigerant	Refrigerant Charge	kg	7.00	7.70x2	7.30x4	9.25x3	7.70x4	9.25x4	9.25x5
	Type		R410A						
	Pre-charge Gas		Nitrogen Holding Charge						
	Pipe Connection Type		Brazed						
Connecting Pipe Dimension	Liquid Pipe	mm (in)	12.70x3		12.70x4	15.88x3	12.70x4	15.88x4	15.88x5
			(1/2"x3)		(1/2"x4)	(5/8"x3)	(1/2"x4)	(5/8"x4)	(5/8"x5)
	Suction Pipe	mm (in)	25.40	28.58x2	25.40x4	34.92x3	28.58x4	34.92x4	34.92x5
			(1")	(1 1/8"x2)	(1"x4)	(1 3/8"x3)	(1 1/8"x4)	(1 3/8"x4)	(1 3/8"x5)

Note:

1. Products are tested in accordance to ARI340/360.
2. Cooling capacity is based on 26.7 °C DB / 19.4 °C WB for indoor air, 35.0 °C DB / 23.9 °C WB ambient temperature.
3. Air volume is based on high fan speed.
4. Equivalent length of pipe used in performance test is 10m.
5. External static pressure data shown is for standard unit.
6. Products are not pre-charged with refrigerant upon leaving factory.
7. The noise level is measured in test-room condition. The actual noise level at site will differ due to environmental noise or other reasons.
8. Special design Desuperheater heat recovery option: please contact factory.
9. The manufacturer reserves the rights to change the specifications without prior notice.

## General Data - Air-Cooled Split Ducted R410A (60Hz)

Model	Indoor Unit	FASN	80	100	125	150	200	250	300	
	Outdoor Unit	FASD	80	100	125	150	100x2	125x2	150x2	
Total Cooling Capacity		kW	23.4	29.3	36.6	44.0	58.6	73.3	87.9	
		Btu/h	80,000	100,000	125,000	150,000	200,000	250,000	300,000	
Indoor Unit	Type		Single Skin				Double Skin			
	Dimension	Width	mm	1,431	1,731	1,872	1,872	2,248	2,241	2,152
		Length	mm	940	940	1,140	1,140	1,297	1,347	1,547
		Height	mm	441	441	700	700	780	1,155	1,175
	Weight		kg	99	126	208	209	266	322	377
	Fan	Air Volume	CMH	4,000	5,000	6,250	7,500	10,000	12,500	15,000
			CFM	2,354	2,943	3,679	4,415	5,886	7,358	8,829
		ESP	Pa	145	175	200	200	250	300	300
		Power Supply	V/Ph/Hz	220/1/60			380/3/60			
	Sound Pressure Level		dB(A)	66	67	67	67	68	68	69
Condensate Water Pipe Dimension		mm (in)	25.4 (1")							
Outdoor Unit	Compressor Type		Scroll Compressor							
	Condenser Type		Crossed Finned Cu Tube with Al Fin							
	Dimension	Width	mm	1,308	1,118	1,118	1,118	1,118x2	1,118x2	1,118x2
		Length	mm	508	1,012	1,012	1,012	1,012x2	1,012x2	1,012x2
		Height	mm	951	1,035	1,035	1,035	1,035	1,035	1,035
	Weight		kg	158	199	202	198	199x2	202x2	198x2
Power Supply		V/Ph/Hz	380/3/60							
Total Input Power		kW	9.94	12.41	13.88	17.40	24.01	28.66	34.83	
Total Input Current		A	22.76	30.90	26.50	31.86	46.00	57.70	65.70	
Refrigerant	Refrigerant Charge	kg	4.10	6.20	6.40	8.70	6.20x2	6.40x2	8.70x2	
	Type		R410A							
	Pre-charge Gas		Nitrogen Holding Charge							
	Pipe Connection Type		Brazed							
Connecting Pipe Dimension	Liquid Pipe	mm (in)	12.70 (1/2")	12.70 (1/2")	12.70 (1/2")	15.88 (5/8")	12.70x2 (1/2"x2)	12.70x2 (1/2"x2)	15.88x2 (5/8"x2)	
		mm (in)	22.20 (7/8")	25.40 (1")	28.58 (1 1/8")	34.92 (1 3/8")	25.40x2 (1"x2)	28.58x2 (1 1/8"x2)	34.92x2 (1 3/8"x2)	
	Suction Pipe	mm (in)	22.20 (7/8")	25.40 (1")	28.58 (1 1/8")	34.92 (1 3/8")	25.40x2 (1"x2)	28.58x2 (1 1/8"x2)	34.92x2 (1 3/8"x2)	
		mm (in)	22.20 (7/8")	25.40 (1")	28.58 (1 1/8")	34.92 (1 3/8")	25.40x2 (1"x2)	28.58x2 (1 1/8"x2)	34.92x2 (1 3/8"x2)	

Note:

1. Products are tested in accordance to ARI340/360.
2. Cooling capacity is based on 26.7 °C DB / 19.4 °C WB for indoor air, 35.0 °C DB / 23.9 °C WB ambient temperature.
3. Air volume is based on high fan speed.
4. Equivalent length of pipe used in performance test is 10m.
5. External static pressure data shown is for standard unit.
6. Products are not pre-charged with refrigerant upon leaving factory.
7. The noise level is measured in test-room condition. The actual noise level at site will differ due to environmental noise or other reasons.
8. Special design Desuperheater heat recovery option: please contact factory.
9. The manufacturer reserves the rights to change the specifications without prior notice.

## General Data - Air-Cooled Split Ducted R410A (60Hz)

Model	Indoor Unit	FASN	350		400	450	500	600	750	
	Outdoor Unit	FASD	100	125x2	100x4	150x3	125x4	150x4	150x5	
Total Cooling Capacity		kW	102.6		117.2	131.9	146.5	175.8	219.8	
		Btu/h	350,000		400,000	450,000	500,000	600,000	750,000	
Indoor Unit	Type		Double Skin							
	Dimension	Width	mm	2,081		2,432	2,787	2,782	2,782	2,782
		Length	mm	1,547		1,547	1,637	1,637	1,737	1,859
		Height	mm	1,450		1,450	1,450	1,450	1,650	2,006
	Weight		kg	380		584	644	644	852	879
	Fan	Air Volume	CMH	17,500		20,000	22,500	25,000	30,000	37,500
			CFM	10,500		11,772	13,244	14,715	17,658	22,073
		ESP	Pa	300		300	350	400	400	450
		Power Supply	V/Ph/Hz	380/3/60						
	Sound Pressure Level		dB(A)	69		70	70	70	72	72
Condensate Water Pipe Dimension		mm (in)	25.4 (1")							
Outdoor Unit	Compressor Type		Scroll Compressor							
	Condenser Type		Crossed Finned Cu Tube with Al Fin							
	Dimension	Width	mm	1,118x3		1,118x4	1,118x3	1,118x4	1,118x4	1,118x5
		Length	mm	1,012x3		1,012x4	1,012x3	1,012x4	1,012x4	1,012x5
		Height	mm	1,035		1,035	1,035	1,035	1,035	1,035
	Weight		kg	199	202x2	199x4	198x3	202x4	198x4	198x5
Power Supply		V/Ph/Hz	380/3/60							
Total Input Power		kW	40.32		47.59	53.09	58.50	71.58	89.10	
Total Input Current		A	77.40		94.50	96.40	114.40	131.10	165.50	
Refrigerant	Refrigerant Charge	kg	6.20	6.40x2	6.20x4	8.70x3	6.40x4	8.70x4	8.70x5	
	Type		R410A							
	Pre-charge Gas		Nitrogen Holding Charge							
	Pipe Connection Type		Brazed							
Connecting Pipe Dimension	Liquid Pipe	mm (in)	12.70x3		12.70x4	15.88x3	12.70x4	15.88x4	15.88x5	
			(1/2"x3)		(1/2"x4)	(5/8"x3)	(1/2"x4)	(5/8"x4)	(5/8"x5)	
	Suction Pipe	mm (in)	25.40	28.58x2	25.40x4	34.92x3	28.58x4	34.92x4	34.92x5	
			(1")	(1 1/8"x2)	(1"x4)	(1 3/8"x3)	(1 1/8"x4)	(1 3/8"x4)	(1 3/8"x5)	

Note:

1. Products are tested in accordance to ARI340/360.
2. Cooling capacity is based on 26.7 °C DB / 19.4 °C WB for indoor air, 35.0 °C DB / 23.9 °C WB ambient temperature.
3. Air volume is based on high fan speed.
4. Equivalent length of pipe used in performance test is 10m.
5. External static pressure data shown is for standard unit.
6. Products are not pre-charged with refrigerant upon leaving factory.
7. The noise level is measured in test-room condition. The actual noise level at site will differ due to environmental noise or other reasons.
8. Special design Desuperheater heat recovery option: please contact factory.
9. The manufacturer reserves the rights to change the specifications without prior notice.



## Electrical Data - Air Cooled Split Ducted R410A (50Hz)

VOLT	ITEM		FASN/ FASD080	FASN/ FASD100	FASN/ FASD125	FASN/ FASD150	FASN/ FASD200
415V	TOTAL POWER INPUT	kW	7.60	10.43	12.85	16.15	22.59
	TOTAL RUN CURRENT	A	17.70	26.19	23.84	32.36	42.87
	POWER FACTOR	%	60	55	75	69	73
	COMPRESSOR POWER INPUT	kW	6.44	8.80	10.45	12.80	17.60
	RUN CURRENT	A	11.90	16.80	18.80	25.30	33.60
	Outdoor FAN POWER INPUT	kW	0.72	0.99	0.99	1.45	1.98
	RUN CURRENT	A	1.60	1.80	1.80	2.60	3.60
	Indoor FAN POWER INPUT	kW	0.44	0.64	1.41	1.90	3.01
	RUN CURRENT	A	4.20	7.59	3.24	4.46	5.67
	Indoor FAN POWER OUTPUT	kW	0.375	0.55	1.50	2.20	3.00
	MOTOR POLE		4	4	4	4	4

VOLT	ITEM		FASN/ FASD250	FASN/ FASD300	FASN/ FASD350	FASN/ FASD400	FASN/ FASD450
415V	TOTAL POWER INPUT	kW	26.24	32.29	37.96	45.35	49.28
	TOTAL RUN CURRENT	A	48.40	63.99	67.99	86.82	96.12
	POWER FACTOR	%	75	70	78	73	71
	COMPRESSOR POWER INPUT	kW	20.90	25.60	29.70	35.20	38.40
	RUN CURRENT	A	37.60	50.60	54.40	67.20	75.90
	Outdoor FAN POWER INPUT	kW	1.98	2.90	2.97	3.96	4.35
	RUN CURRENT	A	3.60	5.20	5.40	7.20	7.80
	Indoor FAN POWER INPUT	kW	3.36	3.79	5.29	6.19	6.53
	RUN CURRENT	A	7.20	8.19	8.19	12.42	12.42
	Indoor FAN POWER OUTPUT	kW	4.00	5.50	5.50	7.50	7.50
	MOTOR POLE		4	4	4	4	4

VOLT	ITEM		FASN/ FASD500	FASN/ FASD600	FASN/ FASD750
415V	TOTAL POWER INPUT	kW	54.06	66.55	83.31
	TOTAL RUN CURRENT	A	99.45	128.65	164.50
	POWER FACTOR	%	76	72	70
	COMPRESSOR POWER INPUT	kW	41.80	51.20	64.00
	RUN CURRENT	A	75.20	101.20	126.50
	Outdoor FAN POWER INPUT	kW	3.96	5.80	7.25
	RUN CURRENT	A	7.20	10.40	13.00
	Indoor FAN POWER INPUT	kW	8.30	9.55	12.06
	RUN CURRENT	A	17.05	17.05	25.00
	Indoor FAN POWER OUTPUT	kW	11.00	11.00	15.00
	MOTOR POLE		4	4	4

## Electrical Data - Air Cooled Split Ducted R410A (60Hz)

VOLT	ITEM		FASN/ FASD080	FASN/ FASD100	FASN/ FASD125	FASN/ FASD150	FASN/ FASD200
380V	TOTAL POWER INPUT	kW	9.94	12.41	13.88	17.40	24.01
	TOTAL RUN CURRENT	A	22.76	30.90	26.50	31.86	46.00
	POWER FACTOR	%	61	56	73	76	73
	COMPRESSOR POWER INPUT	kW	7.55	9.45	10.95	13.90	18.90
	RUN CURRENT	A	12.90	17.70	20.20	24.20	35.40
	Outdoor FAN POWER INPUT	kW	0.85	1.09	1.64	1.64	2.18
	RUN CURRENT	A	1.70	2.00	2.70	2.70	4.00
	Indoor FAN POWER INPUT	kW	1.54	1.87	1.29	1.86	2.93
	RUN CURRENT	A	8.16	11.20	3.60	4.96	6.60
	Indoor FAN POWER OUTPUT	kW	0.375	0.55	1.50	2.20	3.00
MOTOR POLE			4	4	4	4	4

VOLT	ITEM		FASN/ FASD250	FASN/ FASD300	FASN/ FASD350	FASN/ FASD400	FASN/ FASD450
380V	TOTAL POWER INPUT	kW	28.66	34.83	40.32	47.59	53.09
	TOTAL RUN CURRENT	A	57.70	65.70	77.40	94.50	96.40
	POWER FACTOR	%	69	74	72	70	77
	COMPRESSOR POWER INPUT	kW	21.90	27.80	31.35	37.80	41.70
	RUN CURRENT	A	40.40	48.40	58.10	70.80	72.60
	Outdoor FAN POWER INPUT	kW	3.28	3.28	4.37	4.36	4.92
	RUN CURRENT	A	5.40	5.40	7.40	8.00	8.10
	Indoor FAN POWER INPUT	kW	3.48	3.75	4.60	5.43	6.47
	RUN CURRENT	A	11.90	11.90	11.90	15.70	15.70
	Indoor FAN POWER OUTPUT	kW	4.00	5.50	5.50	7.50	7.50
MOTOR POLE			4	4	4	4	4

VOLT	ITEM		FASN/ FASD500	FASN/ FASD600	FASN/ FASD750
380V	TOTAL POWER INPUT	kW	58.50	71.58	89.10
	TOTAL RUN CURRENT	A	114.40	131.10	165.50
	POWER FACTOR	%	71	76	75
	COMPRESSOR POWER INPUT	kW	43.80	55.60	69.50
	RUN CURRENT	A	80.80	96.80	121.00
	Outdoor FAN POWER INPUT	kW	6.56	6.56	8.20
	RUN CURRENT	A	10.80	10.80	13.50
	Indoor FAN POWER INPUT	kW	8.14	9.42	11.40
	RUN CURRENT	A	22.80	23.50	31.00
	Indoor FAN POWER OUTPUT	kW	11.00	11.00	15.00
MOTOR POLE			4	4	4

## Operating Range

### Cooling

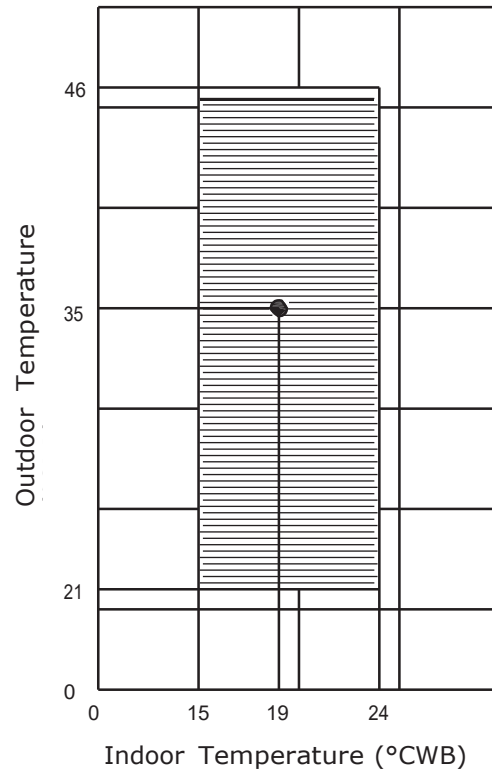

# System Schematic Diagram

Model: FASN080 / 100 / 125 / 150

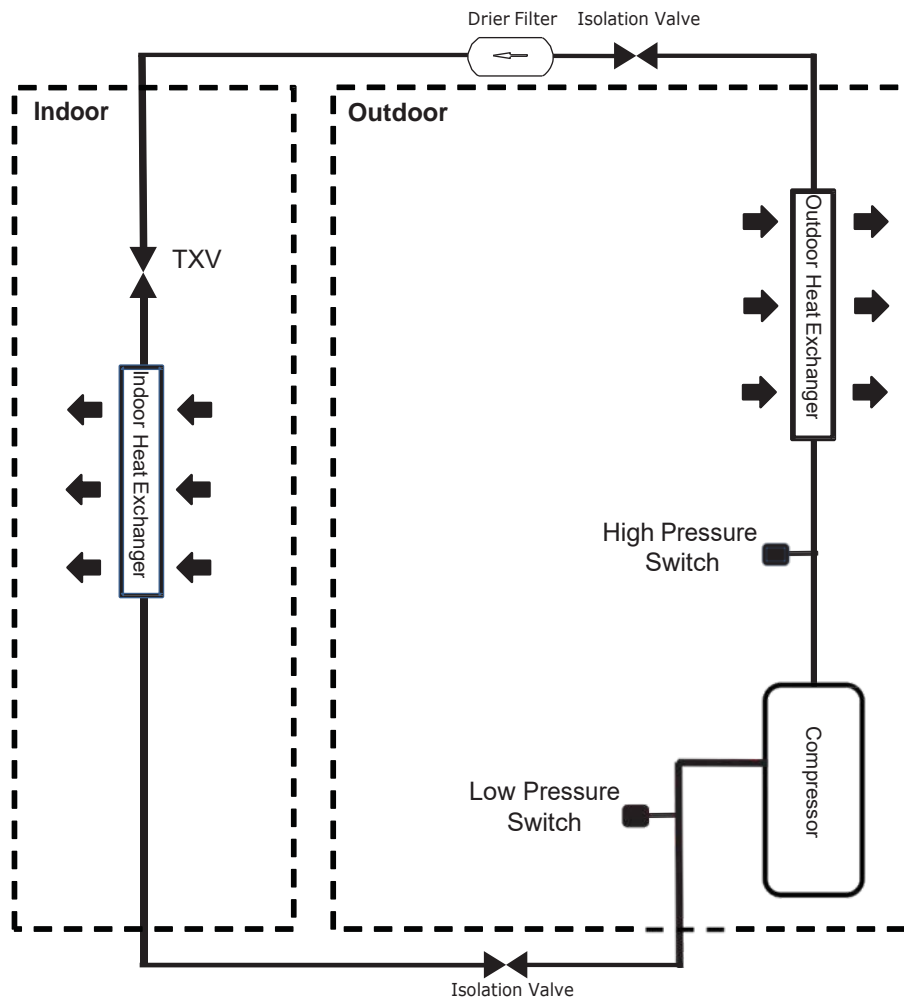

Note: Contractor is suggested to install Isolation Valve(s) and Drier Filter(s)

# System Schematic Diagram

Model: FASN200/250/300

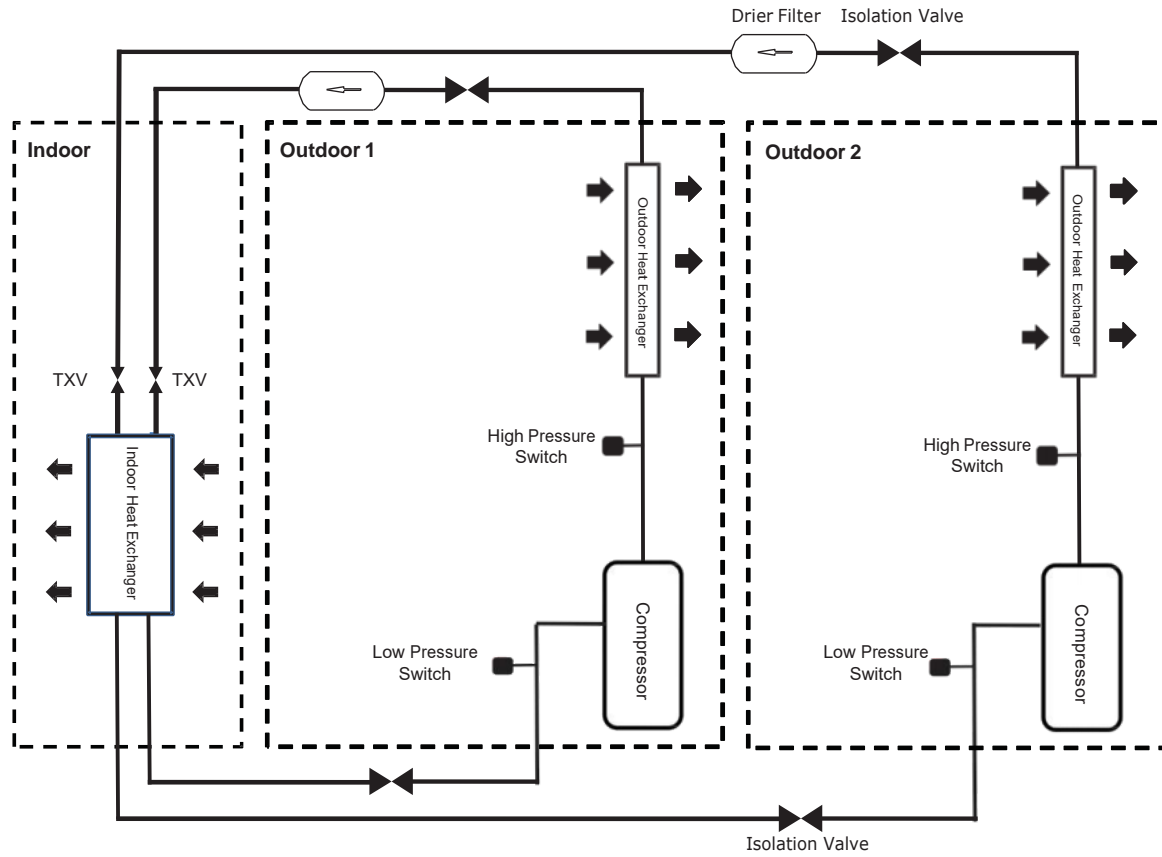

Note: Contractor is suggested to install Isolation Valve(s) and Drier Filter(s)

# System Schematic Diagram

Model: FASN350/450

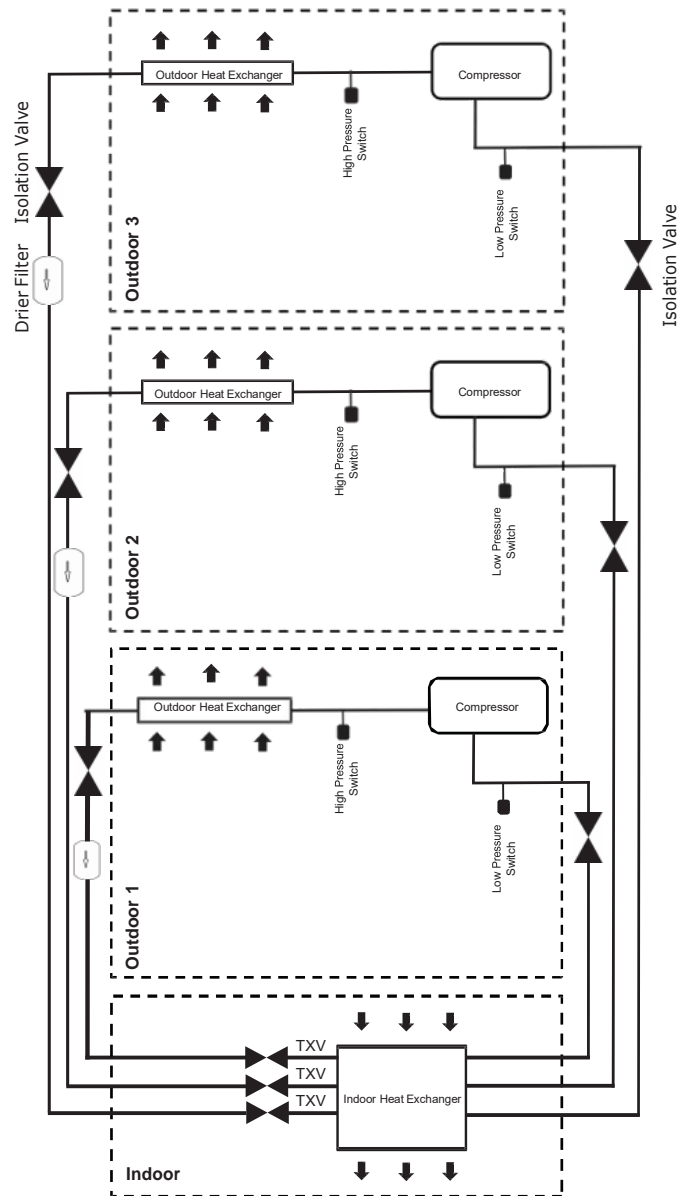

Note: Contractor is suggested to install Isolation Valve(s) and Drier Filter(s)

# System Schematic Diagram

Model: FASN400/500/600

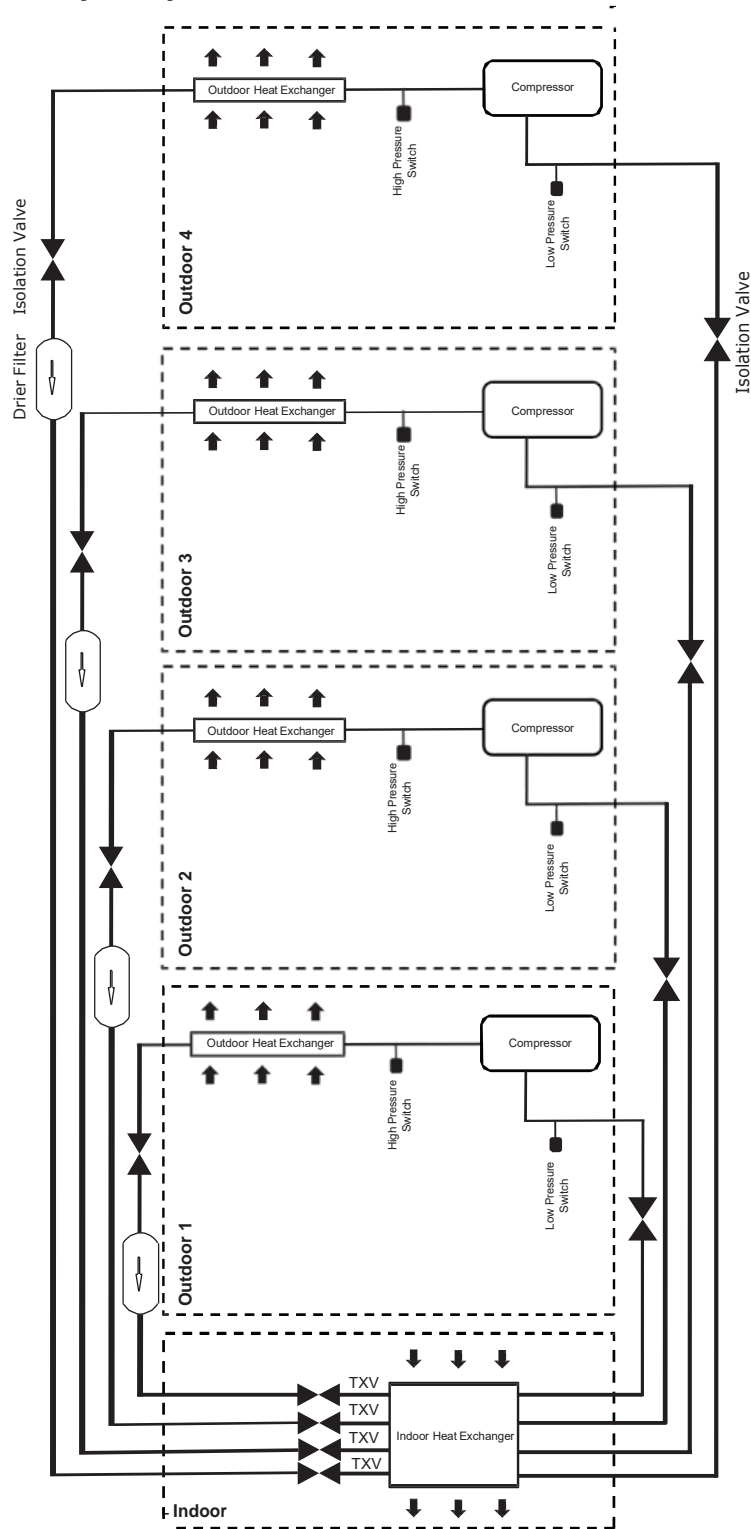

Note: Contractor is suggested to install Isolation Valve(s) and Drier Filter(s)

# System Schematic Diagram

Model: FASN750

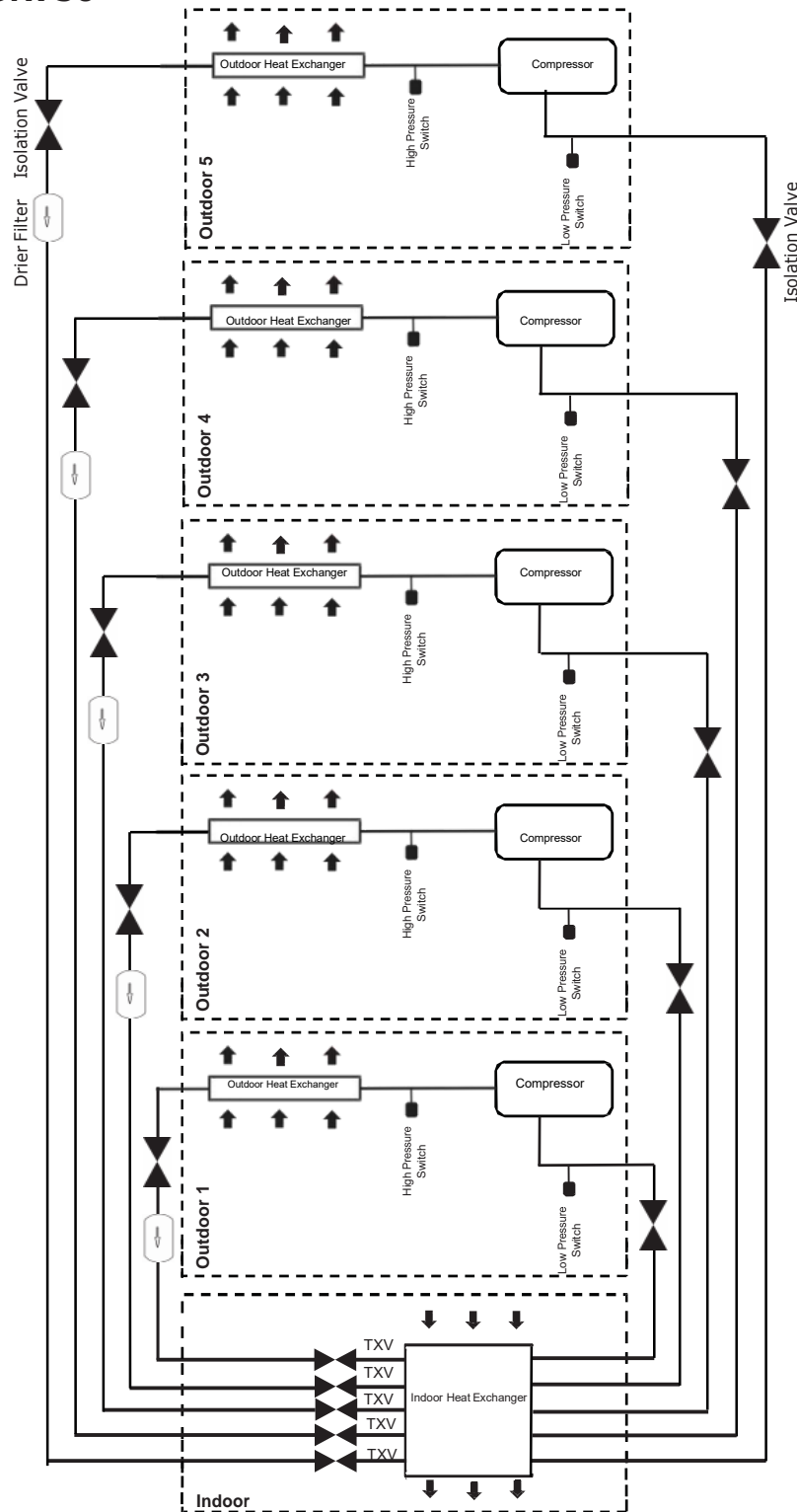

Note: Contractor is suggested to install Isolation Valve(s) and Drier Filter(s)



## Controller Features and Algorithm (Optional)

### Single stage operation instruction for FASN 80~150

#### Use of buttons on LED wall pad controller

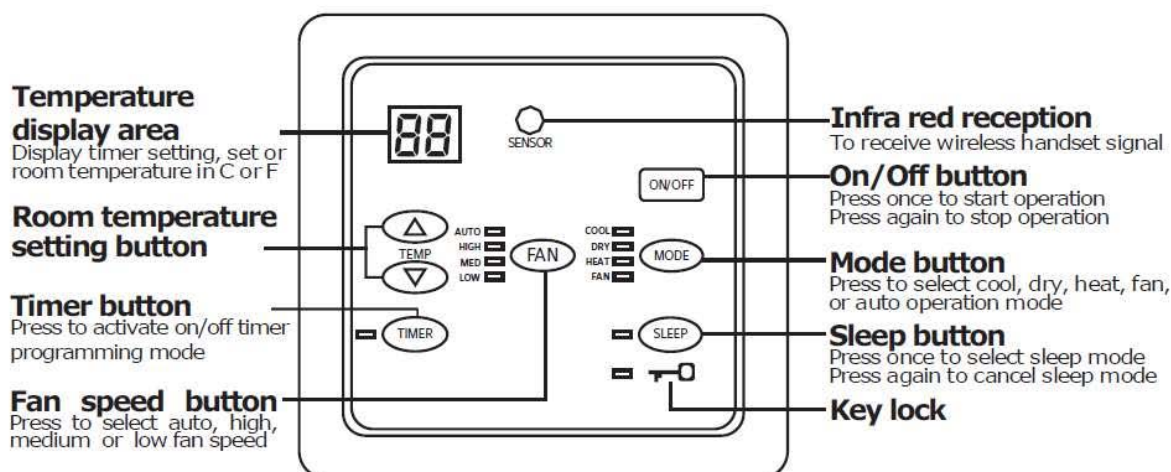

#### Operation Instruction

1. Press **ON/OFF** to start or stop the air conditioner.
2. Temperature Setting
  - Press **▲** or **▼** to decrease or increase the set temperature. When any of these buttons are pressed, temperature display area will flash with the old temperature setting for 4 seconds. Should there be no further key press it will then return to room temperature display in the range of 16C-30C.
  - Press **▼** or **FAN** together for 5 seconds will change the temperature setting from C to F. Valid temperature set range is 16C-30C or 60F-85F. Temperature setting is bypass in Fan mode.

### 3. Mode setting

- Press **MODE** button to change the operation mode as follow:  
Cool → dry → heat → fan → auto cool/heat
- Heat LED flashes during outdoor defrost cycle. **MODE** button is invalid during this cycle.

### 4. Fan speed setting

- Press **FAN** button to change the fan speed:  
Auto → High → Medium → Low  
Auto fan setting is bypassed in Fan mode. Fan speed setting is bypassed in dry mode.



### 5. Sleep setting

- Press **SLEEP** button to active or deactivate sleep setting. Sleep is bypassed in Fan and Dry mode.



### 6. On/Off timer setting



- When the system is on, setting the timer will turn off the unit after the programmed hours are counted down. When the system is off, setting the timer will turn on the unit after the programmed hours are counted down.
- Press **TIMER** button once to activate on/off timer programming mode. Timer LED and temperature display area flash for 3 seconds showing the number of countdown hours left. Thereafter, Timer LED flashes and temperature display area shows the timer setting.
- Press **TIMER** again to set the timer from 1 to 24 hours in 1hour increments in a round-robin pattern. Holding down this key will change the timer setting automatically every half second.  
Cool → dry → heat → fan → auto cool/heat
- Heat LED flashes during outdoor defrost cycle. **MODE** button is invalid during this cycle. Pressing **TIMER FAN** until the display shows "-" will cancel the timer setting. Should there be no further button press, system will exit from on timer programming mode automatically. Timer LED will light up if on/off timer is set.
- Pressing **ON/OFF** to start or stop the air conditioner will also cancel the timer setting.





## 7. Key Lock

- In order to prevent unauthorized access to the system settings, a key lock function is provided to prevent mischief. When the system is on, hold down  and  buttons for 3 seconds to activate the key lock function, key lock symbol  will light up. Repeat the same sequence to cancel key lock function. The following operation are allowed in this mode.



7.1 Press  to start or stop the air conditioner.

7.2 Hold down  and  button for 1 second to activate coil temperature display function. Repeat the same sequence to cancel coil temperature display function.

Temperature display will show the coil temperature selected in the range of - 9°C to 78°C. Press  button to select indoor coil temperature display and high fan LED flashes. Press  button to select outdoor coil temperature display and medium fan LED flashes. For dual-stage system, press  to select the data of the system to be displayed. Timer LED flashes showing the data for #2 system.

7.3 Hold down  and  buttons for 1 second to activate defrost termination temperature setting and auto fan LED flashes. Repeat the same sequence to cancel this function. Press  and  button to change the setting from 10°C-15°C. for dual-stage system, press  to select the data of the system to be displayed. Timer LED flashes showing the data for #2 system.

## 8. Time shortening

- This function is to activate the time shortening program in the main board. It must be used with care and is recommended for PCB testing only. This function can only be activated within 1 minute after system is powered on. Hold down  and  buttons to activate this function.

#### 9. Error code display

- Should there be any fault with the main board, the relevant error code will be shown on the temperature display area. If multiple faults happen at the same time, the error code will be shown one after another. System will alternate the display of error code and room temperature.
- Depending on the model of main board, the error codes available are:

<b>Fault</b>	<b>Error Code</b>	<b>Remark</b>
Room sensor failure	E1	
#1 indoor coil sensor failure	E2	
#1 outdoor coil sensor failure	E3	
#1 insufficient refrigerant	E4	
#1 compressor overload	E5	
#1 low pressure failure	E6	
#1 high pressure failure	E7	
Water source temperature	E8	Water source unit only
#2 indoor coil sensor failure	E9	
#2 outdoor coil sensor failure	EA	
#2 insufficient refrigerant	EB	
#2 compressor overload	EC	
#2 low pressure failure	ED	
#2 high pressure failure	EE	
Flow switch failure	EF	Water source unit only
Condensate water drainage failure	E0	Water source unit only

#### 10. Infrared signal reception

- The system is able to receive the infrared wireless commands from non-LCD handsets.

#### 11. Master-Slave

- If the wall pad is connected to a gateway card, a master controller can control it. If the master controller is working in global control mode, key lock LED flashes. None of the button or infra-red reception will be acknowledged until master controller gives up global control mode.

## Controller Features and Algorithm (Optional)

### Multi-stage operation instruction for FASN 200~750

#### Wall pad



Button/key Description (Details refer to operation guide):





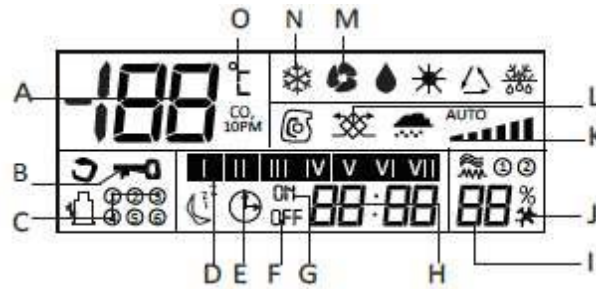

- DAY: Set day of week
- TIME+/-: Adjust clock
- CLOCK: Set clock
- CANCEL: Cancel timer
- TIMER: Set on/off timer
- MODE: Set operation mode
- SET: Set parameter
- DISPLAY: Browse temperature
- SELECT+/-: Menu selection
- RESET: Reset fault
- TiO2: TiO2 on/off

## LCD Display Description:



- A. Return air or set temperature display section. This section has no indication if system in standby mode and backlight is off.
- B. Wall pad key lock symbol. Symbol appears if wall pad keypad is locked and vice versa.
- C. Compressor status indication. Symbol will light up if its corresponding compressor is running.
- D. Day display from Monday to Sunday.
- E. On/Off timer setting symbol. During on/off timer setting mode, this symbol and For G symbol flashes. In none timer setting mode, this symbol will light up should there be any on/off timer being set.
- F. Off symbol. During off timer setting mode, this symbol and D symbol flashes. In none off timer setting mode, this symbol will light up should be unexecuted off timer for the current day.
- G. On symbol. During on timer setting mode, this symbol and D symbol flashes. In none on timer setting mode, this symbol will light up should be unexecuted on timer for the current day.
- H. Clock display. In temperature browsing mode it shows the temperature being searched. In parameter setting mode, it shows the set parameter.
- I. It shows the error code if there is system failure. It shows the menu number in temperature browsing or parameter setting mode.
- J. Error symbol flashes if there is system failure and vice versa.
- K. Indoor fan status indication. This symbol lights up if indoor fan is running and vice versa.
- L. TiO2 status indication. This symbol lights up if TiO2 is on and vice versa.
- M. Symbol lights up in Fan mode and vice versa.
- N. Symbol lights up in Cool mode and vice versa.
- O. Symbol flashes in temperature setting mode.

## Wall pad guide:

1. On/Off control
  - Press  button to control system on/off. If the unit is off, press  will turn on the system with two beeping sounds. If the unit is on, press  to turn off the unit with one beeping sound.
2. Temperature setting
  - Press  and  button to adjust the temperature setting from 16°C to 30°C.
3. Mode Setting
  - Press **<MODE>** button to select Cool or Fan mode.
4. Clock Setting
  - System has a build-in real-time clock for time indication and on/off timer control. Press **<CLOCK>** button to enter into clock setting mode and second indication stop flashing. Press **<TIME+/->** button to adjust the system clock. Press **<CLOCK>** button once mode to exit the clock setting mode. Second indication resume flashing.
5. Day Setting
  - This wall pad supports the day indication. Day indication can be used for normal day display and on/off timer setting. Day display section shows the current day. Used the **<DAY>** button to adjust the day setting accordingly.
6. On/Off Timer Setting
  - The System supports 7 groups of on/off timer settings, i.e. 7-day weekly timer. Press **<TIMER>** button once, timer symbol flashes. Press **<TIMER>** button again, timer and ON symbol flash, system is now in on timer setting mode. The day display section shows the day of corresponding on timer setting. If clock display section shows --: --, it means the current timer is null. Pressing **<TIMER>** button will activate this timer. If time is being displayed, it means the current timer is activated. Pressing **<TIME+/->** button to adjust the timer setting. Press **<CANCEL>** button will cancel this setting and the display will be shown as --: --. Press **<TIMER>** button again, ON symbol is off while timer and OFF symbols flash, system is now in on timer setting mode. The day display section shows the day of the corresponding off timer setting.

If clock display section shows --: --, it means the current timer is null. Pressing **<TIME+/->** button will activate this timer. If time is being displayed, it means the current timer is activated. Press **<TIME+/->** button to adjust the timer setting. Pressing **<CANCEL>** button will cancel this setting and the display will be shown as --: --. Press **<TIMER>** button again, OFF symbol off and timer symbol flashes. Pressing **<CANCEL>** button will exit on/off timer setting. Press **<TIMER>** button again to repeat step a) to b). Press **<DAY>** button to adjust different day of on/off timer setting. In normal operation, timer symbol will light up should there be any on/off timer being set. Should there be unexecuted on or off timer for the current day, its corresponding on or off symbol will light up. In on/off timer setting mode, pressing **<CANCEL>** button for 5 sec will cancel all on/off timer settings.

#### 7. TiO2 Control

- Press **<TiO2>** button to start or stop TiO2 control. If TiO2 is off, press **<TiO2>** button to activate TiO2. If TiO2 is activated, press **<TiO2>** button to off TiO2.

### Temperature Browsing

In normal operation, press **<DISPLAY>** button to enter into temperature browsing menu. Press **<SELECT >** button to select the menu as follows:

For unit FASN/SD080~600

Menu (shown in error code display section)	Value (shown clock display section)	Unit	Remarks
C0	Mainboard DIP switch setting	Unit	Water source unit only
C1	Indoor coil 1 temperature	°C	
C2	Indoor coil 2 temperature	°C	
C3	Indoor coil 3 temperature	°C	If main board is configured as dual circuits, C3 and C4 cannot be selected.
C4	Indoor coil 4 temperature	°C	If main board is configured as dual and 3 circuits, c4 cannot be selected.

Press **<DISPLAY>** button again to exit.





For unit FASN/SD750 only

Menu (shown in error code display section)	Value (shown clock display section)	Unit	Remarks
C0	Mainboard DIP switch setting	Unit	Water source unit only
C1	Indoor coil 1/2 temperature	°C	
C2	Indoor coil 3 temperature	°C	
C3	Indoor coil 4 temperature	°C	If main board is configured as dual circuits, C3 and C4 cannot be selected.
C4	Indoor coil 5 temperature	°C	If main board is configured as dual and 3 circuits, c4 cannot be selected.

Press **<DISPLAY>** button again to exit.



#### 8. Key Lock

- System is equipped with key lock function to prevent mischief. Press  and  button for 5 seconds to activate key lock mode. Key lock symbol will light up, likewise to exit key lock mode. Only  button will be valid in key lock mode.

#### 9. Key Validity

- There are some buttons that will be acknowledged in certain functions only. The valid key press will be responded to with the beeping sound.

## 10. Parameter setting

- In normal mode, press **<SET>** button for 5 seconds to enter into parameter setting menu. Press **<SELECT >** button to select the menu items. Press **<SELECT ▲ / ▼ >** button to select the menu items. Press  and  button to edit the parameters as follows:

Menu (shown in error code display section)	Parameter (shown clock display section)	Characteristic	Remarks
d0	Recover to the state before power failure	Display as En: Recover	
		Display as Dn: Not Recover	
d1	Service password 1	0-99, default 0	
d2	Service password 1	0-99, default 0	
d3	Indoor coil anti-freeze	-10-2, default 0	
d4	Compressor consecutive cut in interval	3~8 min, default 5 min	
d5	Thermostatically control cycle	30~240 sec, default 90 sec	30sec/step
d6	Recover to default setting	Display as En: Recover	
		Display as Dn: Not Recover	

### Note:

- Upon entering parameter setting menu, "READ" status will be shown, indicating retrieving the data from the main board.
- At menu d1, a password of "16" is required to proceed to menu d2. If password is incorrect, system will exit parameter edit mode.
- At menu d2, a password of "32" is required to proceed to menu d3. If password is incorrect, system will exit parameter edit mode.
- Upon completion of parameter editing, press **<SET>** button to exit in order for the new setting to take effect.

## 11. Error Display

- Should an error occur, backlight will turn red color. Error display section shows the corresponding error codes as follow:

For unit FASN/SD200~600

Error Code	Description	Remarks
1	Indoor fan failure (power off to reset)	Display error, stop the system for protection. Power off and on to restart
2	Indoor return air sensor failure (auto reset)	Display error, resume upon recovery, default at 26°C
3	Indoor coil 1 sensor failure (auto reset)	Display error, system continue to operate, bypass anti-freeze
4	Indoor coil 2 sensor failure (auto reset)	Display error, system continue to operate, bypass anti-freeze
5	Indoor coil 3 sensor failure (auto reset)	Display error, system continue to operate, bypass anti-freeze
6	Indoor coil 4 sensor failure (auto reset)	Display error, system continue to operate, bypass anti-freeze
7	Outdoor unit 1 power protection, outdoor fan protection, external interlock, compressor 1 high/low pressure failure (manual reset)	Display error. Stop the outdoor unit, manual reset required, should the failure occur 5 times consecutively, pressing "RESET" will not be able to reset the unit. Power off and on to restart the unit.
8	Indoor coil 1 anti-freezing (auto reset)	Display error, stop the unit.
9	Circuit 1 no cooling (power off to reset)	Display error, stop the unit.
10	Outdoor unit 2 power protection, outdoor fan protection, external interlock, compressor 2 high/low pressure failure (manual reset)	Display error. Stop the outdoor unit, manual reset required, should the failure occur 5 times consecutively, pressing "RESET" will not be able to reset the unit. Power off and on to restart the unit.

Error Code	Description	Remarks
11	Indoor coil 2 anti-freezing (auto reset)	Display error, stop the unit.
12	Circuit 2 no cooling (power off to reset)	Display error, stop the unit.
13	Outdoor unit 3 power protection, outdoor fan protection, external interlock, compressor 3 high/low pressure failure (manual reset)	Display error. Stop the outdoor unit, manual reset required, should the failure occur 5 times consecutively, pressing "RESET" will not be able to reset the unit. Power off and on to restart the unit.
14	Indoor coil 3 anti-freezing (auto reset)	Display error, stop the unit.
15	Circuit 3 no cooling (power off to reset)	Display error, stop the unit.
16	Outdoor unit 4 power protection, outdoor fan protection, external interlock, compressor 4 high/low pressure failure (manual reset)	Display error. Stop the outdoor unit, manual reset required, should the failure occur 5 times consecutively, pressing "RESET" will not be able to reset the unit. Power off and on to restart the unit.
17	Indoor coil 4 anti-freezing (auto reset)	Display error, stop the unit.
18	Circuit 4 no cooling (power off to reset)	Display error, stop the unit.

Note: Failure of any circuit will not affect the operation of other circuits.

During system failure, press **<RESET>** button for 3 sec to reset the fault.

For unit FASN/SD750

Error Code	Description	Remarks
1	Indoor fan failure (power off to reset)	Display error, stop the system for protection. Power off and on to restart
2	Indoor return air sensor failure (auto reset)	Display error, resume upon recovery, default at 26°C
3	Indoor coil 1/2 sensor failure (auto reset)	Display error, system continue to operate, bypass anti-freeze
4	Indoor coil 3 sensor failure (auto reset)	Display error, system continue to operate, bypass anti-freeze
5	Indoor coil 4 sensor failure (auto reset)	Display error, system continue to operate, bypass anti-freeze
6	Indoor coil 5 sensor failure (auto reset)	Display error, system continue to operate, bypass anti-freeze
7	Outdoor unit 1/2 power protection, outdoor fan protection, external interlock, compressor 1 high/low pressure failure (manual reset)	Display error. Stop the outdoor unit, manual reset required, should the failure occur 5 times consecutively, pressing "RESET" will not be able to reset the unit. Power off and on to restart the unit.
8	Indoor coil 1/2 anti-freezing (auto reset)	Display error, stop the unit.
9	Circuit 1/2 no cooling (power off to reset)	Display error, stop the unit.
10	Outdoor unit 3 power protection, outdoor fan protection, external interlock, compressor 3 high/low pressure failure (manual reset)	Display error. Stop the outdoor unit, manual reset required, should the failure occur 5 times consecutively, pressing "RESET" will not be able to reset the unit. Power off and on to restart the unit.
11	Indoor coil 3 anti-freezing (auto reset)	Display error, stop the unit.

Error Code	Description	Remarks
12	Circuit 3 no cooling (power off to reset)	Display error, stop the unit.
13	Outdoor unit 4 power protection, outdoor fan protection, external interlock, compressor 4 high/low pressure failure (manual reset)	Display error. Stop the outdoor unit, manual reset required, should the failure occur 5 times consecutively, pressing "RESET" will not be able to reset the unit. Power off and on to restart the unit.
14	Indoor coil 4 anti-freezing (auto reset)	Display error, stop the unit.
15	Circuit 4 no cooling (power off to reset)	Display error, stop the unit.
16	Outdoor unit 5 power protection, outdoor fan protection, external interlock, compressor 5 high/low pressure failure (manual reset)	Display error. Stop the outdoor unit, manual reset required, should the failure occur 5 times consecutively, pressing "RESET" will not be able to reset the unit. Power off and on to restart the unit.
17	Indoor coil 5 anti-freezing (auto reset)	Display error, stop the unit.
18	Circuit 5 no cooling (power off to reset)	Display error, stop the unit.

Note: Failure of any circuit will not affect the operation of other circuits.

During system failure, press **<RESET>** button for 3 sec to reset the fault.

## Fan Performance Curve

### FASN080

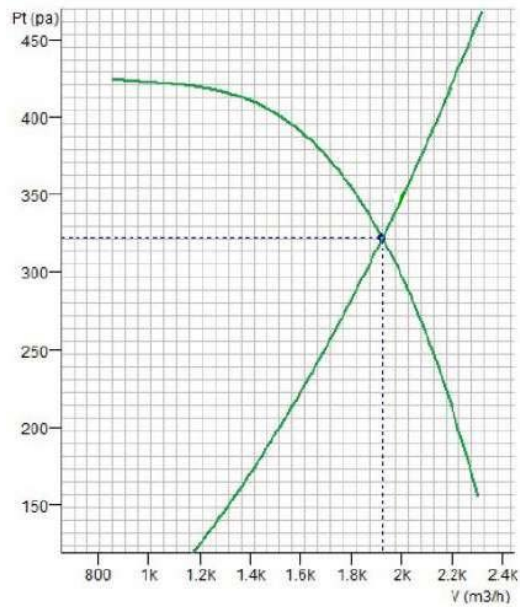

### FASN100

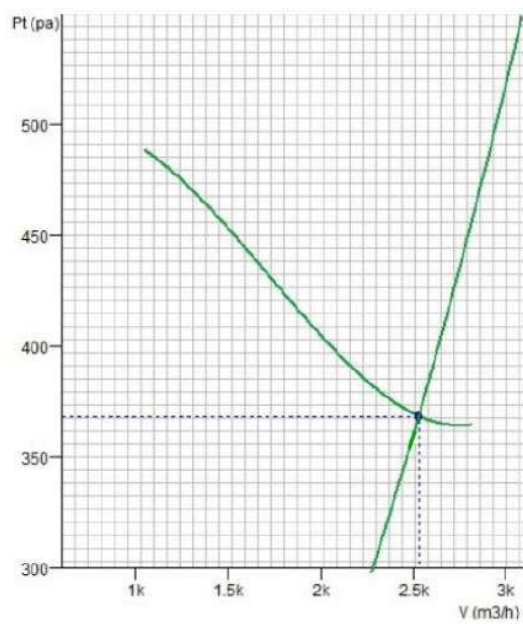

### FASN125

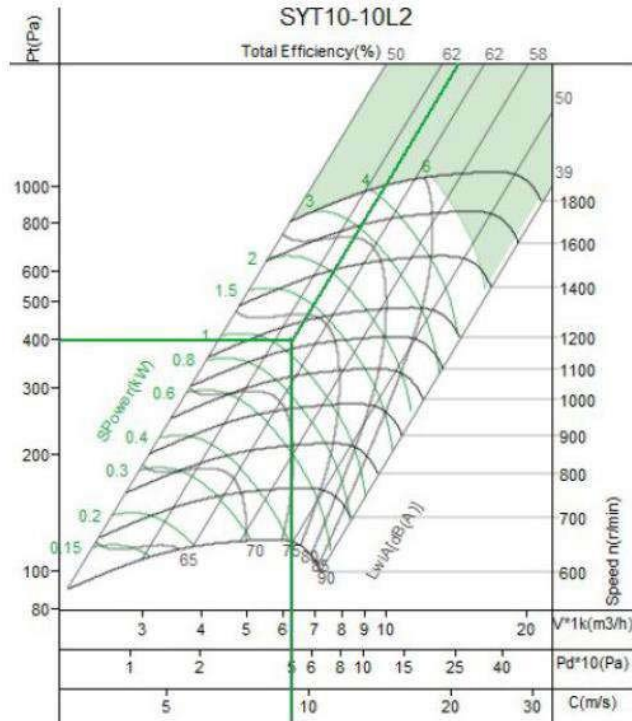

### FASN150

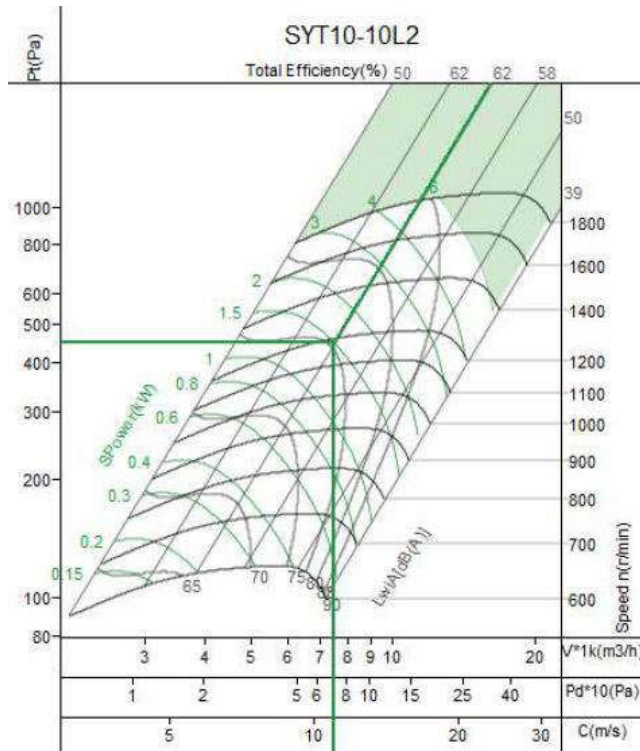



## FASN200

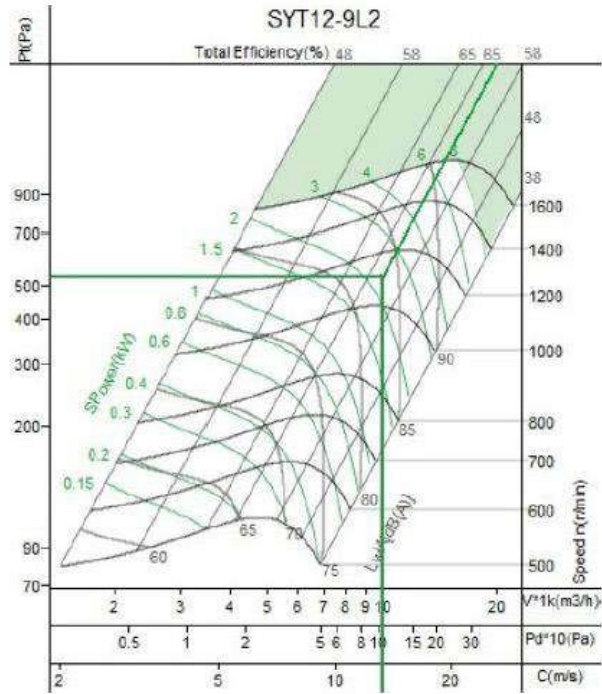

## FASN250

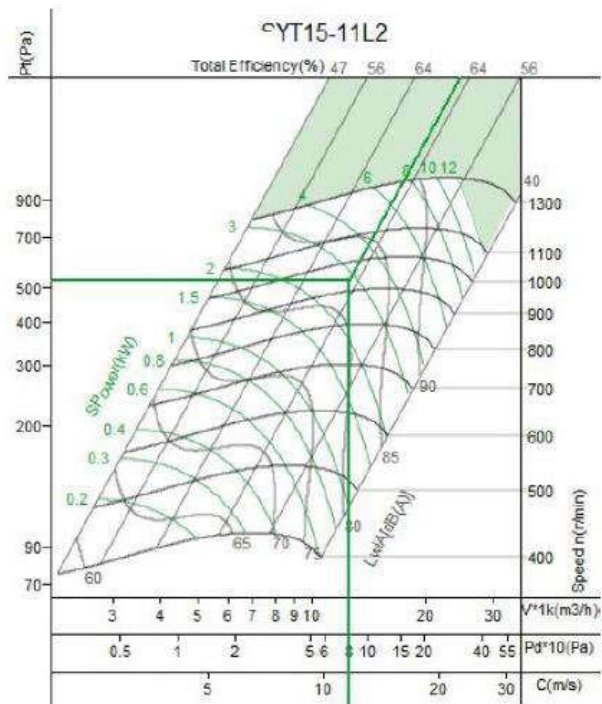

### FASN300

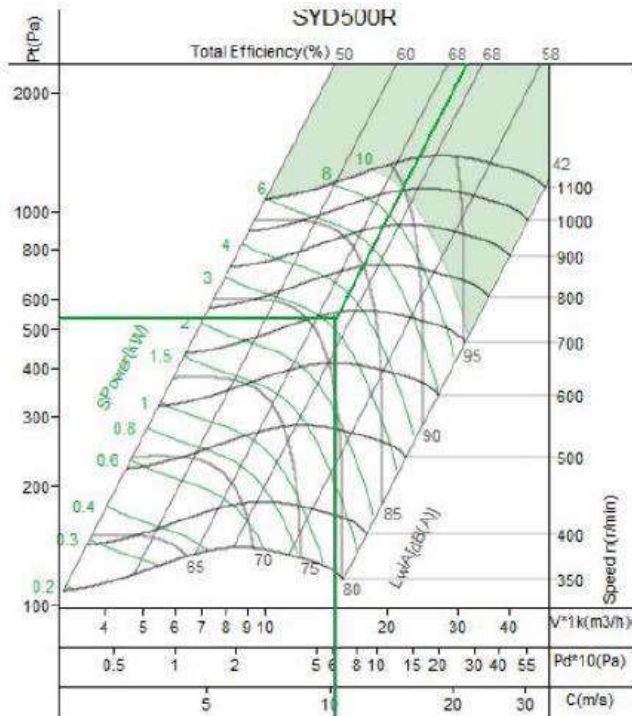

### FASN350

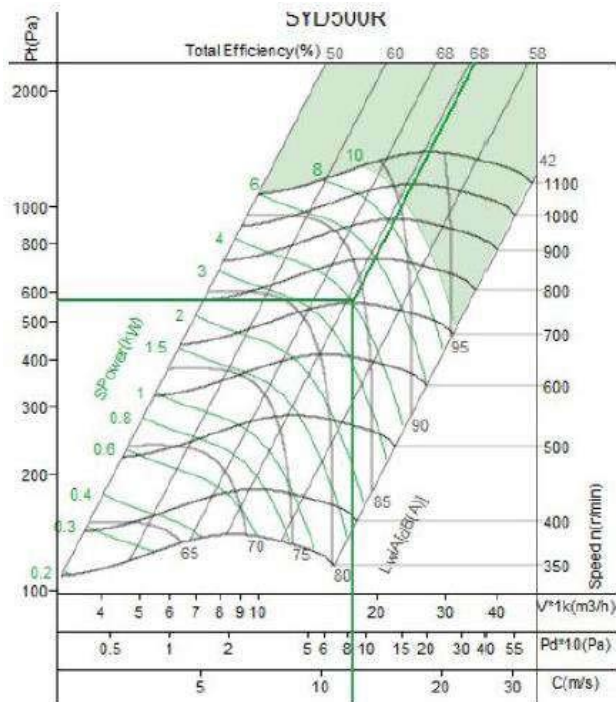

## FASN400

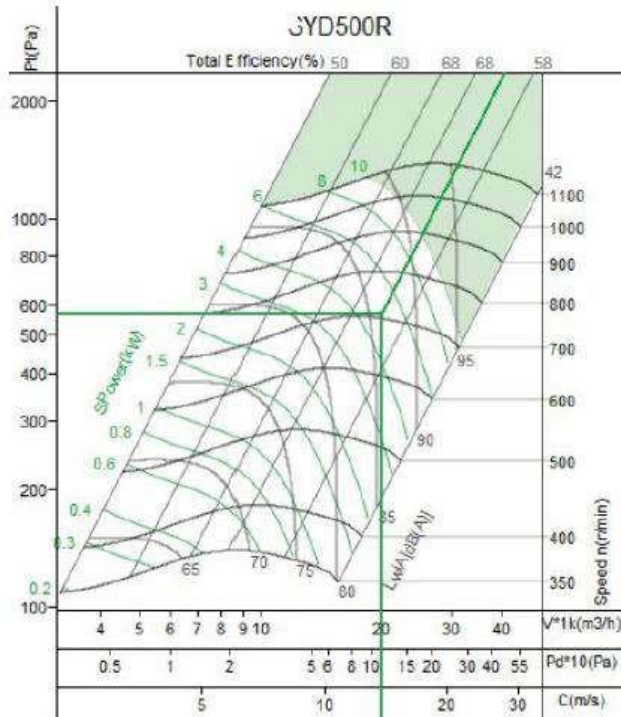

## FASN450

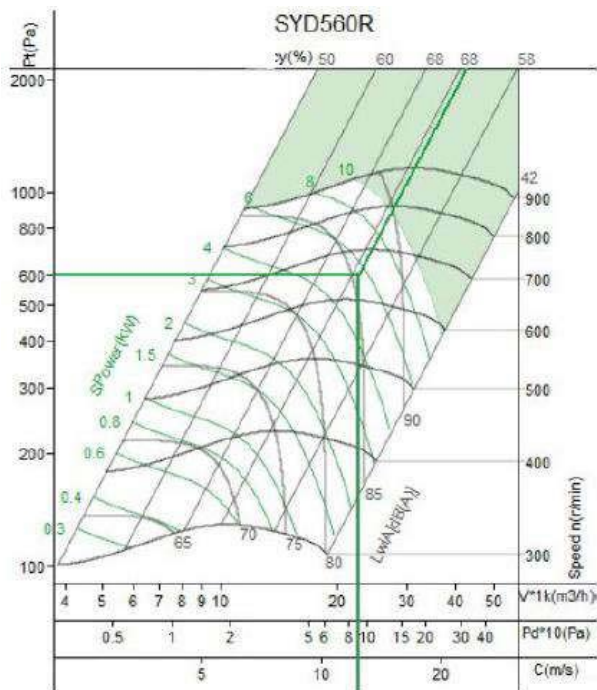

## FASN500

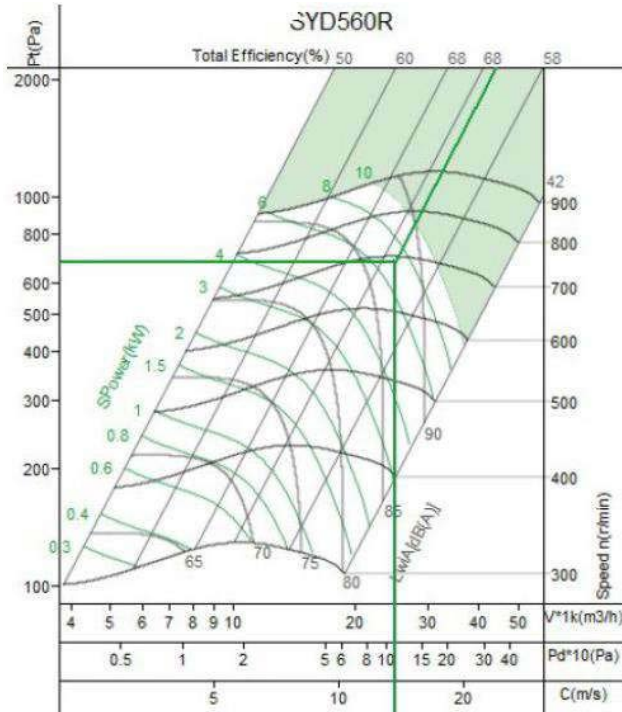

## FASN600

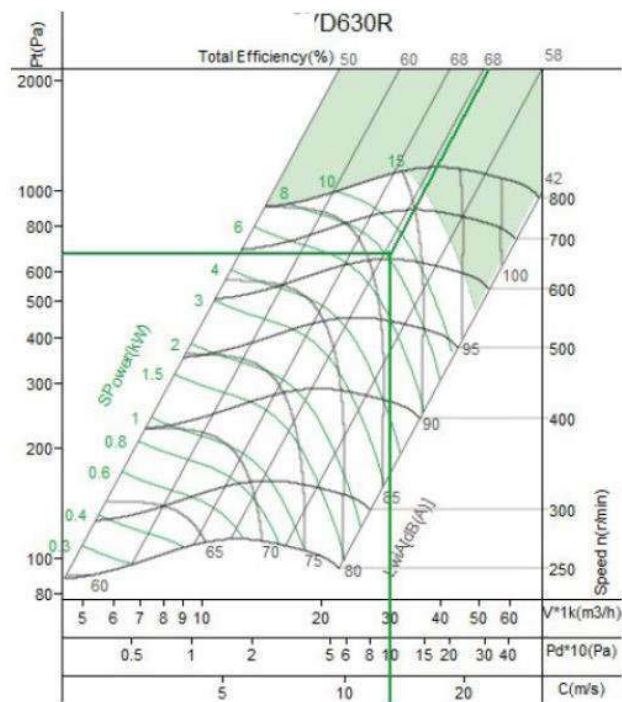

# FASN750

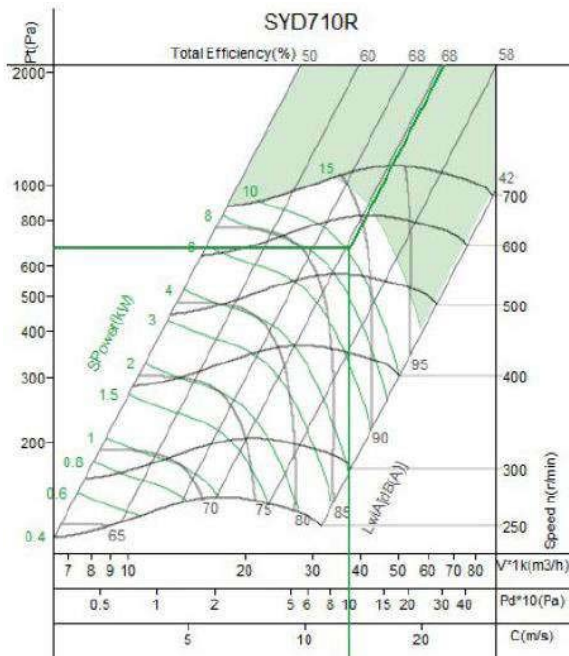

### FASD080

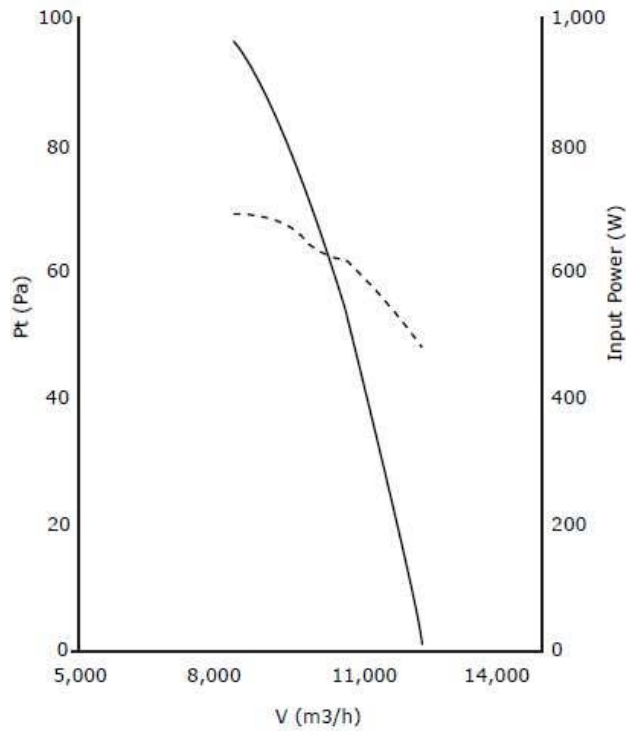

### FASD100

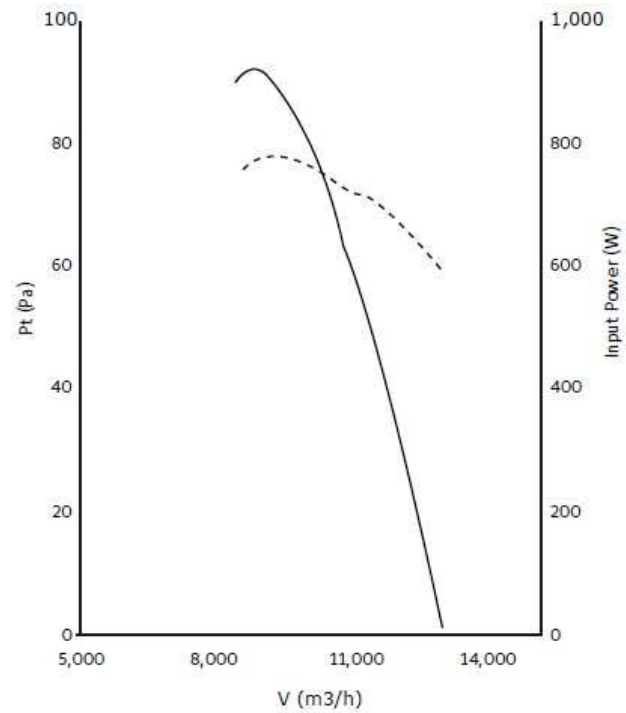



### FASD125

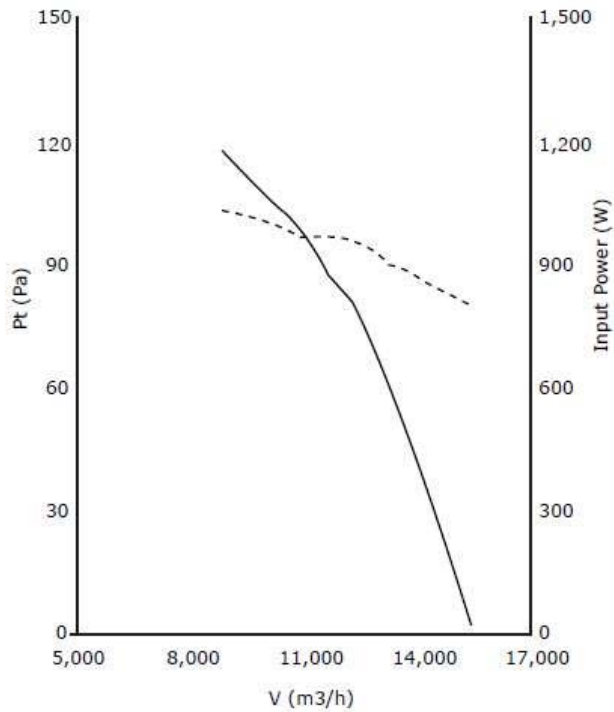

### FASD150

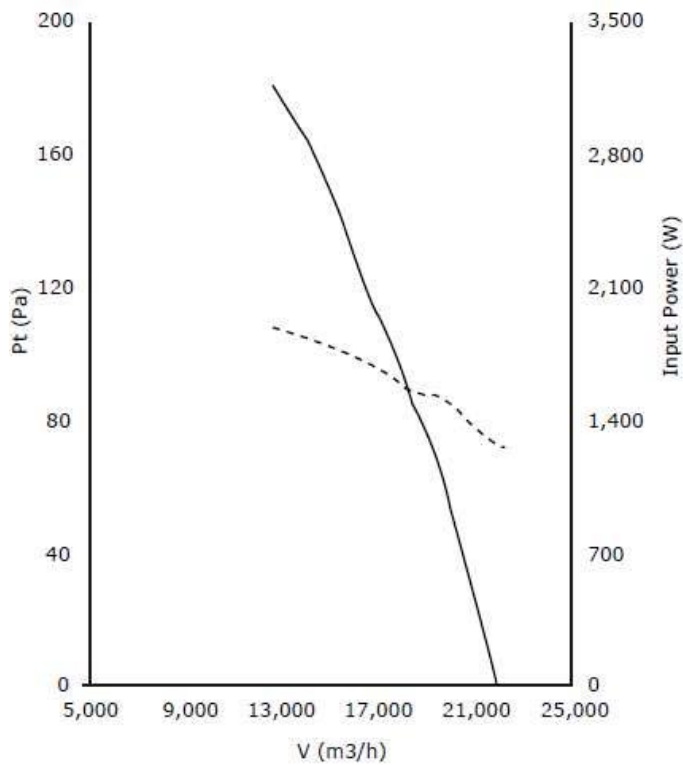

# Dimensions

**Model: FASN080 / 100**

**Top View**

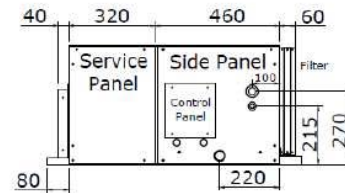
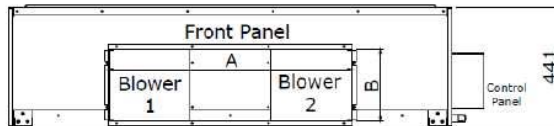
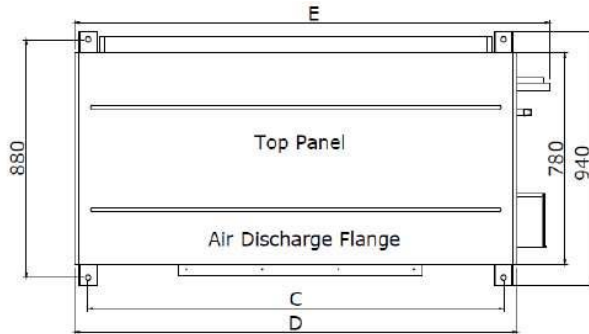

**Front View**

**Side View**

Model	Dimension(mm)				
	A	B	C	D	E
FASN080	783	261	1240	1310	1431
FASN100	903	267	1540	1640	1731

[unit:mm]

**Model: FASN125 / 150**

**Top View**

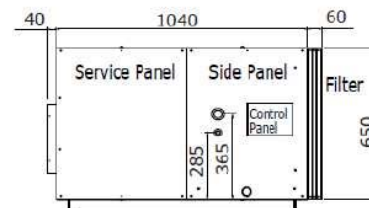
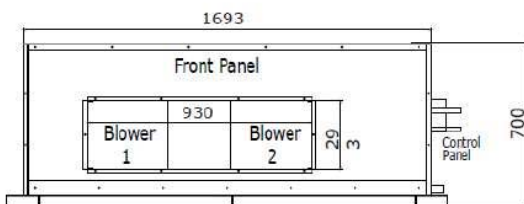
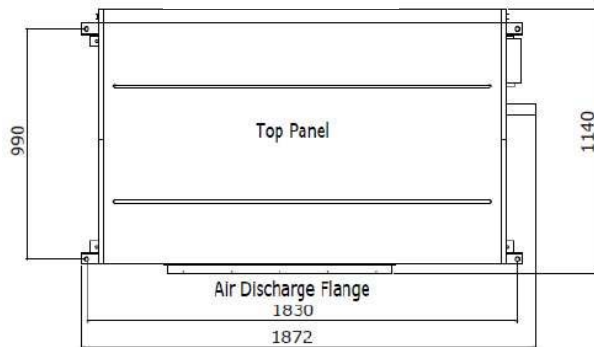

**Front View**

**Side View**

[unit:mm]



**Model: FASN200**

**Top View**

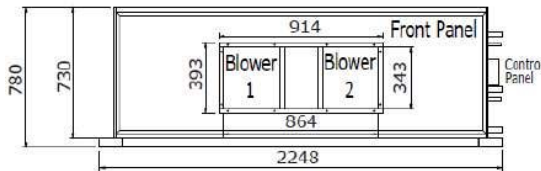
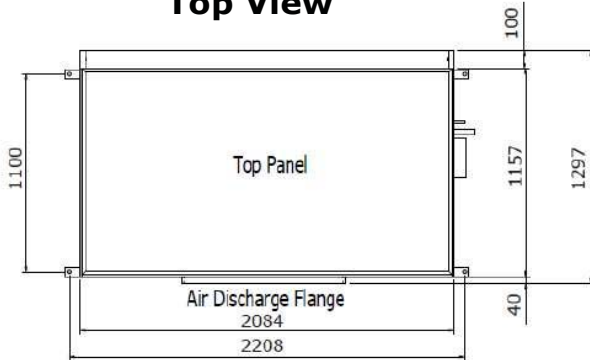

**Front View**

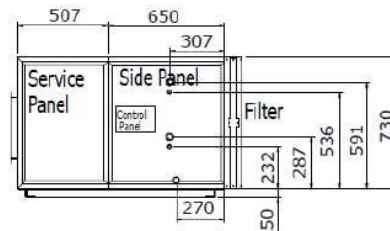

**Side View**

[unit:mm]

**Model: FASN250**

**Top View**

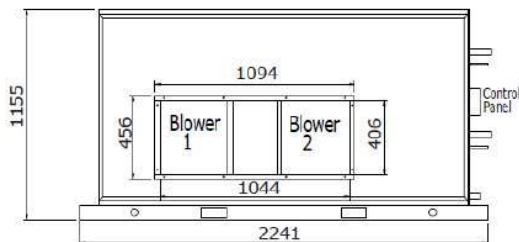
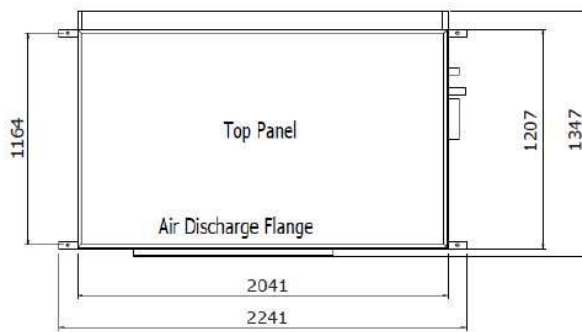

**Front View**

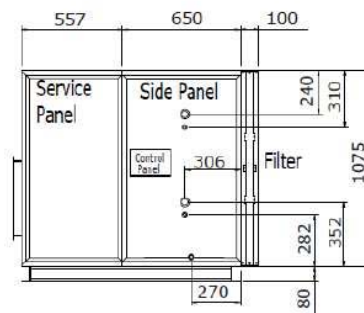

**Side View**

[unit:mm]

**Model: FASN300**

**Top View**

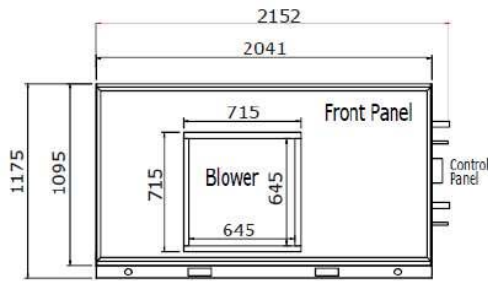
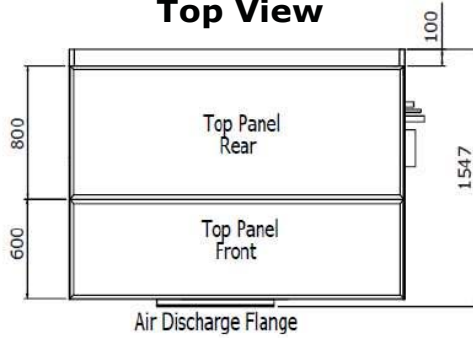

**Front View**

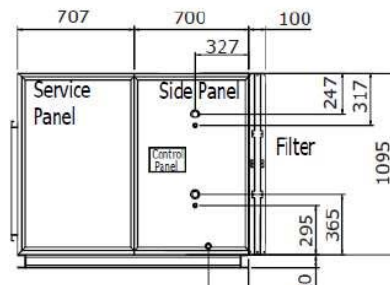

**Side View**

[unit:mm]

**Model: FASN350**

**Top View**

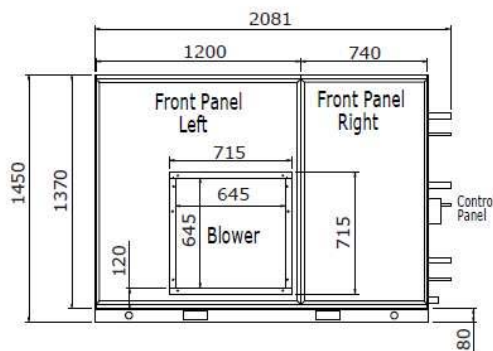
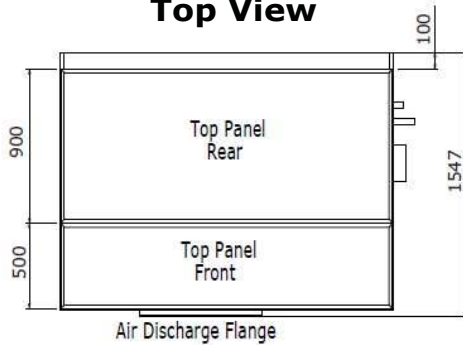

**Front View**

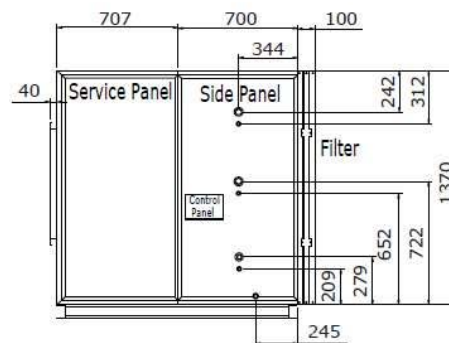

**Side View**

[unit:mm]

**Model: FASN450**

**Top View**

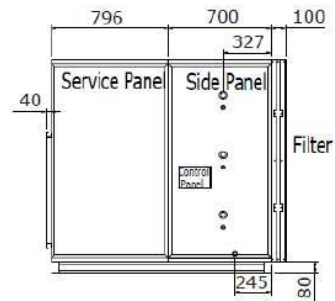
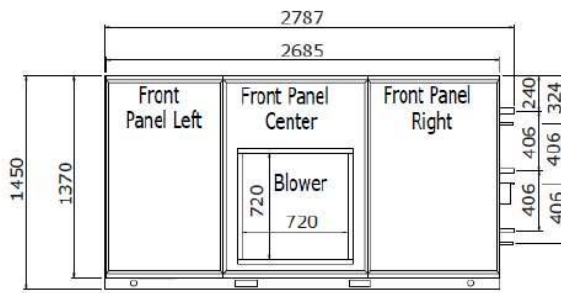
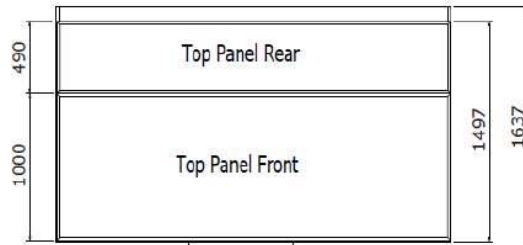

**Front View**

**Side View**

[unit:mm]

**Model: FASN400/500/600**

**Top View**

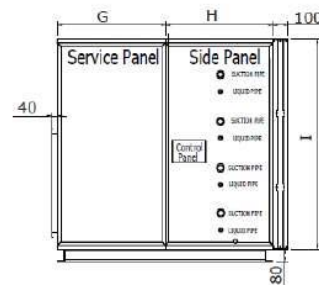
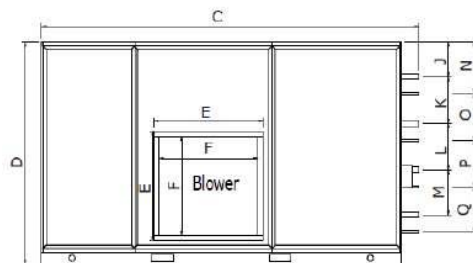
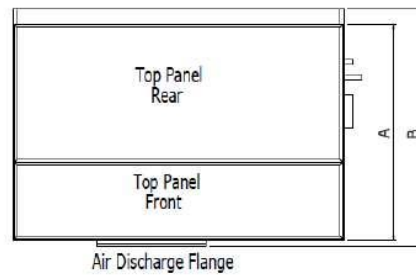

**Front View**

**Side View**

[unit:mm]

Model	Dimension(mm)																
	A	B	C	D	E	F	G	H	I	J	K	L	M	N	O	P	Q
FASN400	1407	1547	2335	1450	715	645	806.5	600	1370	188	305	305	293	298	305	305	293
FASN500	1497	1637	2698	1450	790	720	797	700	1370	188	305	305	293	298	305	305	293
FASN600	1597	1737	2698	1650	880	810	797	800	1570	224	330	356	381	334	330	356	381

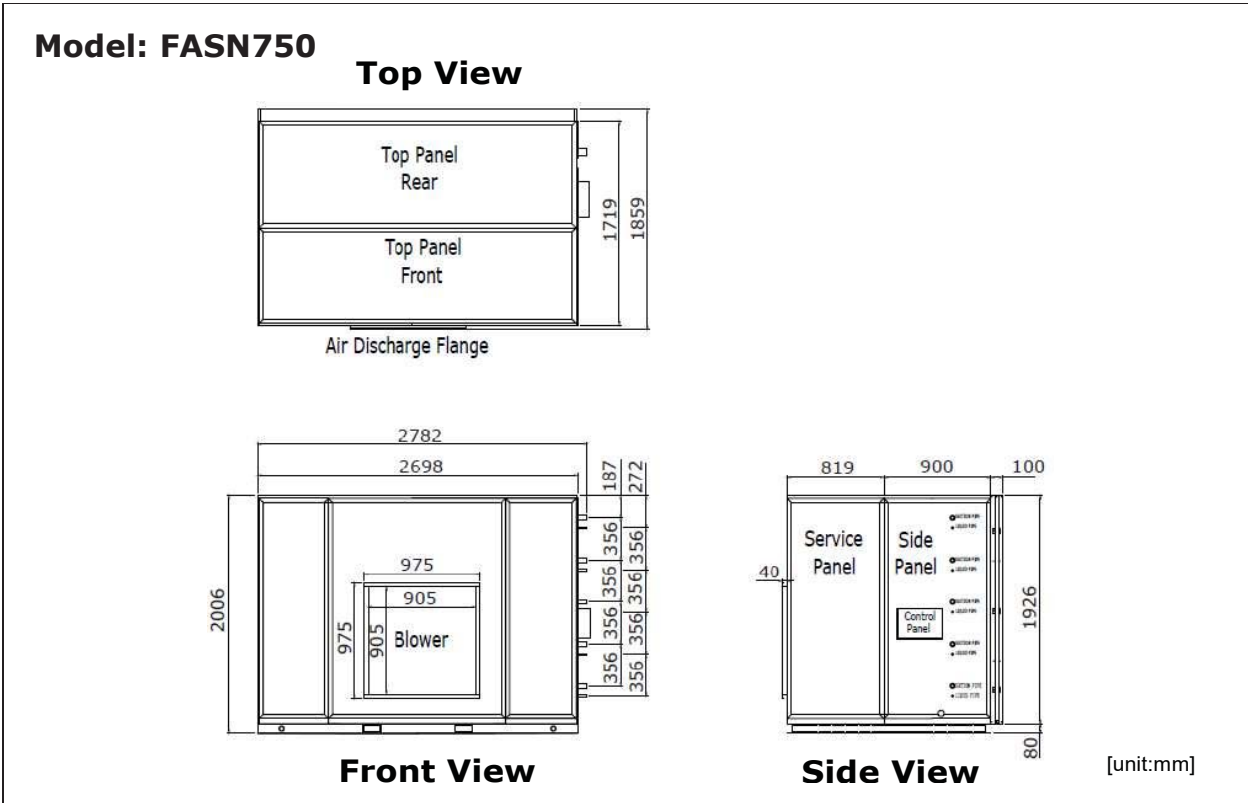

**Model: FASD080**

**Top View**

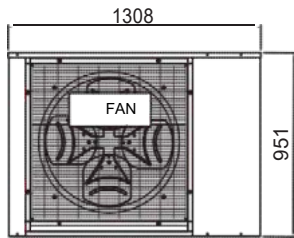
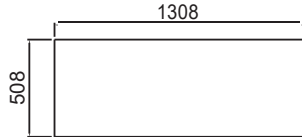

**Front View**

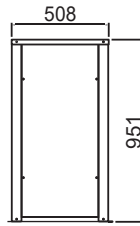

**Side View**

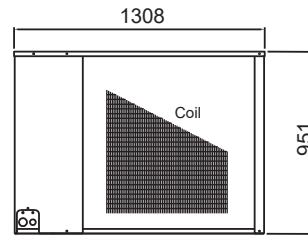

**Back View**

[unit:mm]

**Model: FASD100 / 125 / 150**

**Top View**

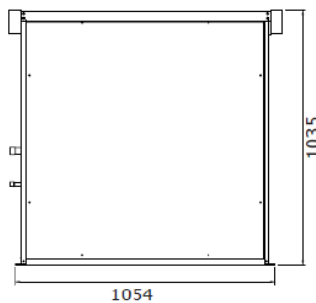
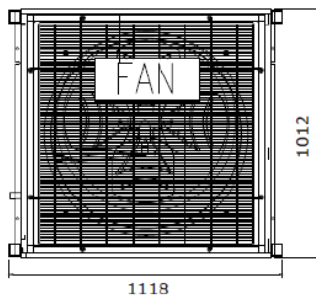

**Front View**

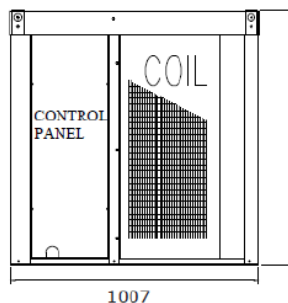

**Side View**

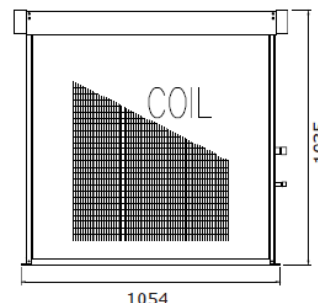

**Back View**

[unit:mm]

# Wiring Diagrams

## Model: FASN080/FASD080 (With Control PCB)

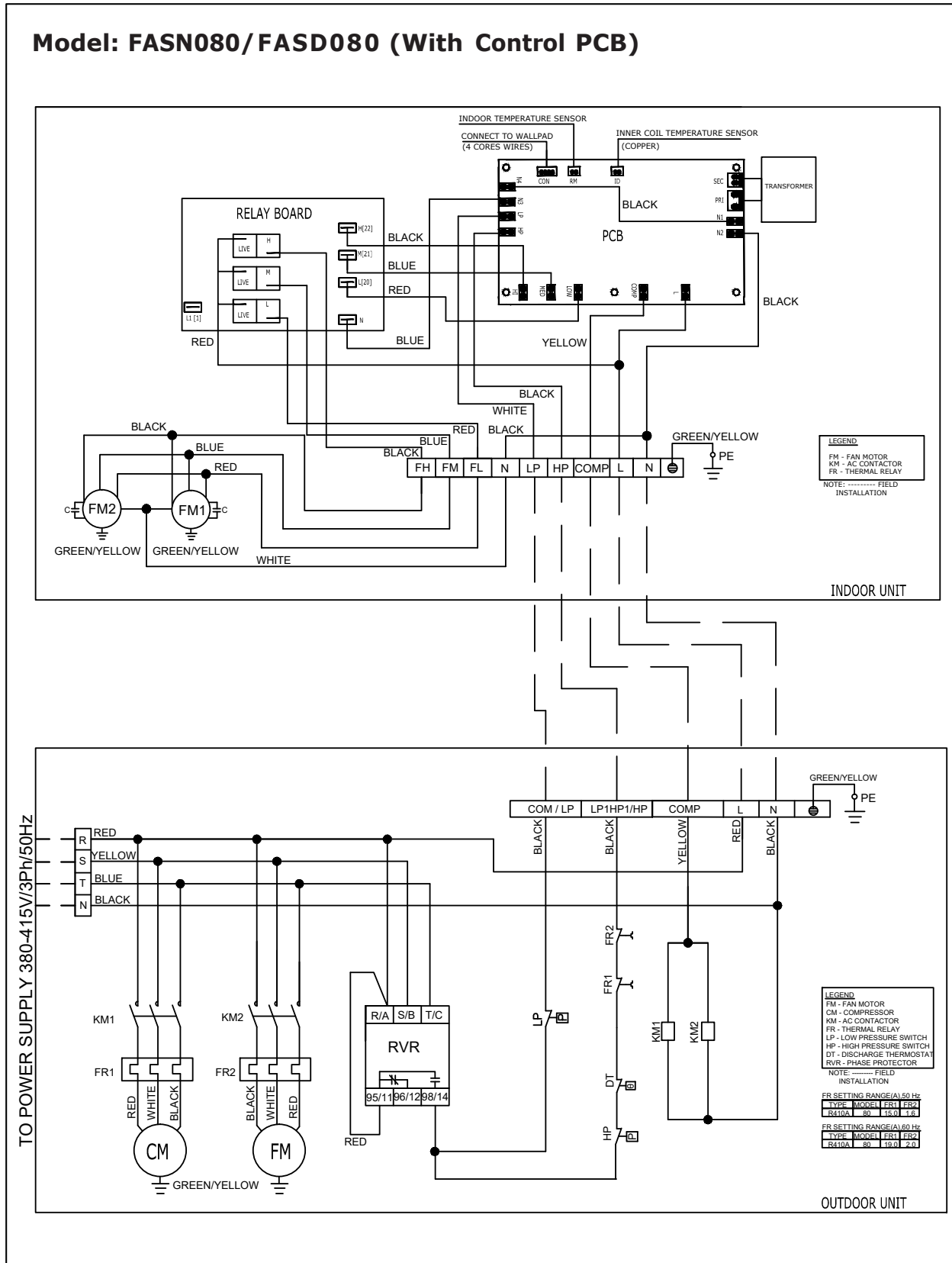

### Model: FASN100/FASD100 (With Control PCB)

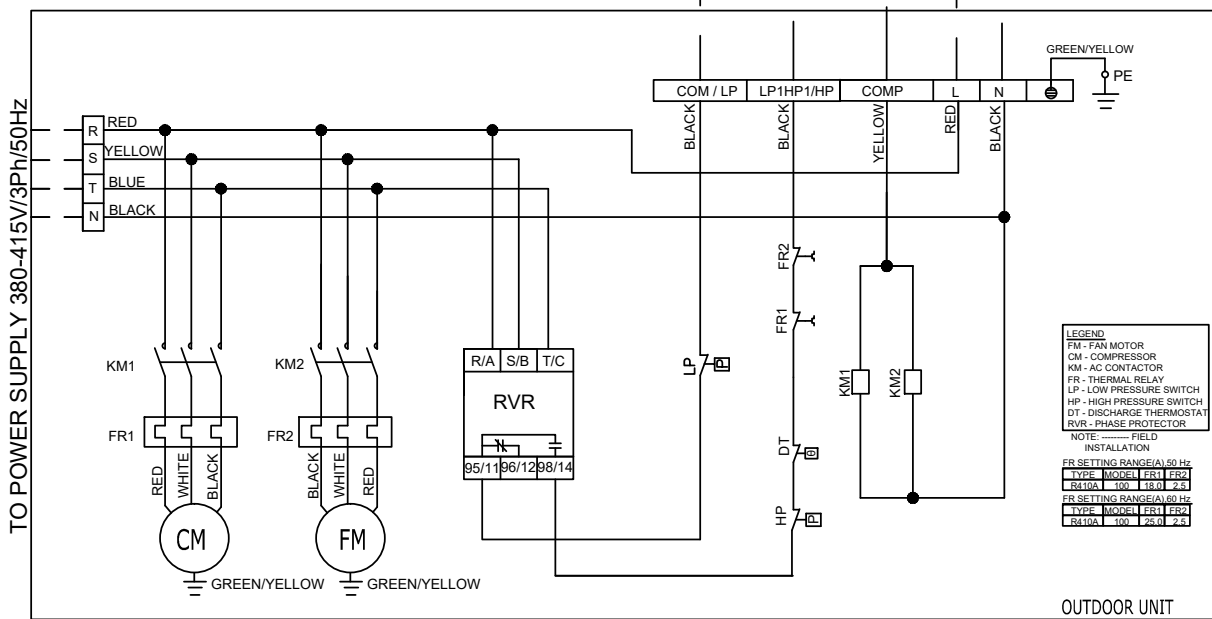
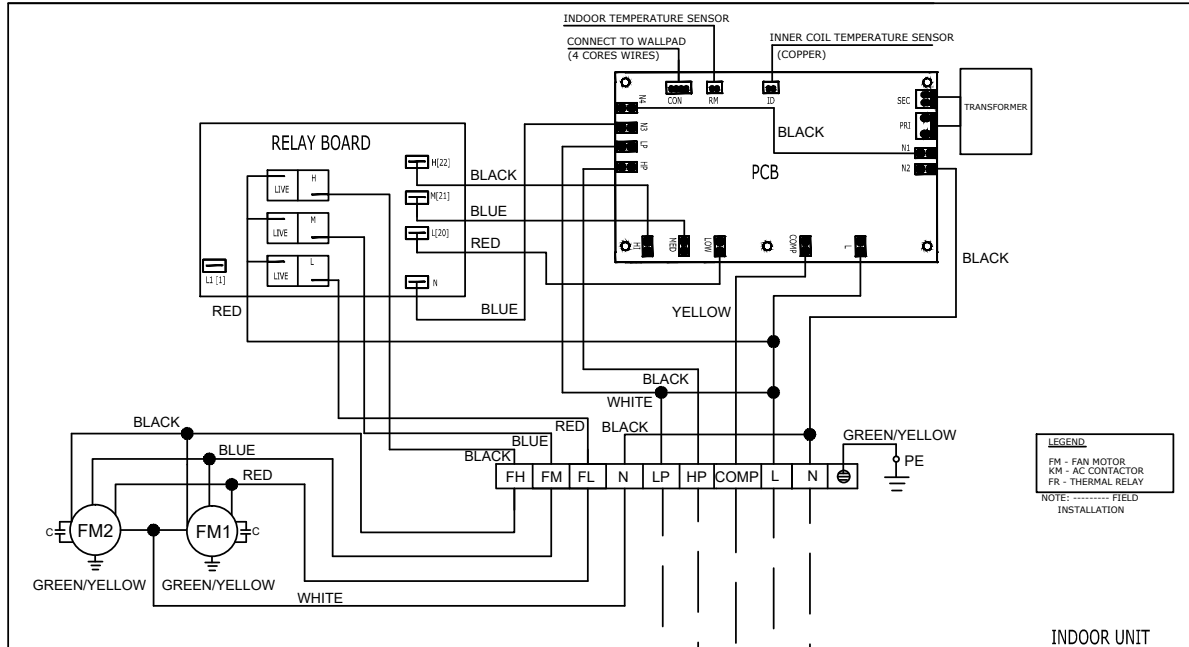

**Model: FASN125/FASD125 (With Control PCB)**  
**FASN150/FASD150 (With Control PCB)**

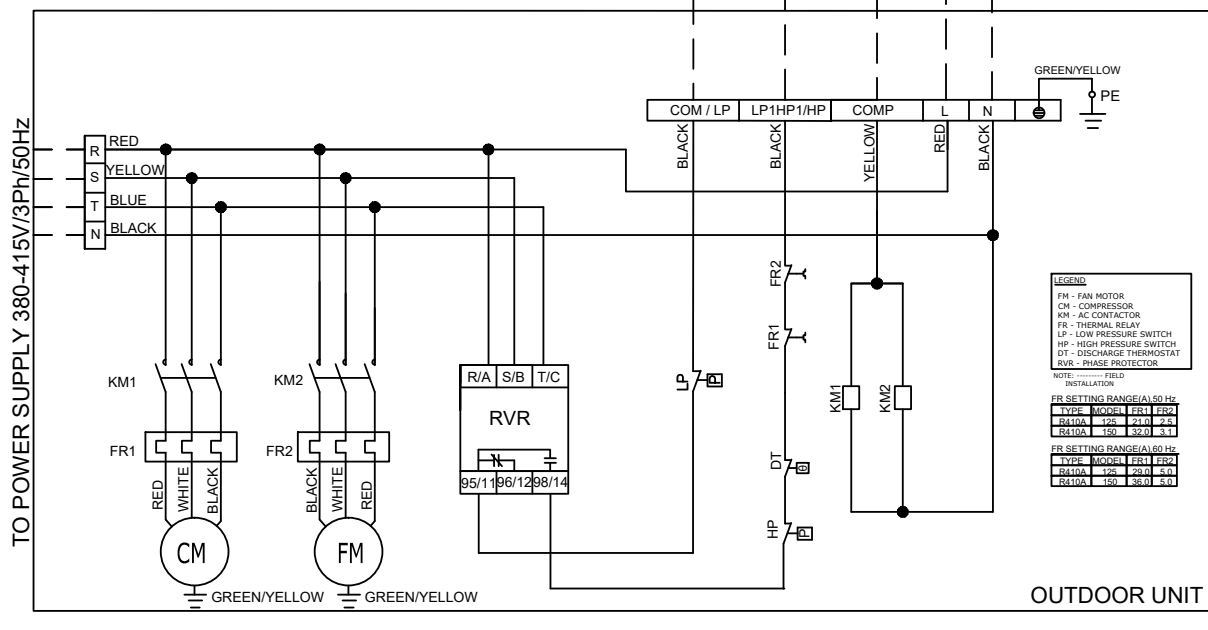
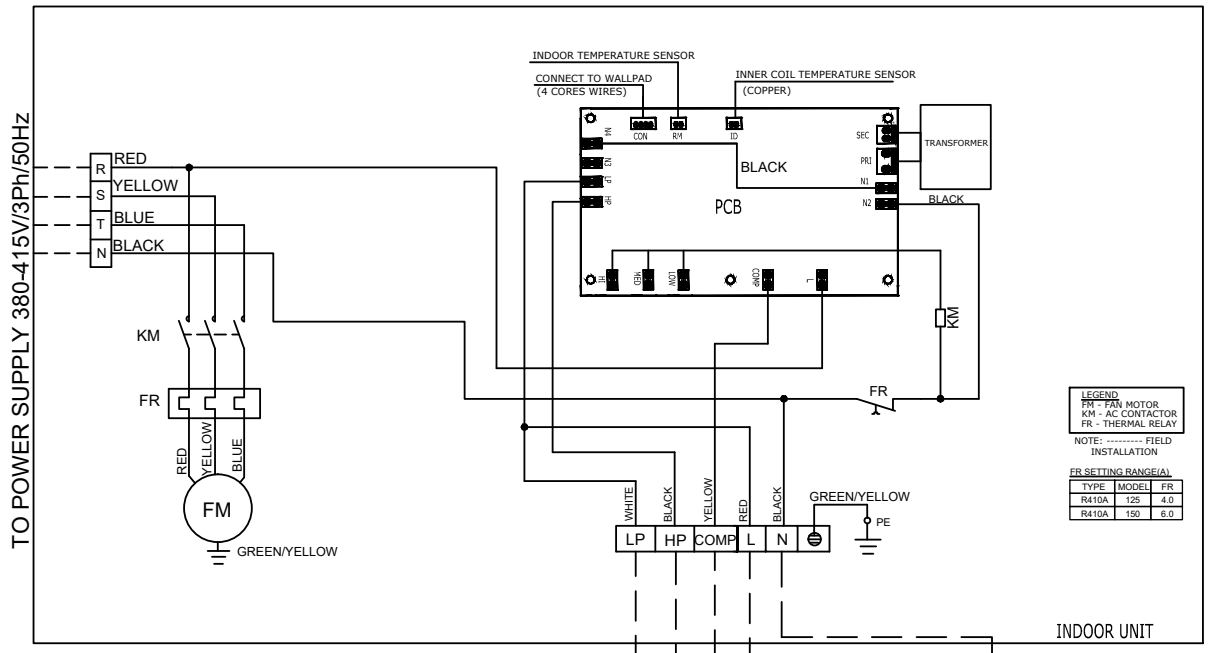



**Model: FASN200/FASD100x2 (With Control PCB)**  
**FASN250/FASD125x2 (With Control PCB)**  
**FASN300/FASD150x2 (With Control PCB)**

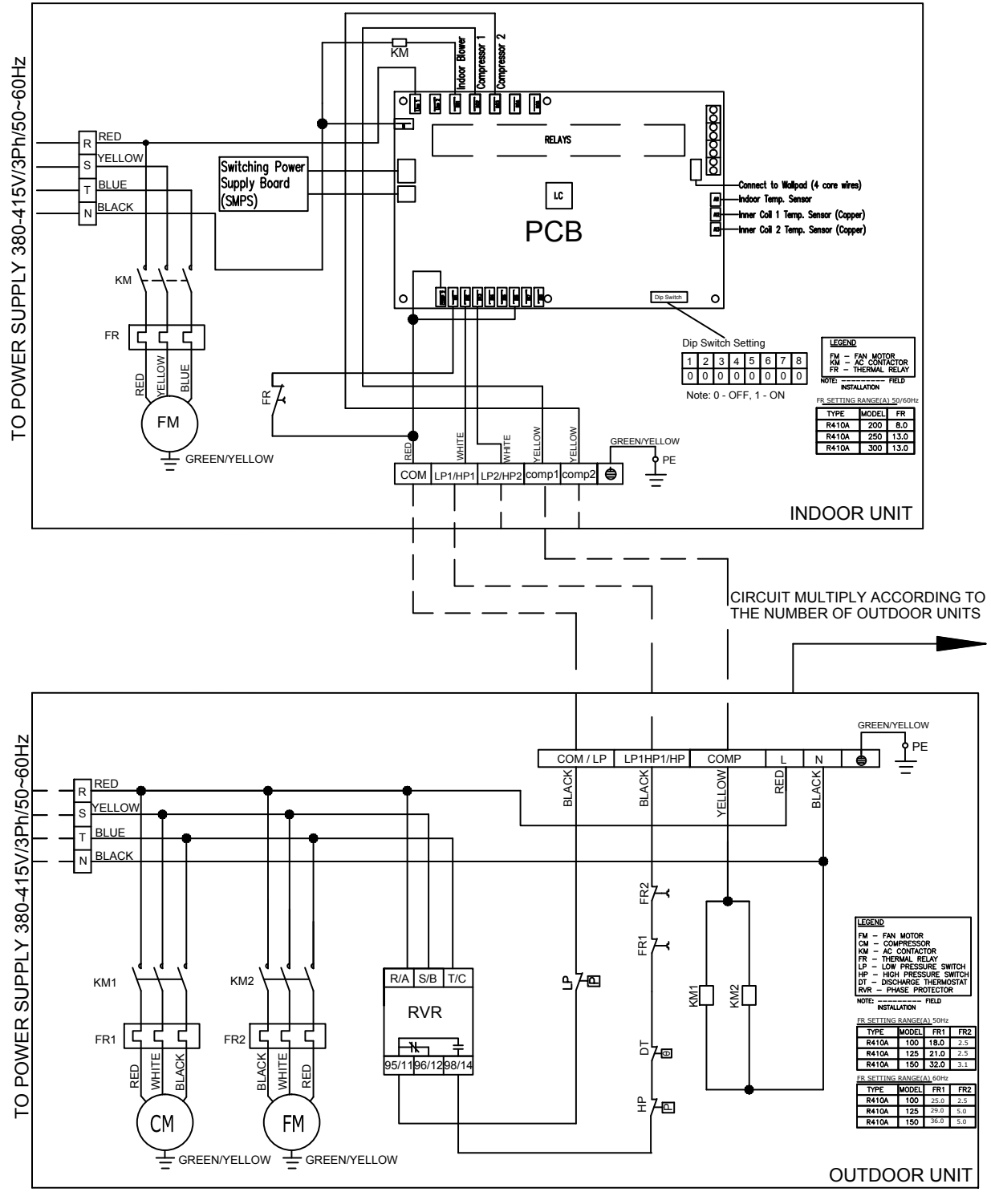

**Model: FASN350/FASD100+FASD125X2 (With Control PCB)  
FASN450/FASD150x3 (With Control PCB)**

TO POWER SUPPLY 380-415V/3Ph/50~60Hz

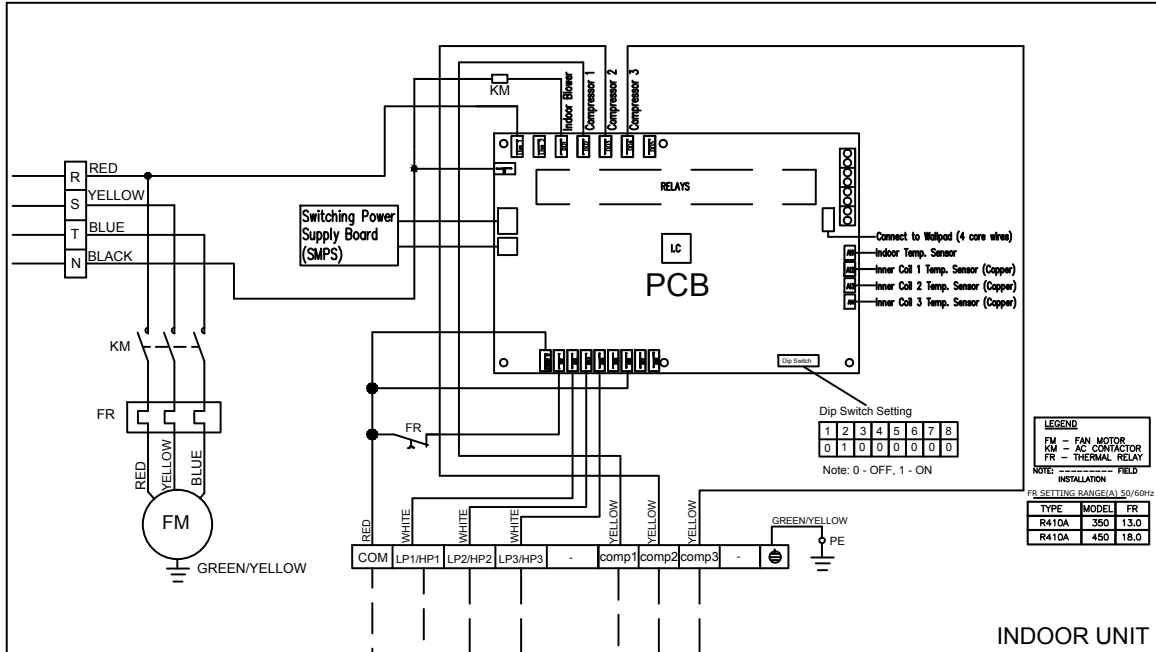

INDOOR UNIT

CIRCUIT MULTIPLY ACCORDING TO THE NUMBER OF OUTDOOR UNITS

TO POWER SUPPLY 380-415V/3Ph/50~60Hz

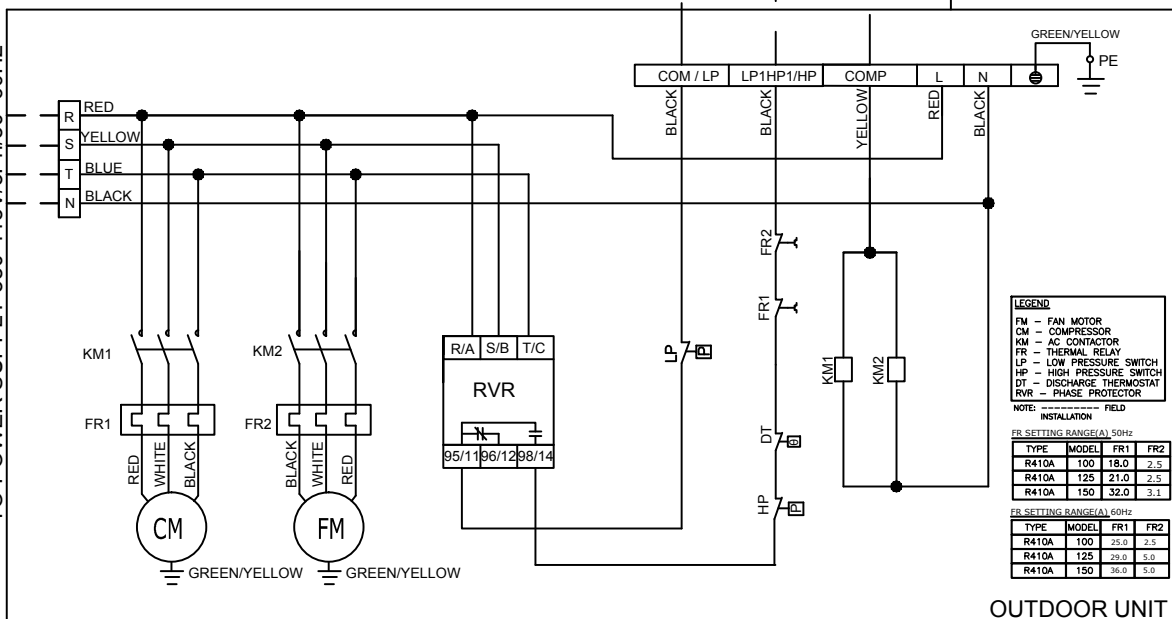

OUTDOOR UNIT

### Model: FASN400/FASD100x4 (With Control PCB)

TO POWER SUPPLY 380-415V/3Ph/50~60Hz

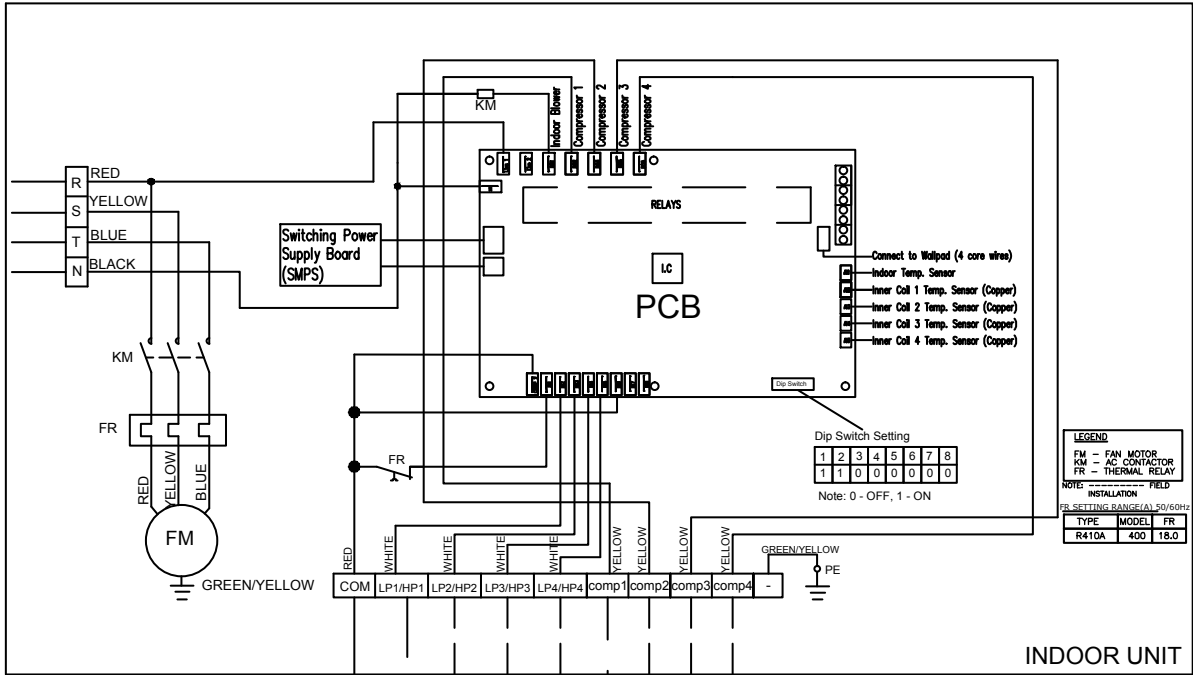

CIRCUIT MULTIPLY ACCORDING TO THE NUMBER OF OUTDOOR UNITS

TO POWER SUPPLY 380-415V/3Ph/50~60Hz

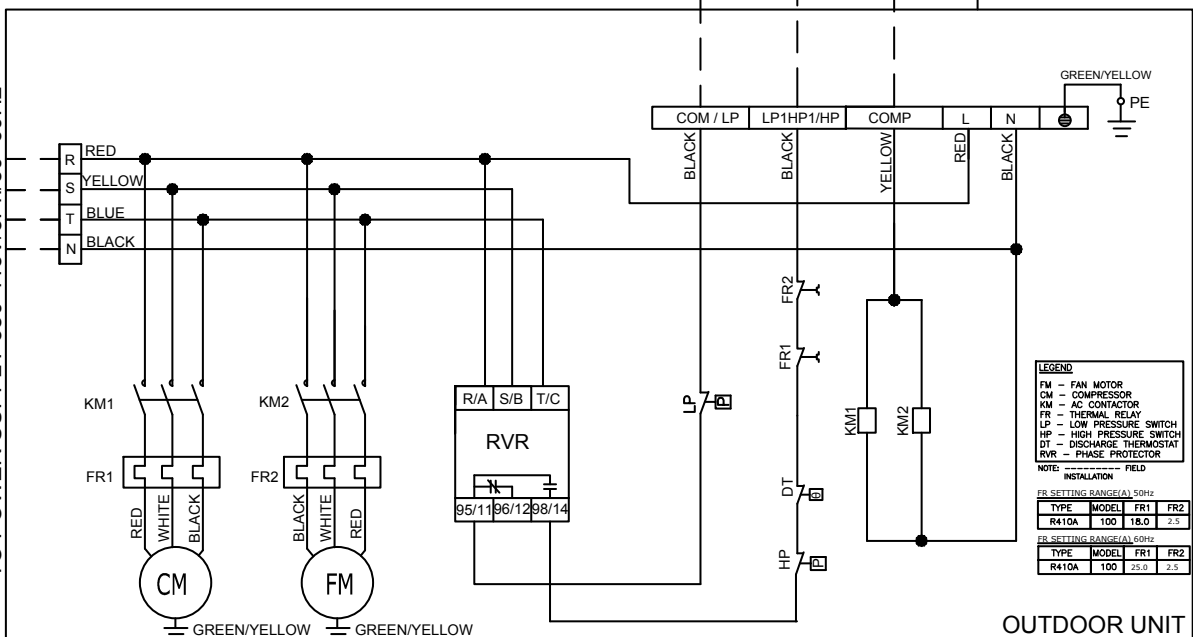

**Model: FASN500/FASD125x4 (With Control PCB)**  
**FASN600/FASD150x4 (With Control PCB)**

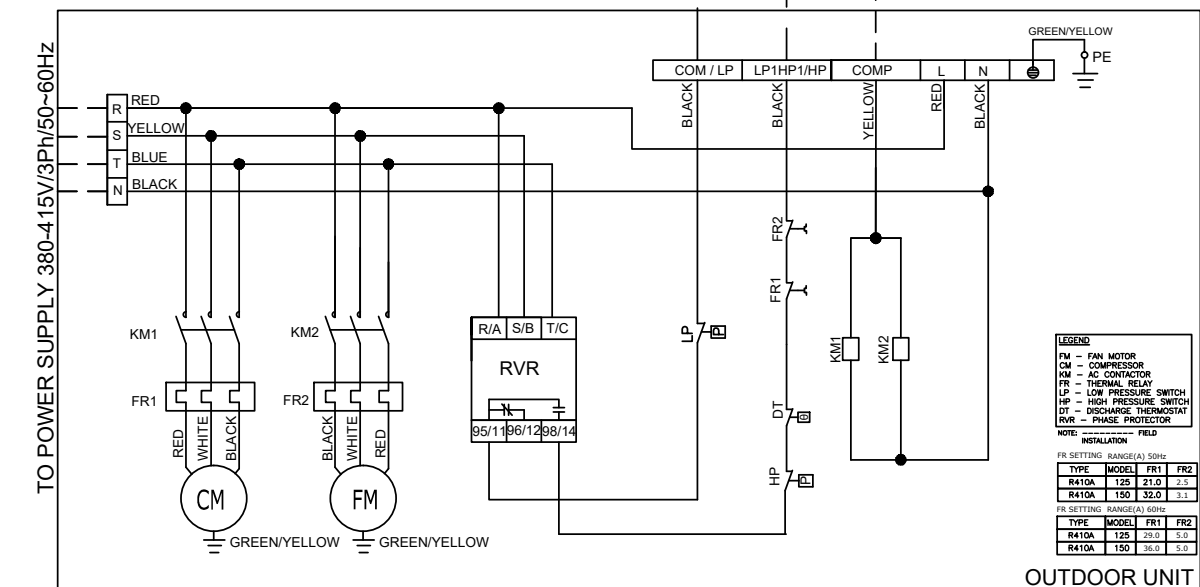
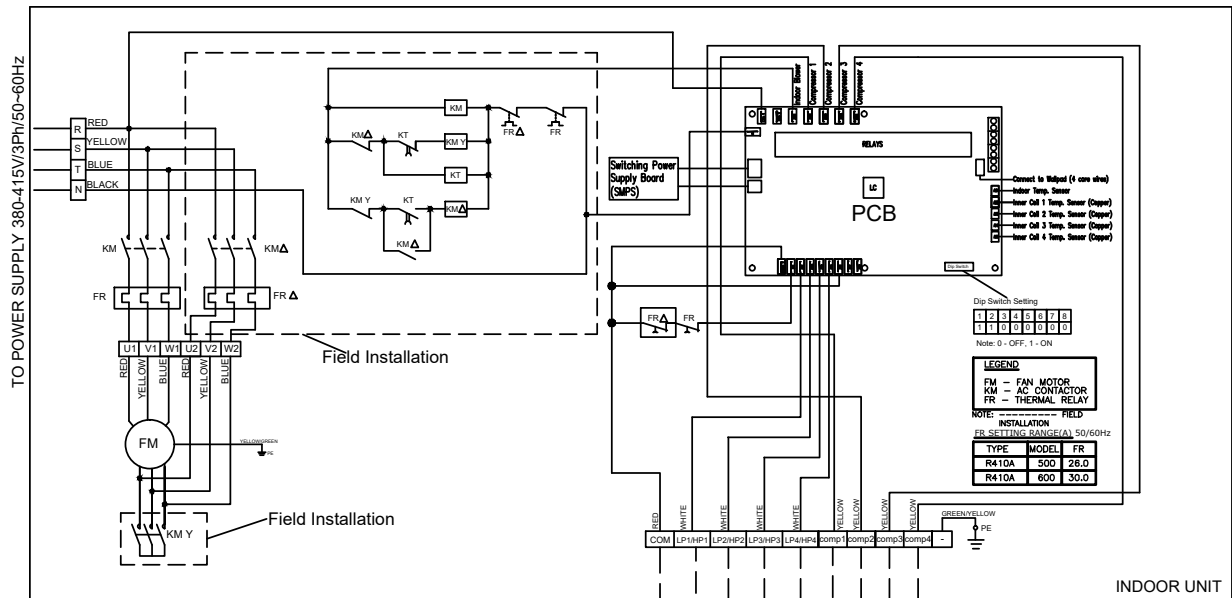

# Model: FASN750/FASD150x5 (With Control PCB)

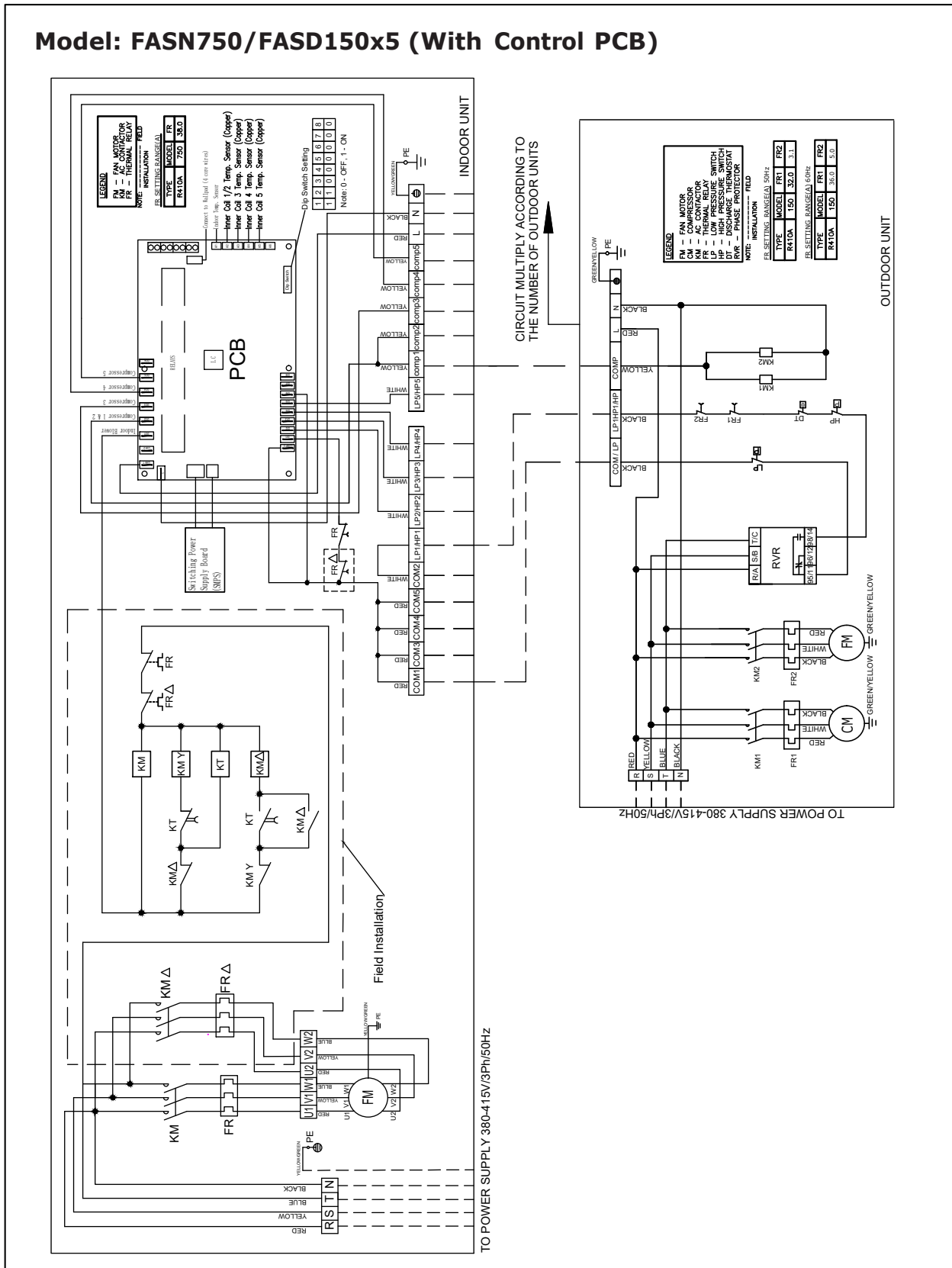

**Model: FASN080/100 (Without Control PCB)**

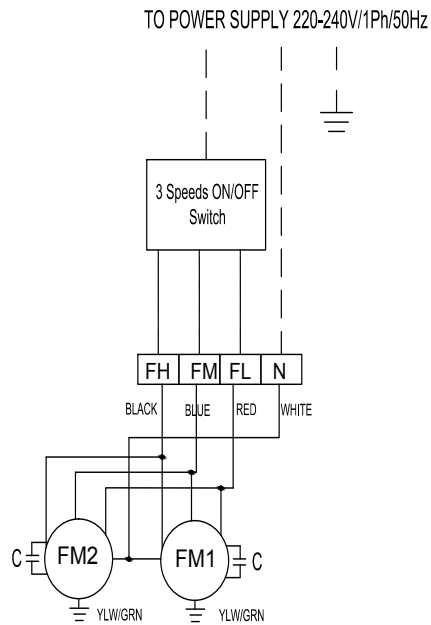

Note: - - - - - installation connection

**Model: FASN125/150/200/250/300/350/400/450  
(Without Control PCB)**

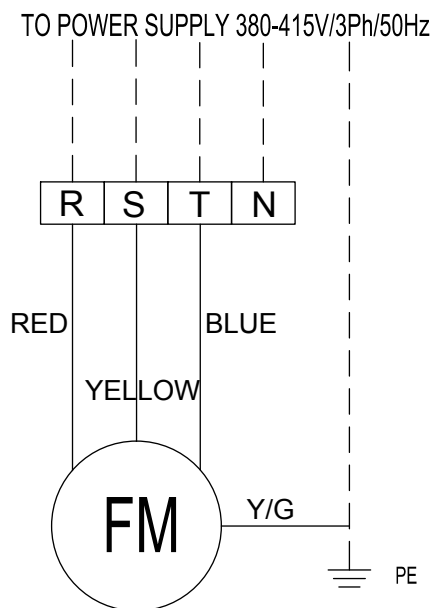

Note: - - - - - installation connection

**Model: FASN500/600/750 (Without Control PCB)**

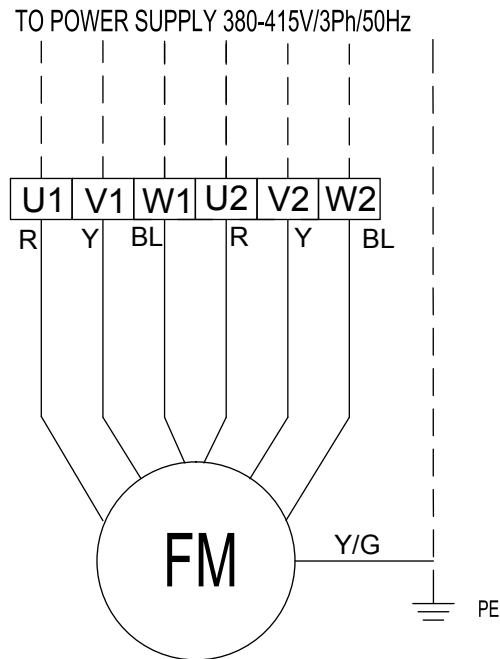

Note: - - - - - installation connection

**Model: FASD080/100/125/150 (Without Control PCB)**

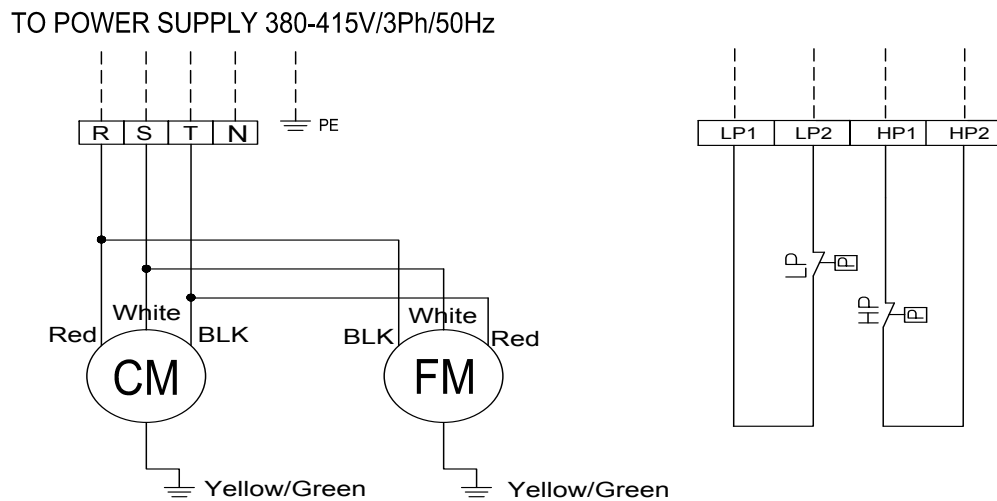

Note: - - - - - installation connection

---

# Installation

---

Unit should be installed by qualified technicians. Installation should adhere to local code and regulations.

## **Warning:**

Please pay attention to the following:

- Please check the equipment with your check list after receiving the unit.
- Please keep the unit horizontal and balanced before hanging up the unit.
- Please ensure proper equipment (e.g., fork lift, hoist, sling, etc.) is used when handling the unit.
- Please remove all packaging material after installation.

If there are any problems or the unit is damaged, please contact authorized dealer.

## 1. Indoor Unit Installation

Carefully plan the installation location with the following considerations:

- Easy distribution of air ducts.
- Space for connection of refrigerant pipes, wirings and water pipes.
- Ceiling/structure is strong enough to support the unit.
- For noise consideration, always install unit away from air-conditioned area.
- Always allow sufficient space for servicing and maintenance as shown in the following diagram:

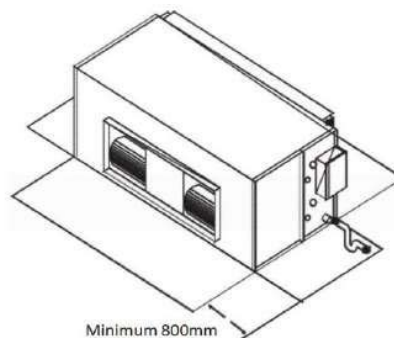

- Use the hanging rods to hang the unit through the holes provided. Strength of hanging rods must be able to support the total weight of the unit.
- During operation of the unit, there will be plenty of condensate water that needs to be discharged. In order to prevent overflow of condensate water, the water must be drained through condensate water pipe. Please ensure a gradient is maintained as shown in the following diagram.



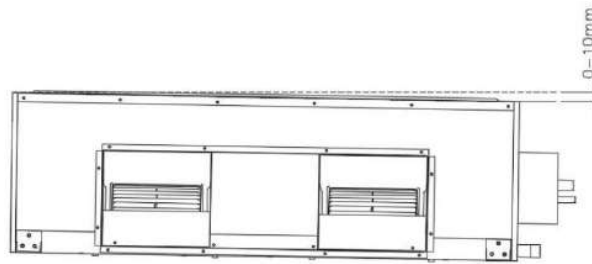

- To reduce noise transmission through hanging rod, it is recommended to install rubber dampers or isolators.
- Muffler can be used to reduce noise transmission through air duct if the unit needs to be installed near air-conditioned area.

### Condensate drain pipe installation:

- For easy drainage of condensate water, drain pipe must be sloped downward at least at a gradient of 1:100.
- The drain pipe must have a U-bend.
- Drain pipe that runs under the ceiling or within the air-conditioned space should be insulated to prevent condensation of water. Choice of insulation material can be PE, PU or other appropriate insulation material.

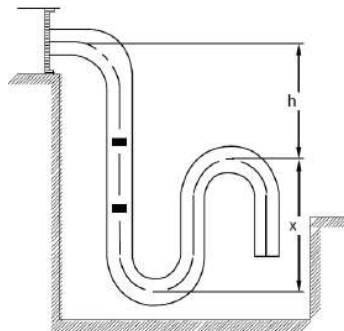

### Air Ducting Installation:

- There are two types of discharge air-duct, namely rectangular and round ducts.
- Rectangular ducts can be connected to the discharge of the indoor unit directly. Refer to the dimension drawing of the unit to see the dimensions of the discharge.
- Flexible connection must be installed between air ducts and indoor unit to ensure quiet operation.
- A reducer is necessary to connect the round duct to the discharge of the unit.
- Design of supply and return air duct should strictly adhere to the maximum static pressure that can be delivered by the unit to avoid unsatisfactory unit performance and overload of fan motors.

## 2. Outdoor Unit Installation

To ensure the unit operates at optimum performance level and to maintain long life-span of components, the choice of location of unit and installation recommendations as listed below should be followed:

- The discharge air and intake air direction of outdoor unit should not be blocked to ensure there is no short circuiting of hot air.
- If there is more than 1 unit being installed at the same location, make sure that the discharge of one unit does not face the air intake of another.
- The location of installation should be well ventilated and avoid direct sunlight.
- Location of installation should be able to drain rain water or condensation water.
- Ensure the location of installation does not face strong wind and is free from dust.
- Do not connect duct to the outdoor fan discharge.
- Do not install the unit at location that is near corrosive materials or chemicals.
- Avoid installing the outdoor unit under the window.
- Ensure the discharge of air and noise generated during operation do not affect the surrounding neighbors.

### Installation Clearance:

To provide sufficient service clearance and to ensure good air intake and discharge, please refer to the recommendation as follows:

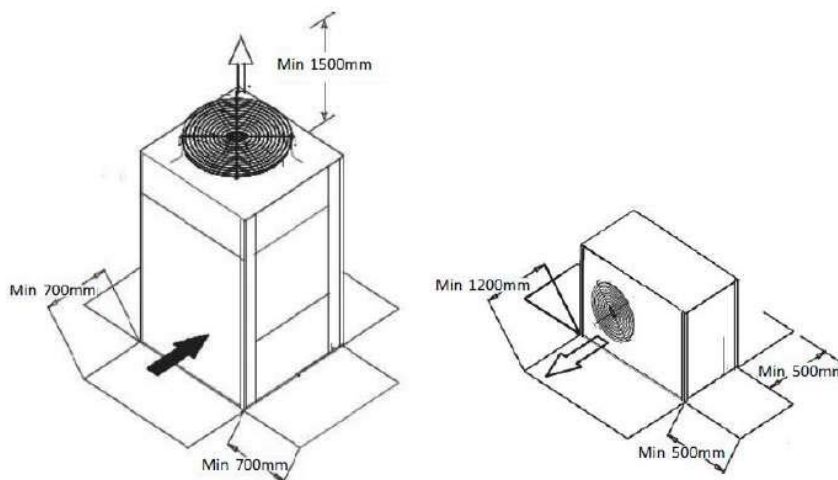

## Refrigerant Piping

Long refrigerant piping will affect the performance of the unit and shorten the lifespan of compressor. In the worst-case scenario, it will cause the compressor to break down. Special precaution needs to be taken to make sure that the maximum length of the piping strictly adheres to the recommended maximum pipe length and elevation in the following tables:

Model		Maximum Length(m)	Maximum Elevation (m)	Maximum Bends
FASN080	FASD080	35	20	8
FASN100	FASD100	35	20	8
FASN125	FASD125	35	20	8
FASN150	FASD150	35	20	8
FASN200	FASD100x2	35	20	8
FASN250	FASD125x2	35	20	8
FASN300	FASD150x2	35	20	8
FASN350	FASD100 + FASD125x2	35	20	8
FASN400	FASD100x4	35	20	8
FASN450	FASD150x3	35	20	8
FASN500	FASD125x4	35	20	8
FASN600	FASD150x4	35	20	8
FASN750	FASD150x5	35	20	8

### CAUTION:

- 1. Our guarantee on the performance of our air-conditioners is strictly revoked if the height and/or length of the refrigerant piping system installed is beyond the limit above.**
- 2. Bending must be carefully made so as not to crush the pipe. Use pipe bender bend a pipe as far as possible.**

## Vacuuming and Refrigerant Charging

Vacuuming is necessary to eliminate all moisture and air from the system.

### Vacuuming

After the system piping is properly connected, vacuum the air conditioner system to at least 500 microns Hg.

### Charging

Before charging, the vacuum must be held at 500 microns Hg for at least 15 minutes. After charging, operate the unit for 15 minutes, ensuring that refrigerant charges are of correct quantity by monitoring running current and suction and liquid line pressures. Suction and discharge pipe pressures should be in the region of 75 psig and 275 psig. After ensuring the system is correctly charged, remove flexible hose from charging nipples and replace with caps.

## **Additional Charging**

If the piping length is exceeding 10m, additional charge is necessary. The value of additional refrigerant charge (g) per 1 meter is as table below.

<b>Outdoor Model</b>	FASD080	FASD100	FASD125	FASD150
<b>Add. Charge, g/m</b>	78.0	105.0	118.5	145.5

Note: Failure to add proper amount of additional refrigerant may result in reduced performance.

### **Attention:**

Outdoor unit is not factory pre-charged with refrigerant.

## Lifting Method

Each product design to be brought in safety. When the unit is to be lifted and moved, attach ropes to the suspension plates(4pcs) provided on the top of the unit. When the unit is lifted, the center of gravity tends to shift the unit to one side and so balance as shown in the figure below should be achieved. The angles at which the ropes suspended the unit should be at least  $60^\circ$  at the compressor end and at least  $45^\circ$  at the condenser end. Care should be taken to avoid contact with the main unit while carrying. Hook as directly aligned over the center of gravity as possible.

### Example for the indoor unit shown as figure:

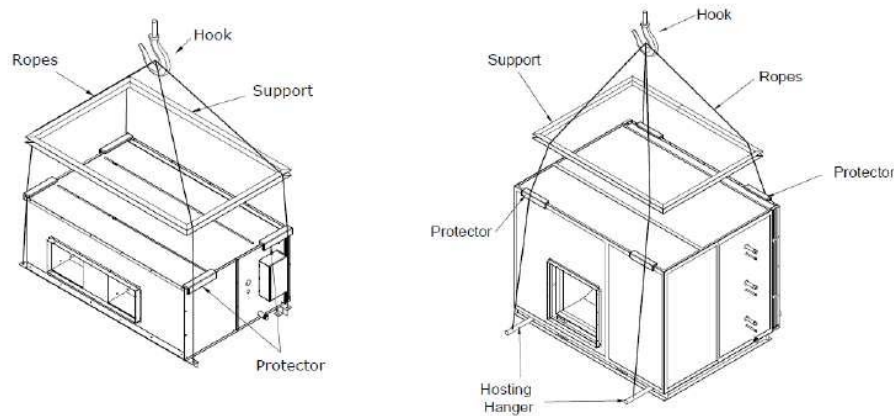

### Example for the outdoor unit shown as figure:

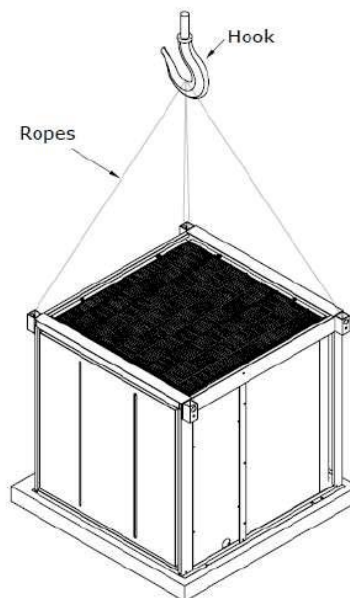

---

# Servicing and Maintenance

---

## 1. Indoor Unit

### Air Filter

- The filter must be cleaned regularly and the frequency of cleaning is to be determined by the degree of pollution of the environment of application. When washing the filter, first tap it gently to remove larger particle, and then rinse the filter in detergent and warm water. The filter must be dried before it is used. The filter is recommended to be installed before the air grille or the indoor coil. If there are any problems or the unit is damaged, please contact authorized dealer.

### Motor

- It is not necessary to lubricate the motor for servicing and maintenance.

### Heat Exchanger

- After in use for a while, the surface of the coil may collect dust, dirt or other undesirable substances. It is recommended to clean the aluminum fins of the coil using a nylon brush or vacuum cleaner. If compressed air is available, it can be used to clean the coil by direct blowing. However, care must be taken not to damage the fins.

### Drain Pipe

- Check the drain pipe regularly to prevent blockages by alien substances.

## 2. Outdoor Unit

Under normal operating conditions, outdoor unit should be checked quarterly and the coil surface should be washed. If the outdoor unit is installed at location which is oily, smoky and dusty, regular service should be done by a technician to make sure that the heat exchanger is always in optimum condition.

### **Warning!**

**Do not use oxygen, acetylene, poisonous gas or other gas that will cause explosion under high temperatures and pressure for leak checking. Instead, use nitrogen or R410A for air leakage test.**

## Troubleshooting

Fault	Possible Cause	Solution
Abnormal Noise	Blower blade or blower shaft loose.	Tighten the shaft.
	Blower or blower housing dirty.	Clean blower.
	Duct or modulating valve loose.	Repair duct and modulating valve.
	Fan belts not align or loose.	Align or tighten fan belt.
	Nuts and bolts for motor, fan or motor base loose.	Tighten the nuts and bolts.
	Flexible duct at intake / discharge too tight.	Re-adjust the flexible duct. Change if necessary.
	Fan operating point is not optimum.	Re-select fan motor or pulley.
	Lubrication is bad or no lubrication.	Clean the bearing and re-apply lubrication oil.
	Deflector too small or duct elbow over turn to produce noise.	Change deflector.
	Fan too small.	Reselect fan.
Supply Air Too Low	Dirty filter.	Clean or change filter.
	Leakage in duct.	Check and seal the leakage.
	Air duct is blocked or air vent is not open.	Clear the air duct or open the air vent.
	Fan rotates in wrong direction.	Reverse the phase of power supply.
	RPM too low.	Change fan motor or pulley.
	Fan or fan motor undersized.	Change fan motor or pulleys.
Supply Air Too High	Oversized fan or motor.	Reselect fan motor or pulley.
	RPM too high.	Change fan motor or pulleys.
Air Velocity Too High	Air velocity too high at vent.	Extend vent area.
	Airflow unstable.	Change vent size or add extra deflector to rectify airflow.
Insufficient Fresh Air	Not enough fresh air supply.	Fully open fresh air vent.
		Clean fresh air filter.
		Increase cross-section area of fresh air duct.

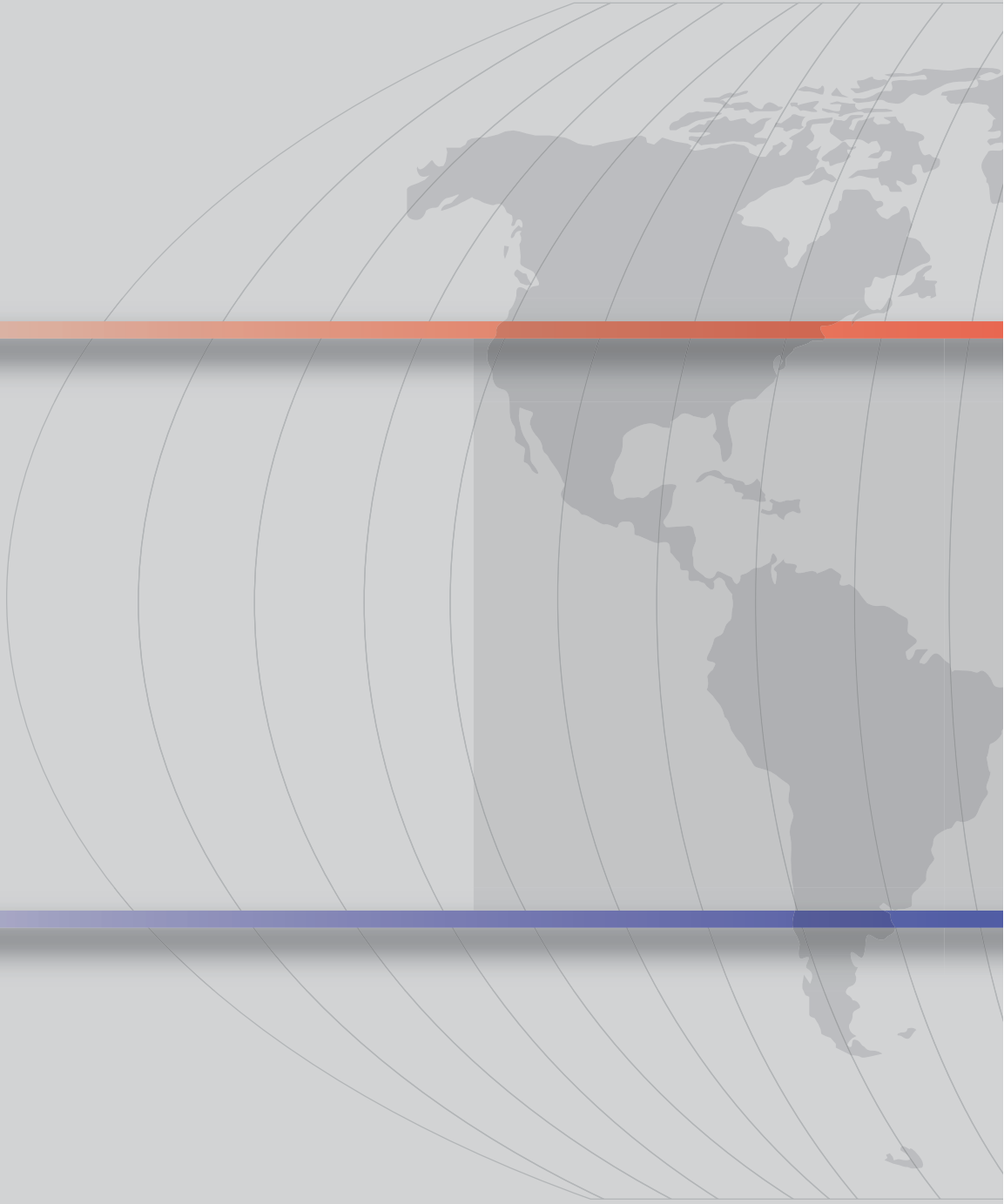

A member of the FRIMEC International Group