

AIR-COOLED SPLIT DUCTED (R410A SERIES) Large Condensing Unit

Models: FASN200-600

FASD200C-600C

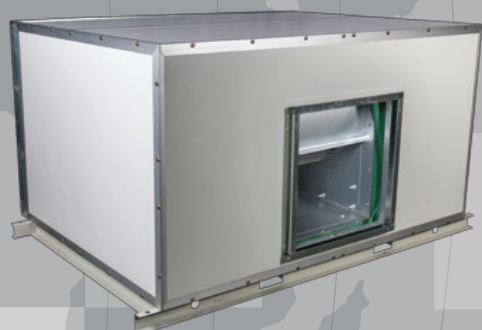

Contents

Product Nomenclature	2
Features.....	3
Engineering Specifications	4
General Data.....	4
Electrical Data.....	5
Operating Range.....	6
System Schematic Diagram.....	7
Controller Features and Algorithm	9
Fan Performance Curve	30
Dimensions.....	36
Wiring Diagrams.....	41
Installations.....	47
Servicing and Maintenance	55
Troubleshooting.....	56

Product Nomenclature

Air-Cooled Ducted Indoor Unit

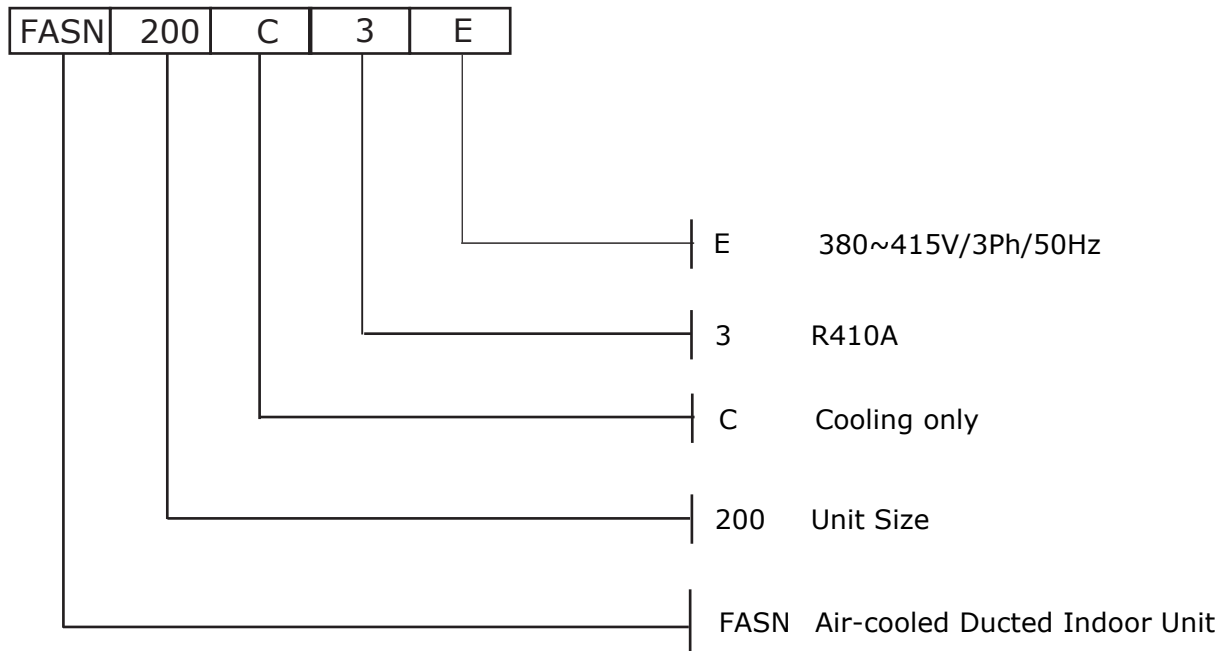

Air-Cooled Ducted Outdoor Unit

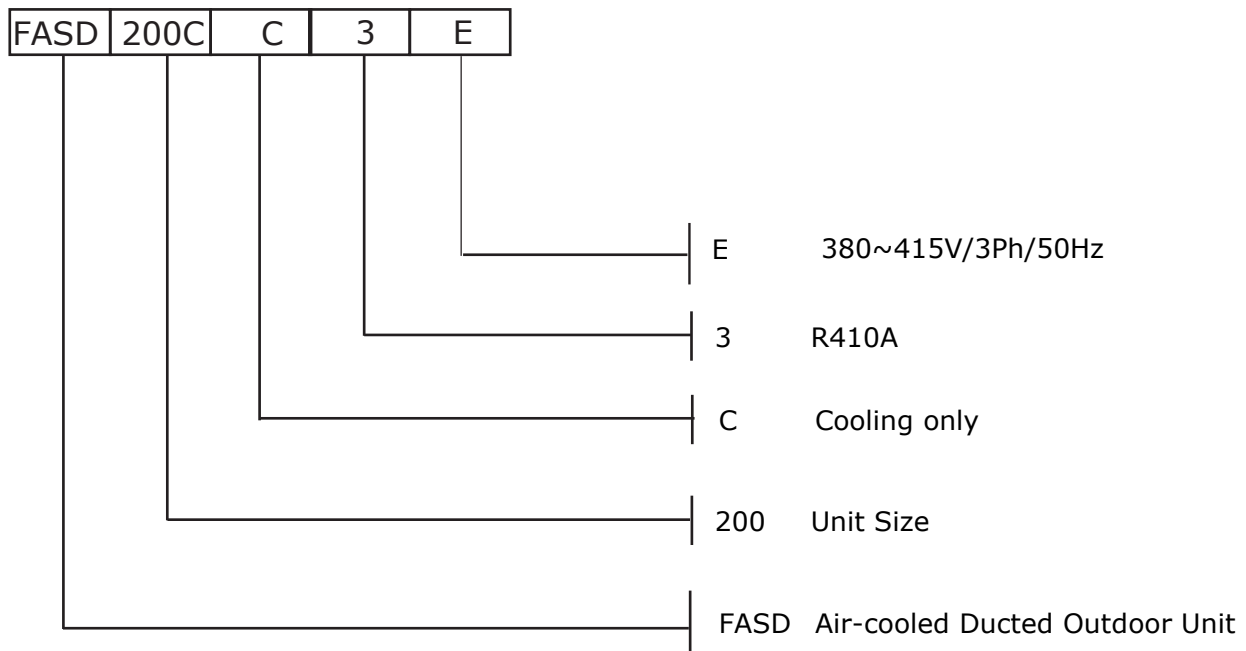

Features

Wide Range of Product

Comprises various models with wide cooling capacity to cater for various needs in residential, commercial and industrial application.

Multi Circuit Design

Part load capability offers continuous comfort, greater savings and provides highly flexible solutions for physical constraints at site. It also prolongs lifespan of compressors and reduces big electrical surges.

Low Noise

The outdoor units are using scroll compressors that have been proven to have superior performance and quiet operation. Statically and dynamically balanced fan blowers mounted in acoustically and thermally insulated casings provide excellent and quiet operation. The indoor units for larger capacity and air flow requirement are built with double skin panels made of powder coated steel (outer) and galvanized steel (inner) injected with high pressure PU foam.

Intelligent Control (Optional)

All the features can be easily set and changed through microcomputer-controlled LCD or LED controller. It ensures comfortable cooling is delivered to the user with press of a button and hassle free.

Simple Installation

Compact and light weight design of the units enable easy installation and space saving.

Engineering Specifications

General Data - Air-cooled Split Ducted R410A (Large Condensing Unit)

Model		Indoor Unit	FASN	200	250	300	400	500	600
		Outdoor Unit	FASD	200C	250C	300C	400C	500C	600C
Rated Cooling Capacity			kW	58.6	73.3	87.9	117.2	146.5	175.8
			Btu/h	200,000	250,000	300,000	400,000	500,000	600,000
Indoor Unit	Type	Double Skin							
	Dimension	Width	mm	2,248	2,241	2,152	2,432	2,782	2,782
		Length	mm	1,297	1,347	1,547	1,547	1,637	1,737
		Height	mm	810	1,155	1,175	1,450	1,450	1,650
	Weight	kg	258	312	366	567	663	830	
	Fan	Air Volume	CMH	10,000	12,500	15,000	20,000	25,000	30,000
			CFM	5,886	7,358	8,829	11,772	14,715	17,658
		ESP	Pa	250	300	300	300	400	400
		Power Supply	V/Ph/Hz	380~415/3/50					
		Sound Pressure Level	dB(A)	66	66	67	68	68	70
	Condensate Water Pipe	mm (in)	25.4 (1")						
Outdoor Unit	Compressor Type	Scroll Compressor							
	Compressor Quantity	Set	2	2	2	4	4	4	
	Condenser Type	Crossed Finned Cu Tube with Hydrophilic Fin							
	Dimension	Width	mm	1,103	1,103	1,103	1,212	1,212	1,212
		Length	mm	1,154	1,154	1,154	2,366	2,366	2,366
		Height	mm	1,871	1,871	1,871	2,001	2,001	2,001
	Weight	kg	320	335	385	740	761	835	
	Power Supply	V/Ph/Hz	380~415/3/50						
	Total Input Power	kW	22.41	26.31	31.43	44.8	54.12	64.33	
	Rated Load Amp (RLA)	A	42.46	47.46	61.17	84.66	97.09	123.88	
	Maximum Running Amp (MRA)	A	51.10	57.70	68.90	104.60	118.00	126.60	
Refrigerant	Refrigerant Charge	kg	7.25 x 2	7.65 x 2	9.20 x 2	7.25 x 4	7.65 x 4	9.20 x 4	
	Type	R410A							
	Precharge Gas	Nitrogen Holding Charge							
	Pipe Connection Type	Brazed							
Connecting Pipe Dimension	Liquid Pipe	mm (in)	12.7 x2 (1/2"x2)	12.7 x2 (1/2"x2)	15.88x2 (5/8"x2)	12.7x4 (1/2"x4)	12.7x4 (1/2"x4)	15.88x4 (5/8"x4)	
	Suction Pipe	mm (in)	25.40x2 (1"x2)	28.58x2 (1 1/8"x2)	34.92x2 (1 3/8"x2)	25.40x4 (1"x4)	28.58x4 (1 1/8"x4)	34.92x4 (1 3/8"x4)	

Note:

1. Products are tested in accordance to AHRI 340/360.
2. Cooling capacity is based on 26.7 °C DB / 19.4 °C WB for indoor air, 35.0 °C DB / 23.9 °C WB for ambient temperature.
3. Equivalent length of pipe used in performance test is 10m.
4. External static pressure data shown is for standard unit.
5. Products are not pre-charged with refrigerant upon leaving factory.
6. The noise level is measured in test-room condition. The actual noise level at site will differ due to environmental noise or other reasons.
7. Special design Desuperheater heat recovery option: please contact factory
8. The manufacturer reserves the rights to change the specifications without prior notice.

Electrical Data - Air Cooled Split Ducted R410A (Large Condensing Unit)

VOLT	ITEM		FASN/FASD200C	FASN/FASD250C	FASN/FASD300C
415V	TOTAL POWER INPUT	kW	22.41	26.31	31.43
	RATED LOAD AMP	A	42.46	47.46	61.17
	POWER FACTOR	%	73	77	71
	COMPRESSOR POWER INPUT	kW	17.60	20.90	25.60
	RATED LOAD AMP	A	33.60	37.60	50.60
	OUTDOOR FAN POWER INPUT	kW	2.05	2.12	2.13
	RATED LOAD AMP	A	4.18	4.28	4.29
	INDOOR FAN POWER INPUT	kW	2.76	3.29	3.70
	RATED LOAD AMP	A	4.68	5.58	6.28
	INDOOR FAN POWER OUTPUT	kW	3.00	4.00	5.50
	MOTOR POLE		4	4	4

VOLT	ITEM		FASN/FASD400C	FASN/FASD500C	FASN/FASD600C
415V	TOTAL POWER INPUT	kW	44.80	54.12	64.33
	RATED LOAD AMP	A	84.66	97.09	123.88
	POWER FACTOR	%	74	78	72
	COMPRESSOR POWER INPUT	kW	35.20	41.80	51.52
	RATED LOAD AMP	A	67.20	75.20	101.20
	OUTDOOR FAN POWER INPUT	kW	4.16	4.36	4.38
	RATED LOAD AMP	A	8.46	8.70	8.72
	INDOOR FAN POWER INPUT	kW	5.44	7.96	8.43
	RATED LOAD AMP	A	9.00	13.19	13.96
	INDOOR FAN POWER OUTPUT	kW	7.50	11.00	11.00
	MOTOR POLE		4	4	4

Operating Range

Cooling

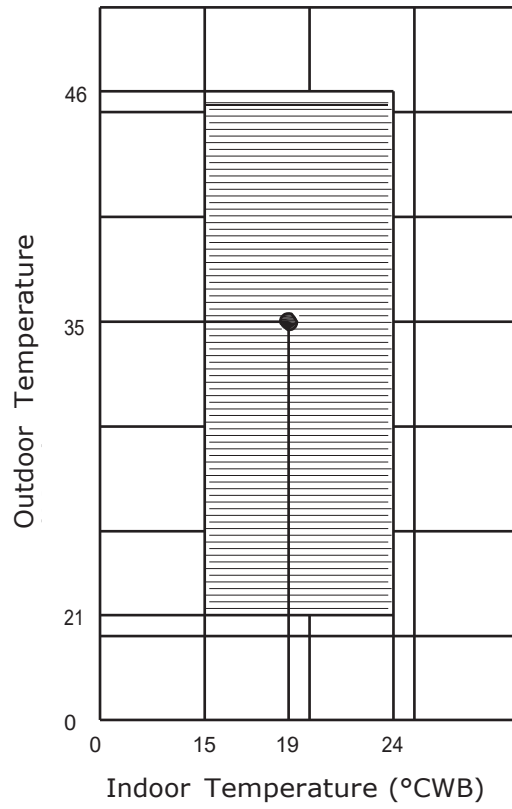

System Schematic Diagram

Model: FASN200/FASD200C

FASN250/FASD250C

FASN300/FASD300C

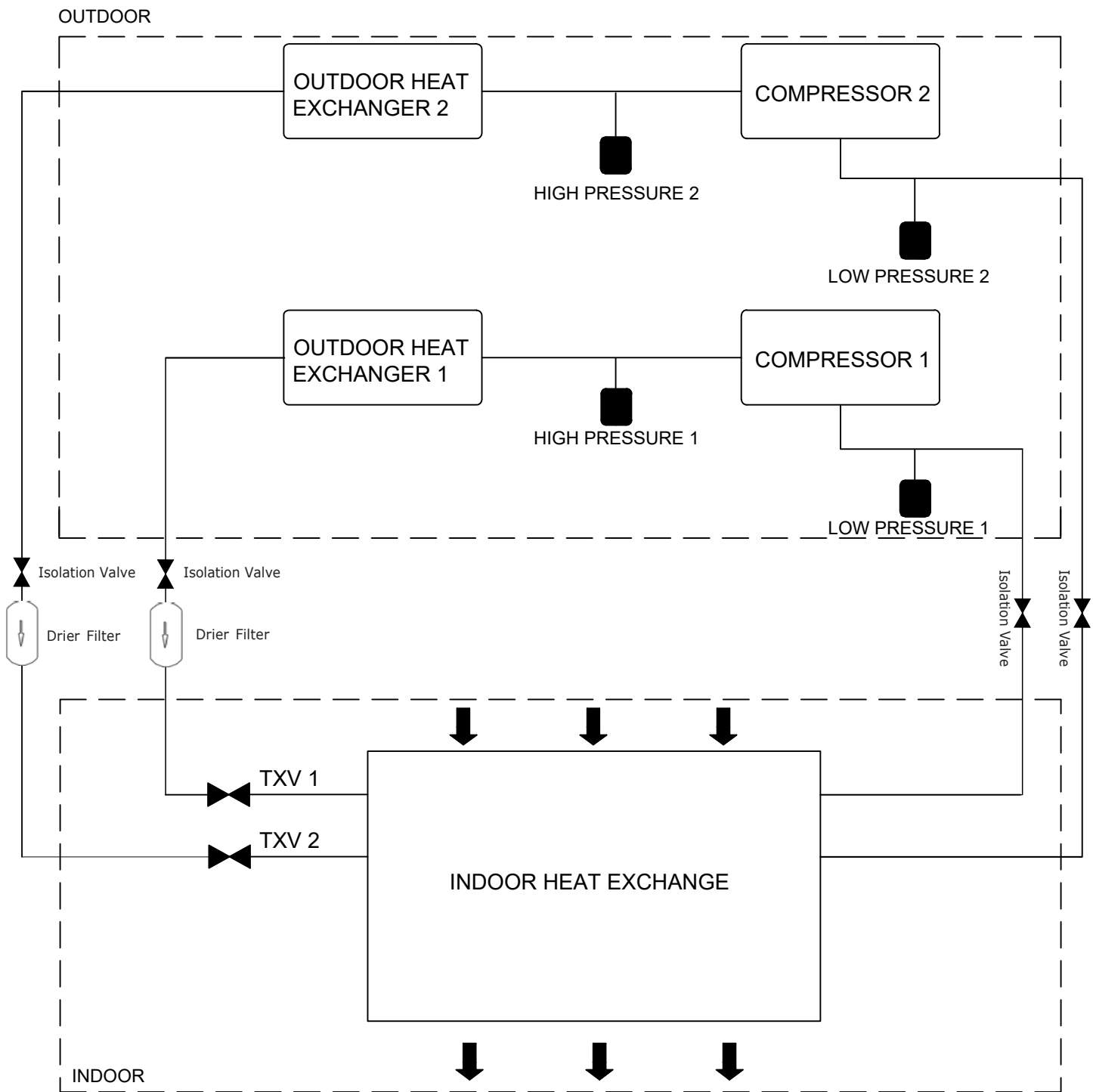

Note: Contractor is suggested to install Isolation Valve(s) and Drier Filter(s)

System Schematic Diagram

Model: FASN400/FASD400C
 FASN500/FASD500C
 FASN600/FASD600C

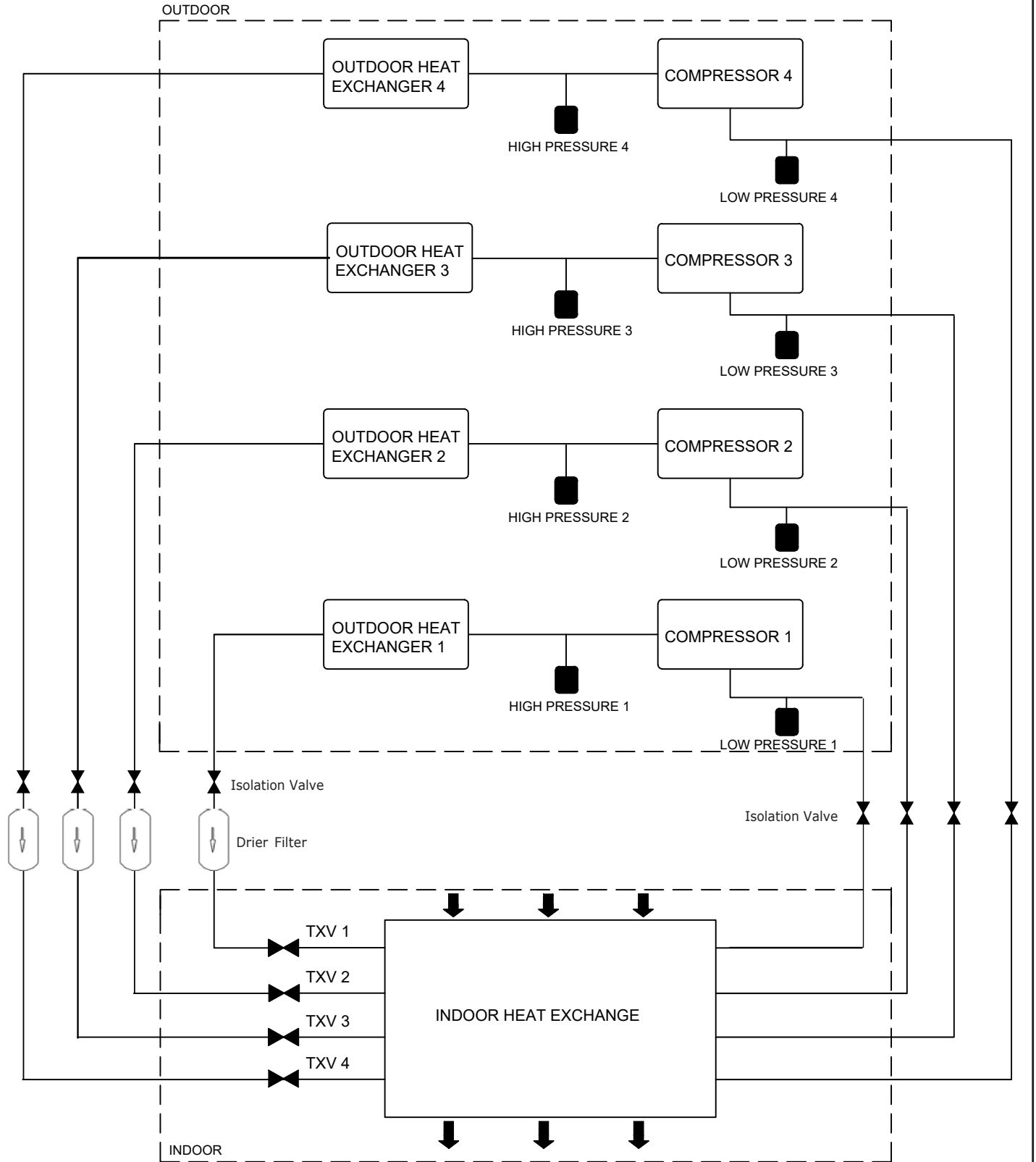



Note: Contractor is suggested to install Isolation Valve(s) and Drier Filter(s)

Controller Features and Algorithm

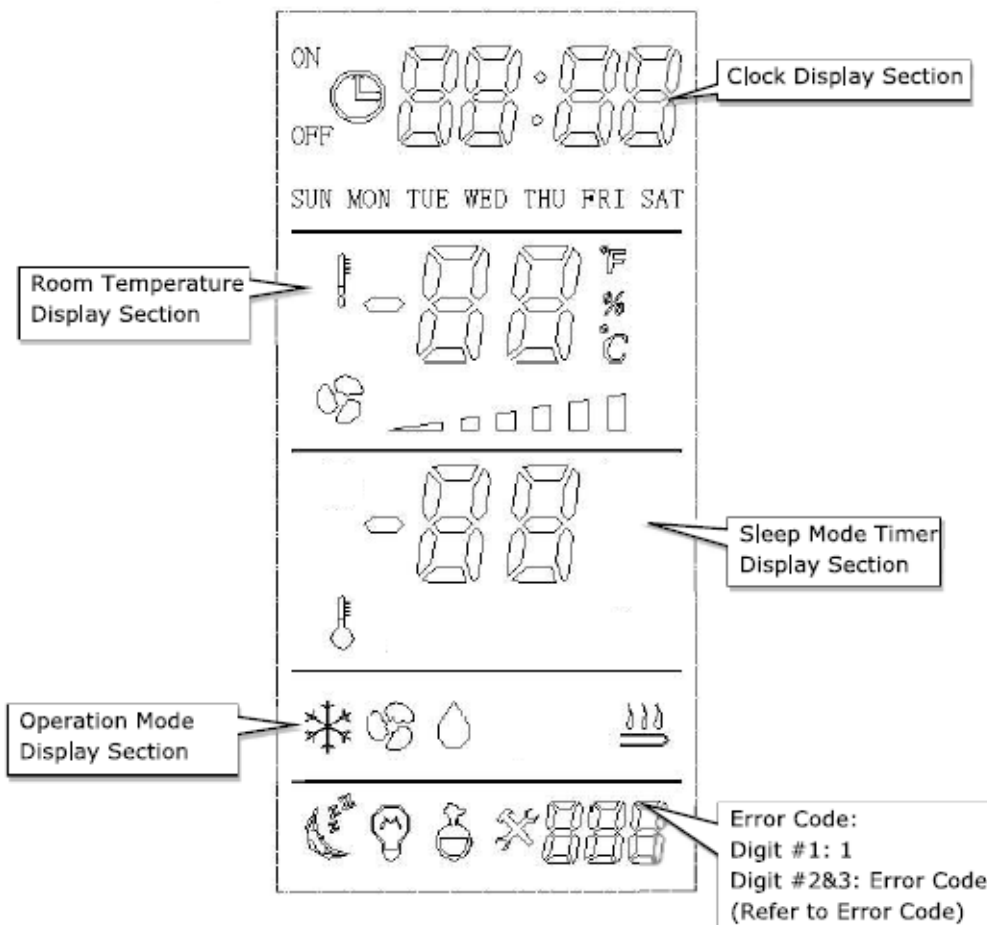
Operation instruction for FASN200/250/300



1. On/Off

- 1.1 Press (() button; unit will start function
- 1.2 Press again (() button; unit will stop function



2. Mode

- 2.1 Press ((M)) button to change the mode of operation
- 2.2 Toggle through Cool -Fan -Dry-Hot Water (Not Applicable)

3. Blower Speed

- 3.1 Press (() button to change the blower speed
- 3.2 Toggle through Auto -Low -Medium -High

4. Sleep Mode

- 4.1 Press (() button once to enable or disable sleep mode function ( symbol blink). Sleep mode function will be disabled when editing mode of operation, temperature and On/Off unit
- 4.2 Sleep mode timer display section shows «s)) C8hrs)
- 4.3 Press ((+)) button to increase 1 hour (Max 12 hours)
- 4.4 Press ((-)) button to decrease 1 hour (Min 1 hour)
- 4.5 Press ((v)) button to save the setting and exit
- 4.6 Press ((X)) button to exit

5. Energy Saving

- 5.1 Press (() button to enable or disable energy saving function
- 5.2 Energy saving function will be disabled automatically when editing mode of operation, temperature and On/Off unit

6. Set Temperature

- 6.1 Press((+)) or((-)) button to adjust the temperature (16C to 30C. default 24C), temperature display section will flash the temp setting

7. Key Lock

- 7.1 Press ((+)) and ((M)) button for 1sec to activate this function with symbol (() light up. Follow the same sequence to exit key lock. In key lock mode, user is allowed to access to on/off key only

8. Real Time Clock

8.1 Press  button for 3sec to enter this submenu

i. Press ((M)>) button to change the day of week:

SUN-MON-TUE-WED-THU-FRI-SAT

↑ _____ |

ii. Press ((+)) or «-» button to change the clock:

00:00-00:01.....-23:58-- 23:59



↑ _____ |

iii. Press ((y)>) button for 1sec to save the setting

iv. Press ((X)) button for 3sec to exit without saves the setting

9. On/Off Timer



9.1 If On/Off Timer being programmed,  will light up

9.2 Press  button for 6sec to into this submenu with  symbol flashing

i. Press ((M)>) button to select the day of week:

SUN-MON-TUE-WED-THU-FRI-SAT

↑ _____ |

ii. Press  or  button to select the clock:

00:00-00:01.....-23:58-- 23:59

↑ _____ |



iii. Press  button for 1sec to switch On timer or Off timer, clock display section will shows On/OF

iv. Press ((y)) button for 1sec to save the setting and exit

v. Press ((X))button for 3sec to cancel the current setting, clock display section will shows « --- }

vi. Press ((X)) button for 6sec to delete all setting, all day of week will light up, clock display section will show ((-----»

10. Compressor Status Display

10.1 Press  and  buttons for 3sec to into the submenu with ((CP)) shows in room temp. display section

- 10.2 Press «▲») or «▼») button to shows compressor no.1 or 2 statuses in clock display section
- 10.3 1(2):0n(0F) means compressor 1(2) is ON (OFF)
- 10.4 Press «(X)» button for 3sec to exit.

11. Parameters Check

- 11.1 Press «») and «(M)» buttons for 3sec to browse the following temperature:

No	Parameter (C°)
1	Return air temperature
2	N/A
3	N/A
4	Indoor coil temperature no.1
5	Indoor coil temperature no.2
6	N/A

- 11.2 Press «▲») or «▼») button to select temperature
- 11.3 Press «(X)» button for 3sec to exit

12. Error/Protect Code Display

- 12.1 Symbol ((X)) will light up and display error code when there is any system failure
- 12.2 When multiple errors occur, all error codes will be displayed one after another
- 12.3 Press ((X)) button to clear the error
- 12.4 Error Code:

No.	Error Code	Fault
1	01	Filter dirty
2	02	Sys.1 indoor coil temp. sensor failure
3	03	Phase failure
4	04	Sys.1 insufficient refrigerant
5	05	N/A
6	06	N/A
7	07	N/A
8	08	N/A
9	09	Sys.1 low pressure protection
10	10	Sys.2 low pressure protection
11	11	N/A
12	12	Filter dirty
13	13	Sys.1 high pressure protection
14	14	Sys.2 high pressure protection
15	15	N/A
16	16	N/A
17	17	Sys.2 indoor coil temp. sensor failure
18	18	Sys.2 insufficient refrigerant
19	19	N/A
20	20	N/A
21	21	N/A
22	22	N/A
23	23	N/A
24	24	Return air temperature sensor error
25	25	N/A
26	26	N/A
27	27	N/A
28	28	N/A
29	29	N/A

Modbus Protocol

Networking (Building Automation System)

Topology

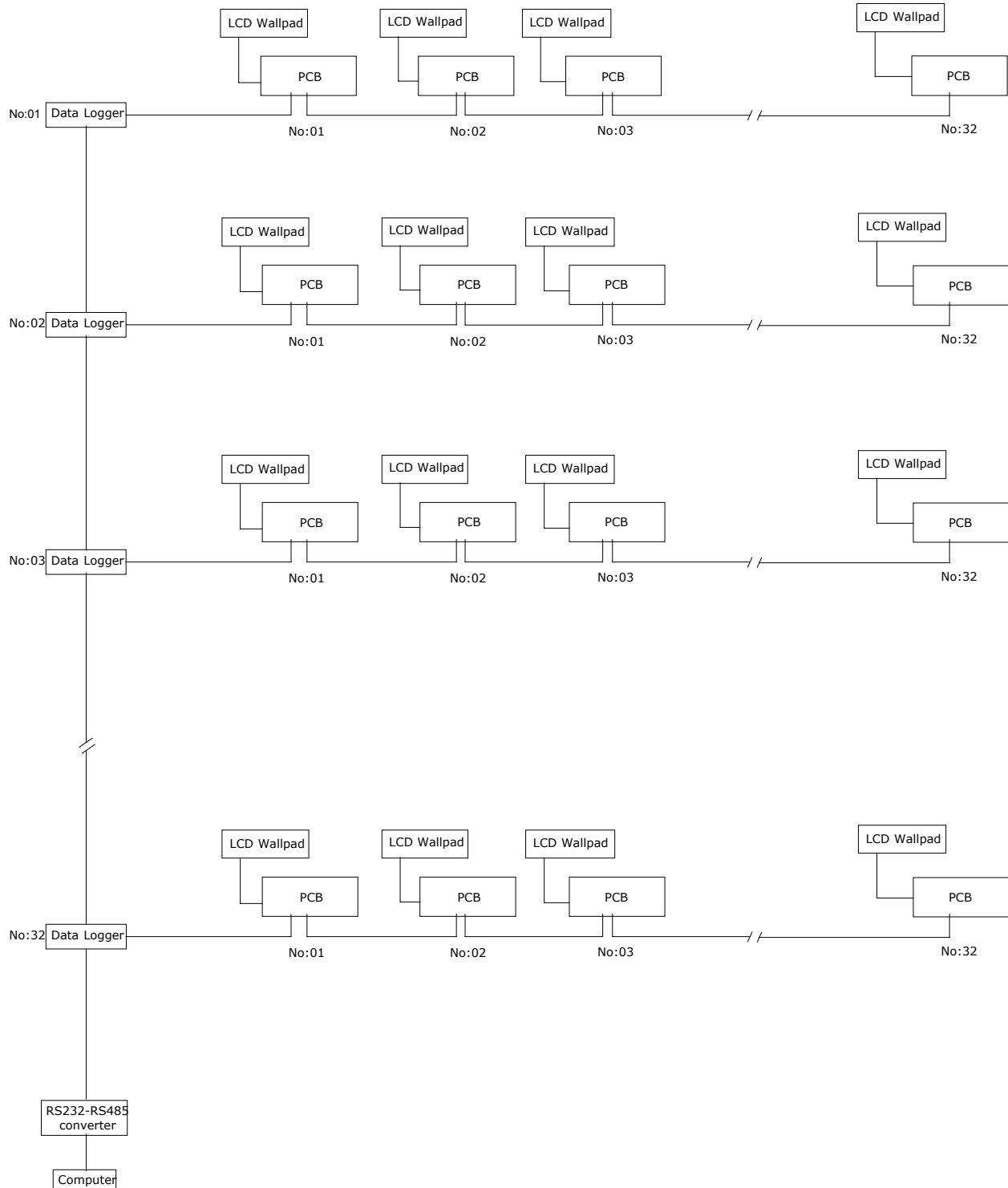

General Modbus Protocol

System Setup		
Connection port	: RS-485	
Communication way	: Half duplex	
Communication format	: Asynchronous Serial Communication : 1 start bit, 8 data bits, 1 stop bit	
Baud rate	: 9600bps	
Communication method	: Master-slave (PC or master controller as Master, others as Slave)	
BUS standard	: MODBUS protocol, RTU (Remote Terminal Unit) mode	
Rate	: Query rate – minimum 200ms, Timeout rate – minimum 200ms	
Function Code	Description	Definition
01 (0x01)	Read Coils	This function code is used to read from 1 to 2000 contiguous status of coils in a remote device.
02 (0x02)	Read Discrete Inputs	This function code is used to read from 1 to 2000 contiguous status of discrete inputs in a remote device.
03 (0x03)	Read Holding Registers	This function code is used to read the contents of a contiguous block of holding registers in a remote device.
04 (0x04)	Read Input Registers	This function code is used to read from 1 to approx. 125 contiguous input registers in a remote device.
05 (0x05)	Write Single Coil	This function code is used to write a single output to either ON or OFF in a remote device.
06 (0x06)	Write Single Register	This function code is used to write a single holding register in a remote device
15 (0x0F)	Write Multiple Coils	This function code is used to force each coil in a sequence of coils to either ON or OFF in a remote device.
16 (0x10)	Write Multiple registers	This function code is used to write a block of contiguous registers (1 to approx. 120 registers) in a remote device.

Control Point List

COIL(bit) Read 01 (0x01) Write 05 (0x05) Write 15 (0x0F)	Address	Description	
	1	On/Off unit	Applicable to both water-cooled and air-cooled system
	2	Reserved	
	3	Reserved	
	4	Reserved	
	5	Reserved	
	6	Reserved	
	7	Reserved	
	8	Reserved	

DISCRETE STATUS(bit) Read 02 (0x02)	Address	Water-cooled DX	Air-cooled DX	Description
	4000	High speed	High speed	Read discrete inputs 0 – Not in operation 1 – In operation
	4001	Medium speed	Medium speed	
	4002	Low speed	Low speed	
	4003	Reserved	Reserved	
	4004	Water pump	Outdoor fan	
	4005	Electric heater	Electric heater	
	4006	Compressor	Compressor	
	4007	Four-way valve	Four-way valve	
4008				

DISCRETE STATUS(bit) Read 02 (0x02)	Address	Water-cooled DX	Air-cooled DX	Description
	1	Reserved	Reserved	Read discrete inputs 0 – No error 1 – Error
	2	Reserved	Defrost	
	3	Reserved	Reserved	
	4	Refrigerant leak	Refrigerant leak	
	5	Return air temp sensor error	Return air temp sensor error	
	6	Indoor coil temp sensor error	Indoor coil temp sensor error	
	7	Entering water temp sensor error	Outdoor coil temp sensor error	
	8	Compressor overload	Compressor overload	
	9	Condensing water error	Reserved	
	10	Low pressure error	Low pressure error	
	11	High pressure error	High pressure error	
	12	Reserved	Outdoor air temp sensor error	
	13	Reserved	Reserved	
	14	Reserved	Reserved	
	15	Reserved	Reserved	
	16	Reserved	Reserved	
	17	Flow switch error	Reserved	
	18	Condensing water temp difference error	Reserved	

Controller Features and Algorithm

Operation instruction for FASN400/500/600

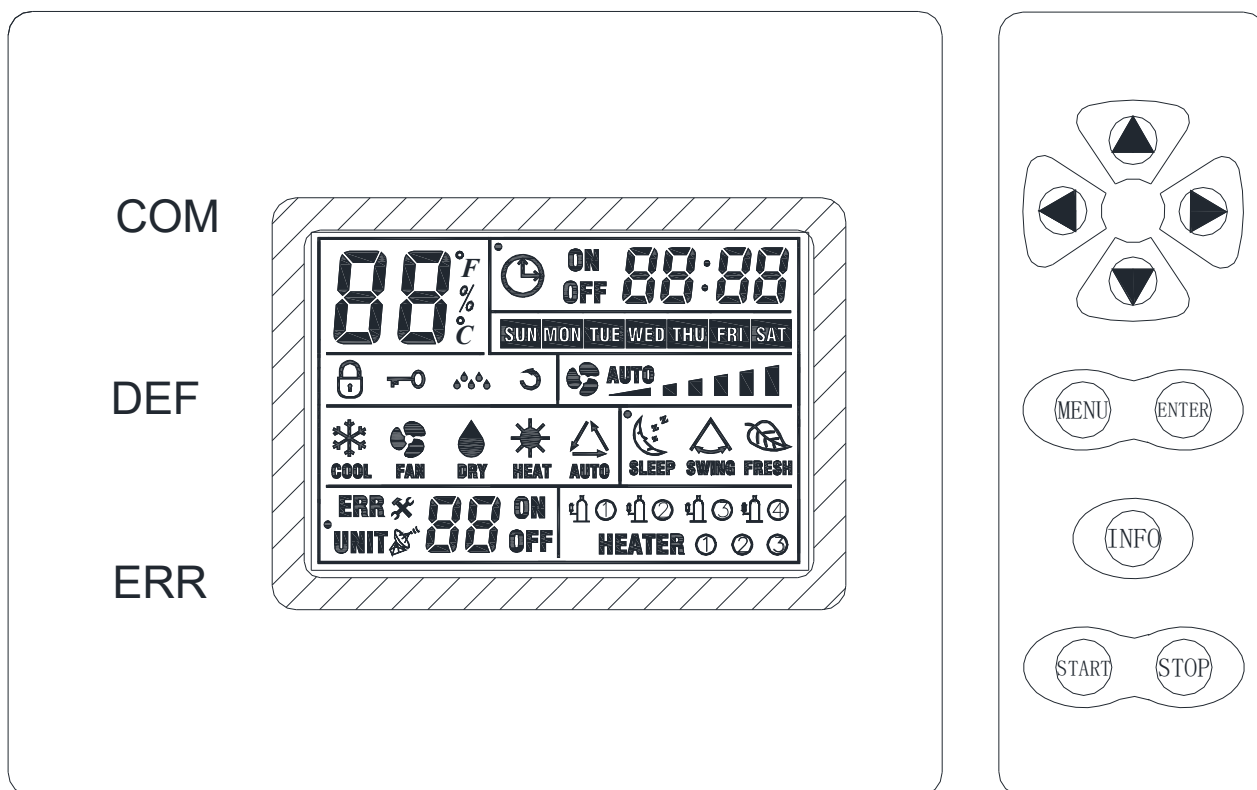

The multi colour backlighting LCD wallpad accept the command from the membrane switch to control the following:-

- Mode: Cool→Fan→Heat
- Independent cool mode and heat mode set temperature
- Room temperature display
- Real time clock [RTC] display
- Programmable on/off timer
- Compressor operation status display
- Heater operation status display
- Indoor fan operation status display
- Remote on/off display
- Alarm status and its error code display
- Buzzer beeping upon key press acknowledgement
- Battery to maintain the RTC operation upon power failure
- Key lock function
- Control parameter settings

Control Parameter Setting

Press MENU key on the main screen will activate the system to enter into the desired submenu according to the sequence of Set Temp[not available for fan mode] → Mode setting → RTC setting → On timer setting → Off timer setting → Set Temp[not available for fan mode]. Upon completion of parameter settings, press ENTER key to exit. Details of operation are as follow:

1) Set temp

Press MENU key once in cool or heat mode to enter into this submenu. Temperature display section will flash the temp setting of the current mode. Press ▲ or ▼ key to adjust the set temperature. Upon completion of editing, press ENTER key to exit.

2) Mode



Press MENU key twice to enter into this submenu. Mode display section will flash the current mode setting. Press ▲ or ▼ key to change the mode setting. Upon completion of editing, press ENTER key to exit.

3) RTC

Press MENU key three times to enter into this submenu with  symbol flashing. Press ▲ or ▼ key once will increase or decrease the RTC setting in 1 minute increment. Hold ▲ or ▼ key for 3 sec will change the RTC setting in 1 hour increment. Press ◀ or ▶ key to change day of week setting. Upon completion of editing, press ENTER key to exit.



4) On timer

Press MENU key four times to enter into this submenu with  ON symbol flashing. If on timer for the current day is empty, timer display area shows ◁ ° ▷ ▷ ▷. Press ▲ or ▼ key once will activate the timer. Once the timer is activated, press ▲ or ▼ key once will increase or decrease the timer setting in 1 minute increment. Hold ▲ or ▼ key for 3 sec will change the timer setting in 1 hour increment. Press ◀ or ▶ key to change day of week the timer to be programmed. Press INFO key to cancel the timer setting. Upon completion of editing, press ENTER key to exit.

Should there be on timer being programmed  symbol will light up. Should there be on timer available for the current day waiting for execution,  ON symbol will light up.

5) Off timer

Press MENU key five times to enter into this submenu with  OFF symbol flashing. If off timer for the current day is empty, timer display area shows ◁ ° ▷ ▷ ▷. Press ▲ or ▼ key once will activate the timer. Once the timer is activated, press ▲ or ▼ key once will increase or decrease the timer setting in 1 minute increment. Hold ▲ or ▼ key for 3 sec will change the timer setting in 1 hour increment. Press ◀ or ▶ key to change day of week the timer to be programmed. Press INFO key to cancel the timer setting. Upon completion of editing, press ENTER key to exit.

Should there be off timer being programmed  symbol will light up. Should there be off timer available for the current day waiting for execution,  OFF symbol will light up.

6) Key lock

Press MENU and ENTER keys on the main menu for 3 sec to activate this function with  symbol light up. Follow the same sequence to exit key lock. In key lock mode, user is allowed to access to On/Off key only.

7) Information

Press INFO key on the main menu for information browsing. Press ▲ or ▼ key to select the required information as follow:

Temp display section	Timer display section	Remarks
C0	Main board DIP switch setting	Display position 1-8 [correspond to bit7-bit0] in hexadecimal format.
C1	Room temperature	AD1 temp on main board
C2	Outdoor air temperature	AD2 temp on main board
C3	Supply air temperature	AD3 temp on main board
C4	Indoor coil 1 temp	AD4 temp on main board
C5	Indoor coil 2 temp	AD5 temp on main board
C6	Indoor coil 3 temp	AD6 temp on main board
C7	Indoor coil 4 temp	AD7 temp on main board

Press ENTER key to exit.

8) System control parameter

Press MENU and ▲ keys on the main menu for 3 sec to activate this function. Timer display section shows “0---“ asking for password entry. Press ▲ or ▼ key to change the value of the current digit being edit. Press ◀ or ▶ key to change the digit to be edited. Upon key in the correct password of 8699, press ENTER key to enter into the following menu:

Temp display section	Timer display section	Remarks
d0	Tcpoff, Anti-freeze protection	0~10°C, default 5°C
d1	Tdif, differential temp	3~15°C, default 5°C
d2	ODoff, head pressure protection	10~20°C, default 15°C
d3	Oddif, differential temperature	1~10°C, default 3°C
d4	Compressor consecutive startup interval	3~8min, default 5 min
d5	Thermostatical control cycle	1~10min, default 5 min
d6	Set temperature lower limit	10~20°C, default 16°C
D7	Set temperature upper limit	25~35°C, default 30°C

Press ◀ or ▶ key to select the item to be edited. Press ▲ or ▼ key to change the value of the item selected.

Press ▲ or ▼ key on the current menu for 3sec to get dEFU wording flashing on the timer section.

Press INFO key to reset the control parameter to default value.

Press INFO key to exit without saving the settings being changed.

Press ENTER key to exit and save the settings.

9) Error code display

Backlight color will turn to red when there is any system failure. ERR light will turn on and error display section will show the relevant error code as follow:

Error code	Remarks
1	Phase failure [manual reset]
2	Indoor fan failure [manual reset]
3	Condenser fan 1 overload [manual reset]
4	Condenser fan 2 overload [manual reset]
5	Condenser fan 3 overload [manual reset]
6	Condenser fan 4 overload [manual reset]
7	Comp 1 high pressure [manual reset]
8	Comp 1 low pressure [automatic then manual reset]
9	Comp 2 high pressure [manual reset]
10	Comp 2 low pressure [automatic then manual reset]
11	Comp 3 high pressure [manual reset]
12	Comp 3 low pressure [automatic then manual reset]
13	Comp 4 high pressure [manual reset]
14	Comp 4 low pressure [automatic then manual reset]
15	Heater failure [manual reset]
16	Room sensor failure [auto reset]
17	Outdoor air sensor failure [auto reset]
18	Supply air sensor failure [auto reset]
19	Indoor coil 1 sensor failure [auto reset]
20	Indoor coil 2 sensor failure [auto reset]
21	Indoor coil 3 sensor failure [auto reset]
22	Indoor coil 4 sensor failure [auto reset]
23	Reserved
24	Reserved
25	Indoor coil 1 anti-freeze[auto reset]
26	Indoor coil 2 anti-freeze[auto reset]
27	Indoor coil 3 anti-freeze[auto reset]
28	Indoor coil 4 anti-freeze[auto reset]

Manual reset: When there is failure occurred, press MENU and ▼ key for 3 sec to clear the errors.

10) Remote on/off

If the remote on/off input is opened, rOFF will be shown on the timer display section. Main board will go into standby mode even if the wallpad is at on status.

11) Communication indication

Communication LED will flash at regular speed if the communication between wallpad and main board is healthy.

12) Time shortening test mode

Within 1min upon power ON, press and hold MENU and ◀ for 3 seconds will enter time shortening test mode.

Networking (Building Automation System)

Topology

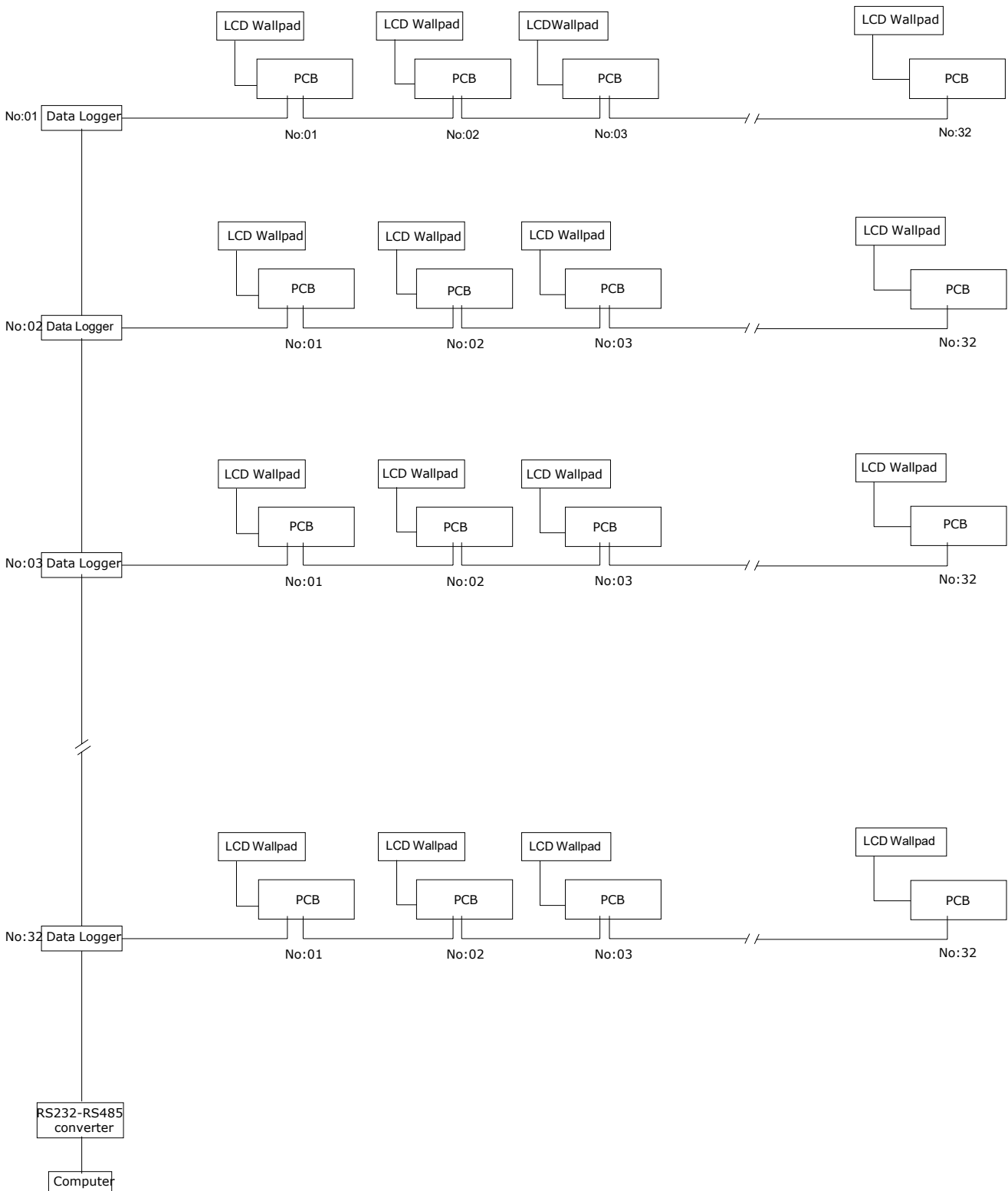

General Modbus Protocol

System Setup	
Connection port	: RS-485
Communication way	: Half duplex
Communication format	: Asynchronous Serial Communication
Baud rate	: 1 start bit, 8 data bits, 1 stop bit
Baud rate	: 9600bps
Communication method	: Master-slave (PC or master controller as Master, others as Slave)
BUS standard	: MODBUS protocol, RTU (Remote Terminal Unit) mode
Error checking	: CRC-16

Function Code	Description	Definition
01 (0x01)	Read Coils	This function code is used to read from 1 to 2000 contiguous status of coils in a remote device.
02 (0x02)	Read Discrete Inputs	This function code is used to read from 1 to 2000 contiguous status of discrete inputs in a remote device.
03 (0x03)	Read Holding Registers	This function code is used to read the contents of a contiguous block of holding registers in a remote device.
04 (0x04)	Read Input Registers	This function code is used to read from 1 to approx. 125 contiguous input registers in a remote device.
05 (0x05)	Write Single Coil	This function code is used to write a single output to either ON or OFF in a remote device.
06 (0x06)	Write Single Register	This function code is used to write a single holding register in a remote device
15 (0x0F)	Write Multiple Coils	This function code is used to force each coil in a sequence of coils to either ON or OFF in a remote device.
16 (0x10)	Write Multiple registers	This function code is used to write a block of contiguous registers (1 to approx. 120 registers) in a remote device.

Error Code	Description	Definition
02 (0x02)	Illegal Data Address	The data address (register number) received in the query is not an allowed address
04 (0x04)	Illegal Write Data	The data written in the query is not valid

Control Point List

COIL(bit) Read 01 (0x01) Write 05 (0x05) Write 15 (0x0F)	Address	Description	
	1	On/Off unit	Applicable to both water-cooled and air-cooled system
	2	Reserved	
	3	Reserved	
	4	Reserved	
	5	Reserved	
	6	Reserved	
	7	Reserved	
	8	Reserved	

DISCRETE STATUS(bit) Read 02 (0x02)	Address	Water-cooled package	Air-cooled package	Description
	4000	#1 compressor	#1 compressor	Read discrete inputs 0 – Not in operation 1 – In operation
	4001	#2 compressor	#2 compressor	
	4002	#3 compressor	#3 compressor	
	4003	#4 compressor	#4 compressor	
	4004	#1 electric heater	#1 electric heater	
	4005	#2 electric heater	#2 electric heater	
	4006	#3 electric heater	#3 electric heater	
	4007	Indoor blower	Medium speed	
	4008	Reserved	Reserved	
	4009	Water pump	Low speed	
	4010		High speed	
	4011		Reserved	
	4012		#1 outdoor fan	
	4013		#2 outdoor fan	
	4014		#3 outdoor fan	
4015		#4 outdoor fan		

DISCRETE STATUS(bit) Read 02 (0x02)	Address	Water-cooled package	Air-cooled package	Description
	1	Power failure	Power failure	
	2	Indoor blower error	Indoor blower error	
	3	Flow switch error	1# outdoor fan error	
	4	Water pump error	2# outdoor fan error	
	5	1# High pressure error	3# outdoor fan error	
	6	1# Low pressure error	4# outdoor fan error	
	7	2# High pressure error	1# High pressure error	
	8	2# Low pressure error	1# Low pressure error	
	9	3# High pressure error	2# High pressure error	
	10	3# Low pressure error	2# Low pressure error	
	11	4# High pressure error	3# High pressure error	
	12	4# Low pressure error	3# Low pressure error	
	13	1# Electric heater error	4# High pressure error	
	14	2# Electric heater error	4# Low pressure error	
	15	3# Electric heater error	Electric heater error	
	16	Return air temp sensor error	Return air temp sensor error	
	17	Entering water temp sensor error	Outdoor air temp sensor error	
	18	Leaving water temp sensor error	Supply air temp sensor error	
	19	1# Indoor coil temp sensor error	1# Indoor coil temp sensor error	Read discrete inputs 0 – No error 1 – Error
	20	2# Indoor coil temp sensor error	2# Indoor coil temp sensor error	
	21	3# Indoor coil temp sensor error	3# Indoor coil temp sensor error	
	22	4# Indoor coil temp sensor error	4# Indoor coil temp sensor error	
	23	Low water temperature protection	Reserved	
	24	Large water temp diff protection	Reserved	
	25	1# Indoor coil anti-freeze protection	1# Indoor coil anti-freeze protection	
	26	2# Indoor coil anti-freeze protection	2# Indoor coil anti-freeze protection	
	27	3# Indoor coil anti-freeze protection	3# Indoor coil anti-freeze protection	
	28	4# Indoor coil anti-freeze protection	4# Indoor coil anti-freeze protection	
	29		1# Refrigerant leak protection	
	30		2# Refrigerant leak protection	
	31		3# Refrigerant leak protection	
	32		4# Refrigerant leak protection	
	33		1# Outdoor coil temp sensor error	
	34		2# Outdoor coil temp sensor error	
	35		3# Outdoor coil temp sensor error	
	36		4# Outdoor coil temp sensor error	
	37		1# Indoor coil overheat protection	
	38		2# Indoor coil overheat protection	
	39		3# Indoor coil overheat protection	
40		4# Indoor coil overheat protection		

HOLDING REGISTER Read 03 (0x03) Write 06 (0x06) Write 16 (0x10)	Address	Descriptions			
	1	Set temperature (Air conditioning)			
	2	Reserved			
	3	Mode of operation:- 1 - Cooling 2 - Fan only 4 - Dehumidification 8 - Heating 16 - Auto			
	4	Indoor blower speed:- 1 - Low speed 2 - Medium speed 4 - High speed 8 - Auto			
	5	Reserved			
	6	Reserved			
	Address	Water-cooled package	Air-cooled package	Descriptions	
	2000	Return air temperature correction	Return air temperature correction	Temperature correction range (-5°C to 5°C)	
	2001	Entering water temp correction	Outdoor air temperature correction		
	2002	Leaving water temp correction	Supply air temperature correction		
	2003	1# Indoor coil temp correction	1# Indoor coil temp correction		
	2004	2# Indoor coil temp correction	2# Indoor coil temp correction		
	2005	3# Indoor coil temp correction	3# Indoor coil temp correction		
	2006	4# Indoor coil temp correction	4# Indoor coil temp correction	Lock features is applicable only when use with LCD wallpad type-T1	
	2007	System On/Off lock	1# Outdoor coil temp correction		
	2008	Mode of operation lock	2# Outdoor coil temp correction		
	2009	Set temperature lock	3# Outdoor coil temp correction		
	2010	Indoor blower speed lock	4# Outdoor coil temp correction		
	2011		System On/Off lock		
	2012		Mode of operation lock		
	2013		Set temperature lock		
	2014		Indoor blower speed lock		

Fan Performance Curve

FASN200

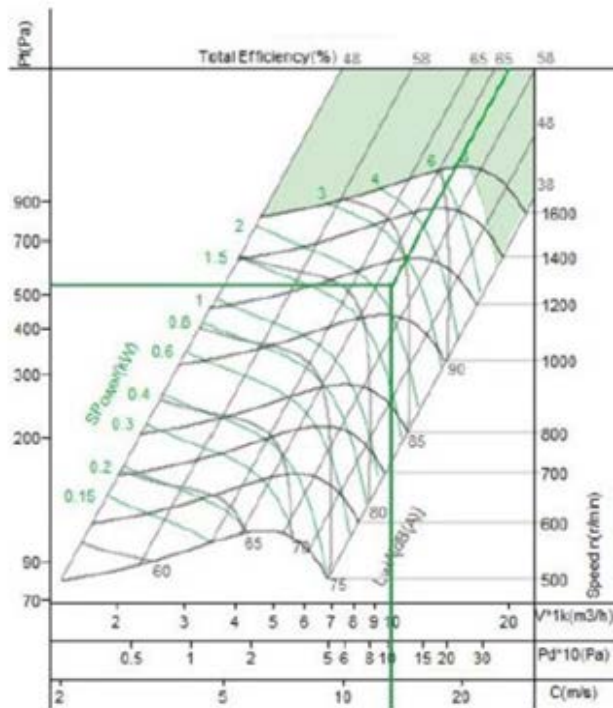

FASN250

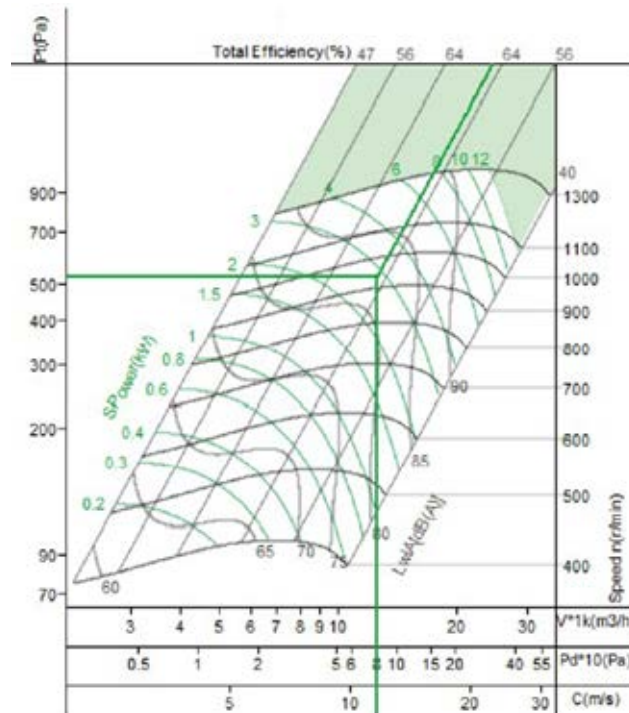

FASN300

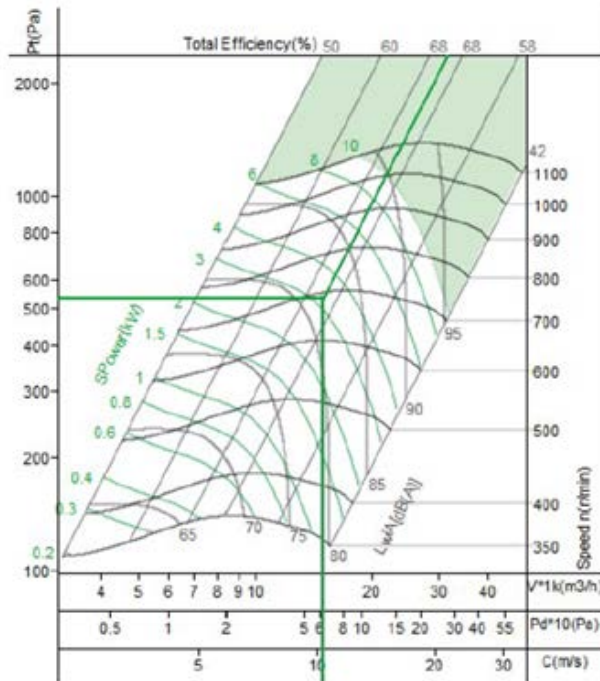

FASN400

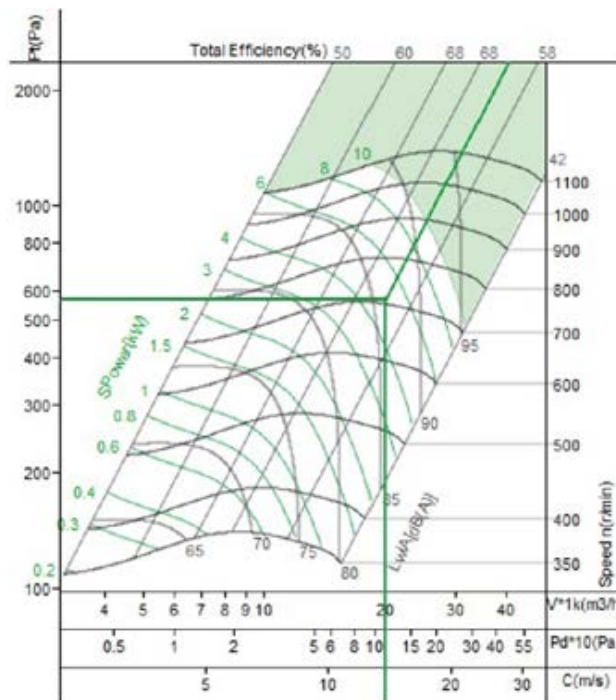

FASN500

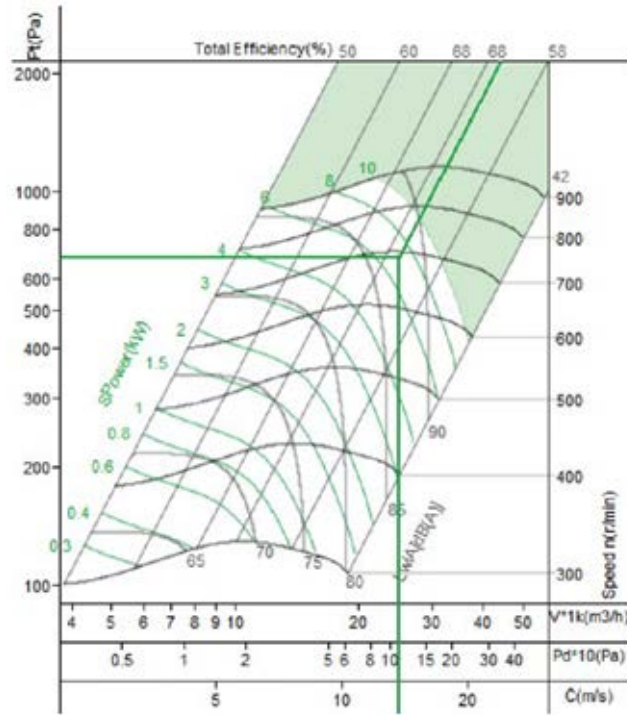

FASN600

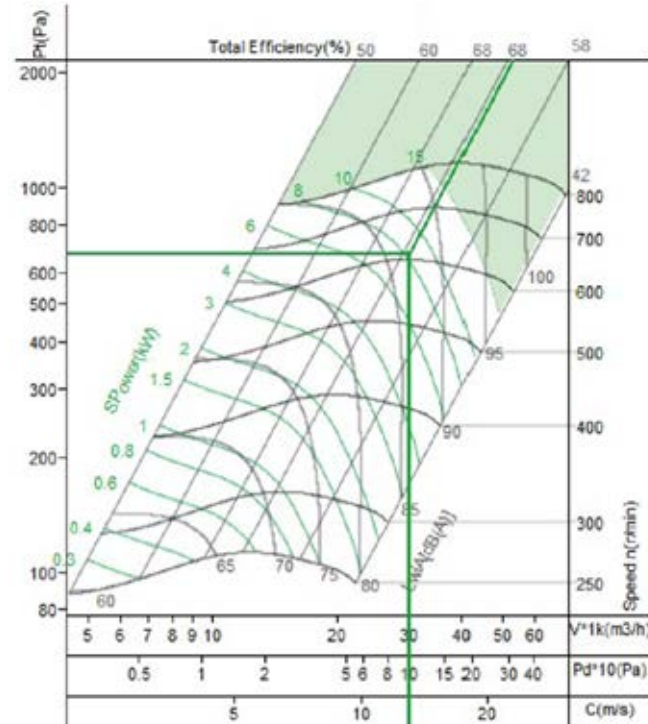

FASD 200C

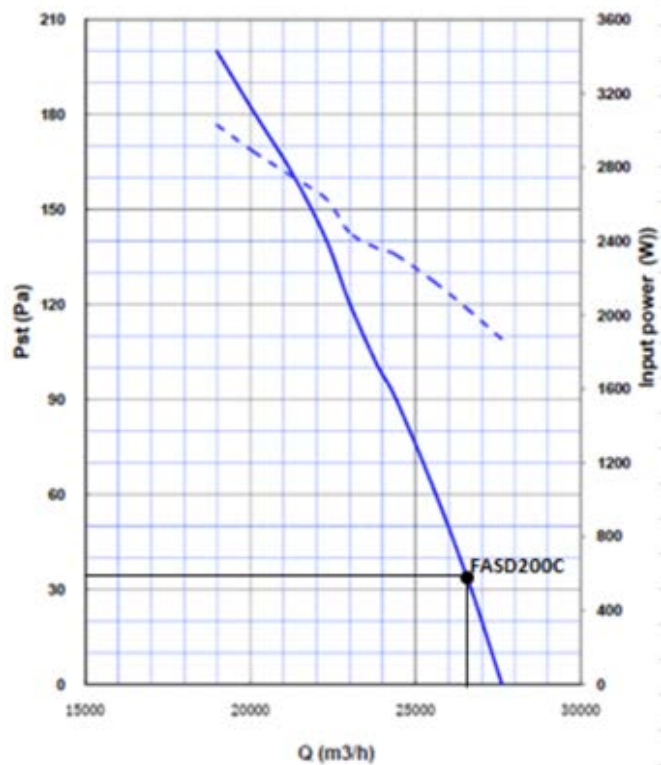

FASD 250C

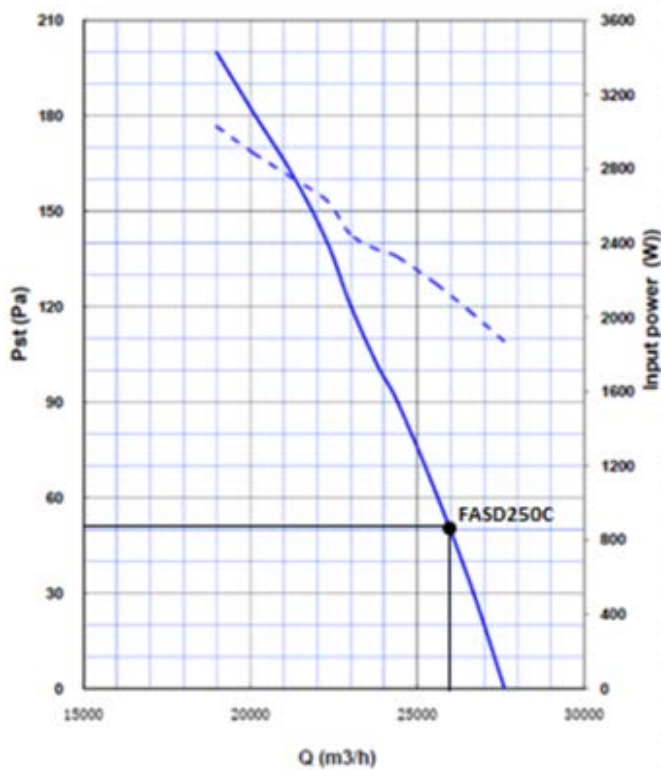

FASD 300C

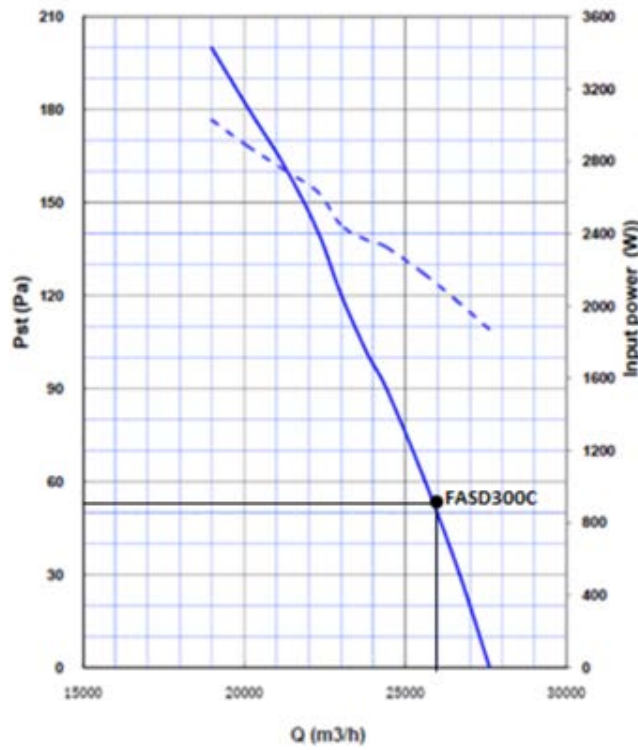

FASD 400C

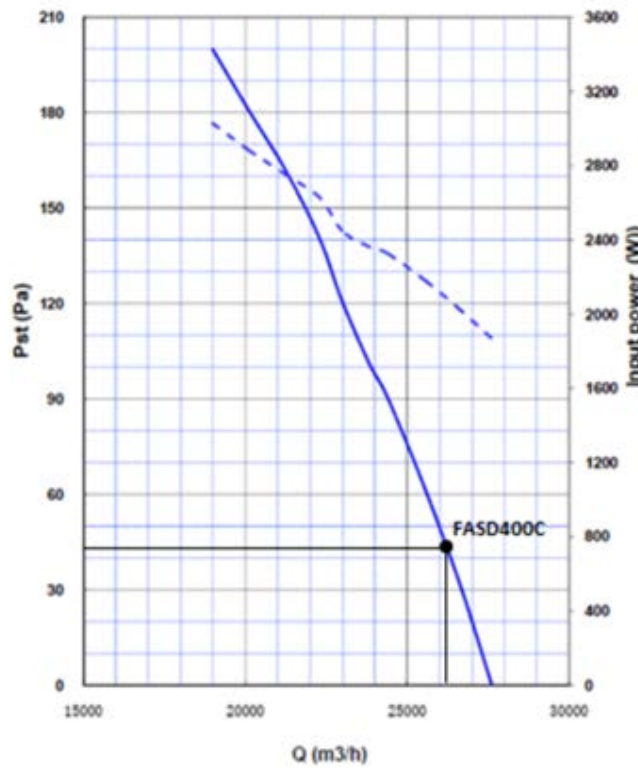

FASD 500C

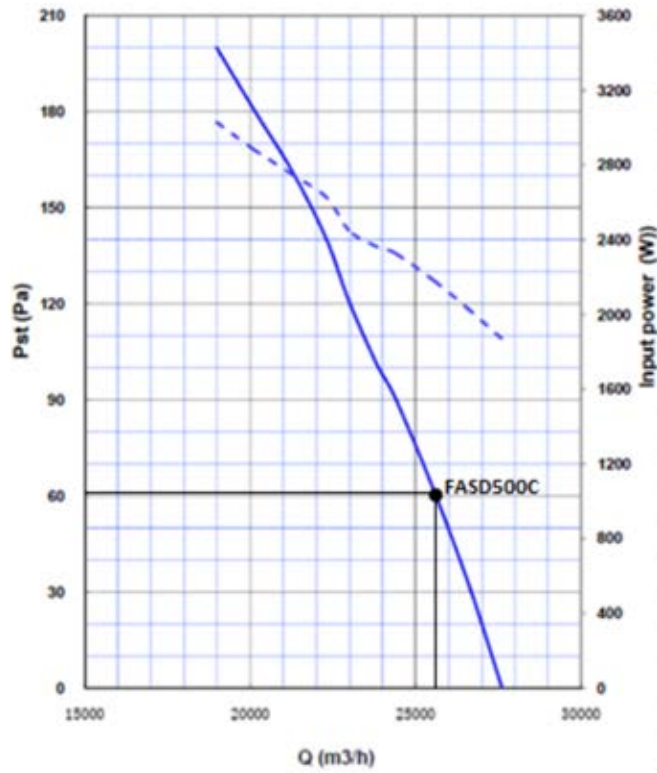

FASD 600C

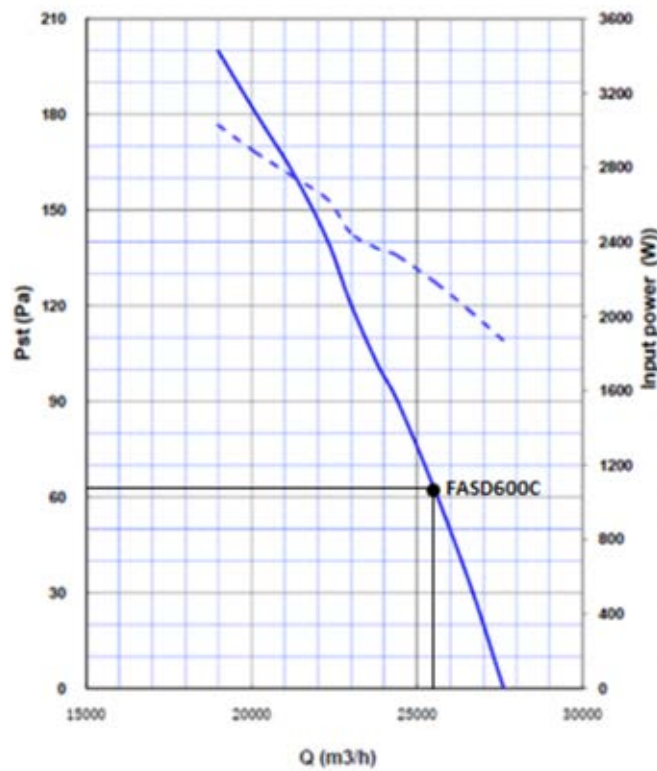

Dimensions

Model: FASN200

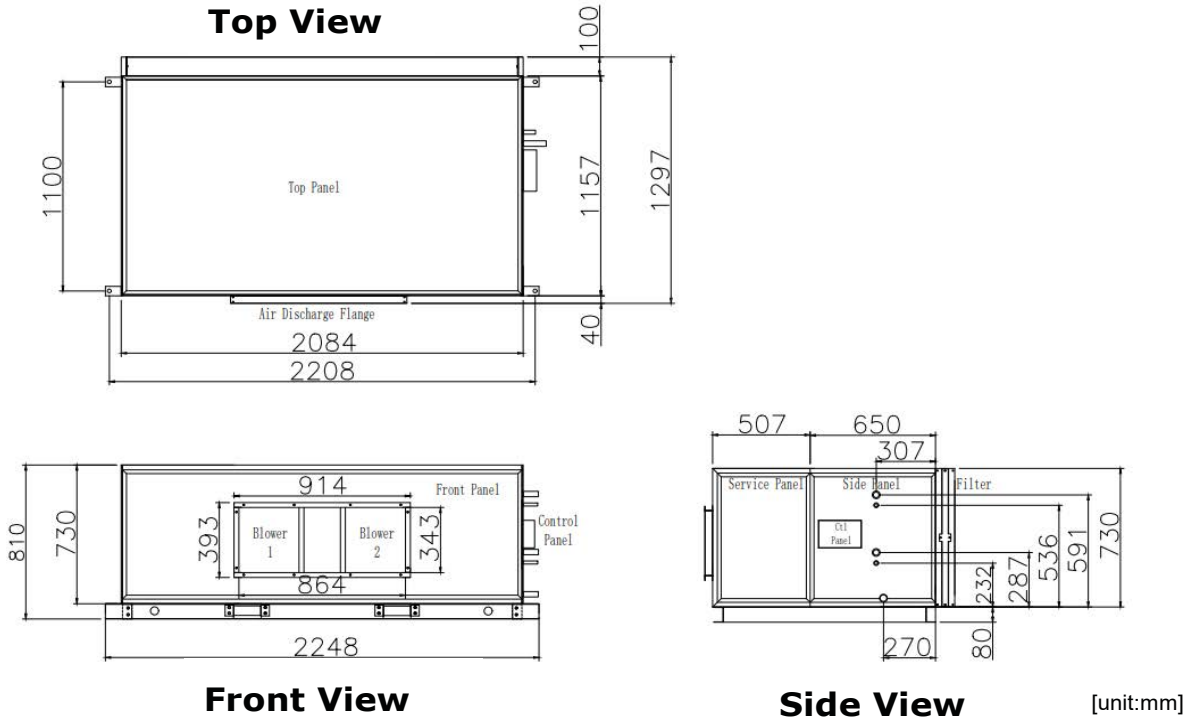

Model: FASN250

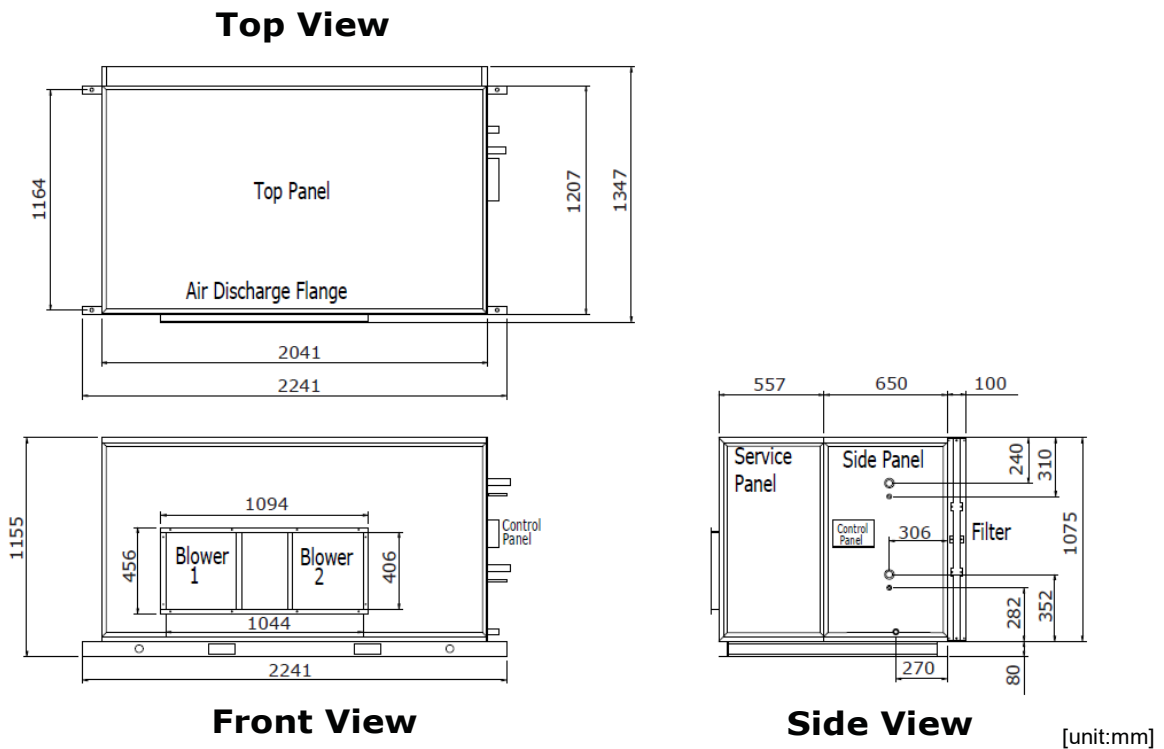

Model: FASN300

Top View

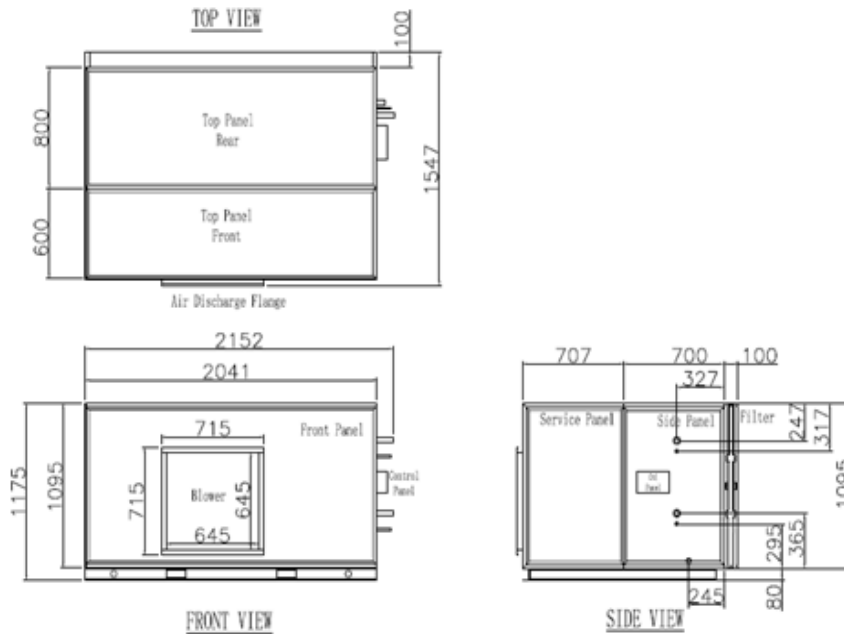

Front View

Side View

[unit:mm]

Model: FASN400/500/600

Top View

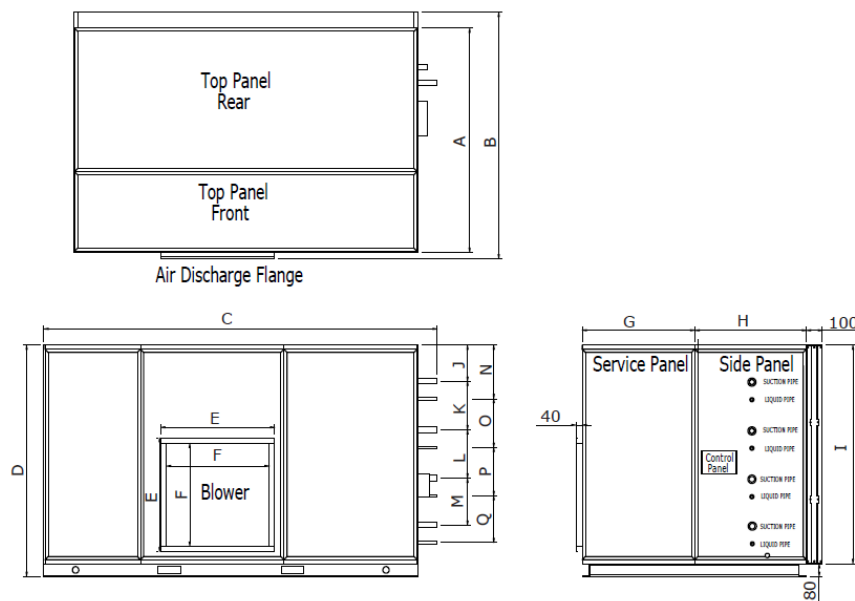

Front View

Side View

[unit:mm]

Model	Dimension(mm)																
	A	B	C	D	E	F	G	H	I	J	K	L	M	N	O	P	Q
FASN400	1407	1547	2432	1450	715	645	707	707	1370	188	305	305	293	298	305	305	293
FASN500	1497	1637	2782	1450	790	720	797	700	1370	188	305	305	293	298	305	305	293
FASN600	1597	1737	2782	1650	880	810	797	800	1570	224	330	356	381	334	330	356	381

Model: FASD200C/250C

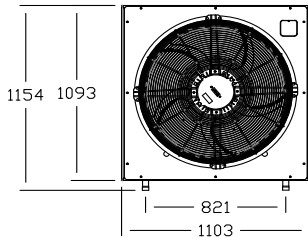

Top View

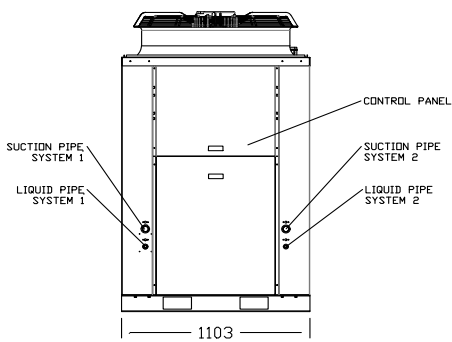

Front View

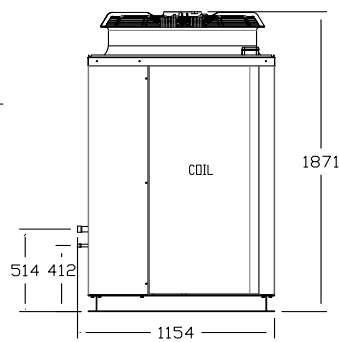

Side View

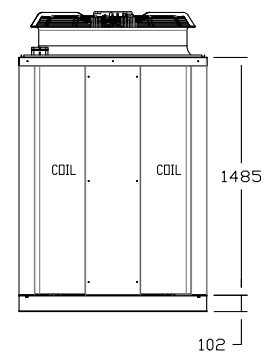

Back View

Unit : mm

Model: FASD300C

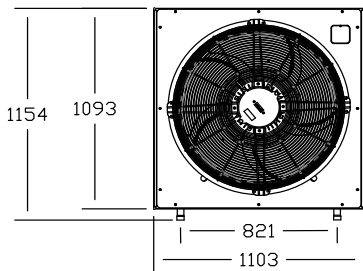

Top View

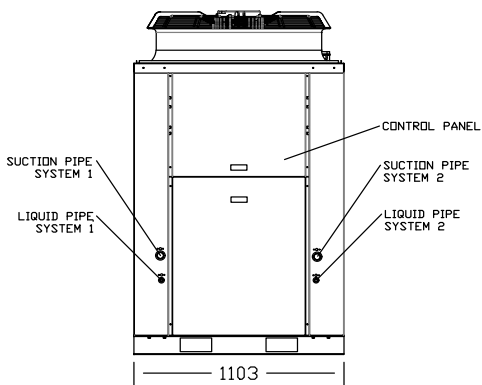

Front View

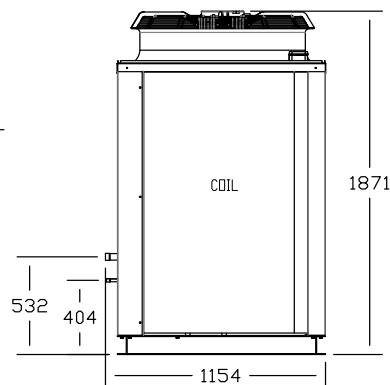

Side View

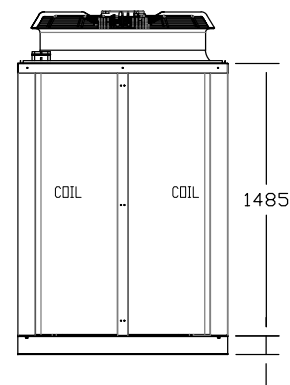

Back View

Unit : mm

Model: FASD400C/500C

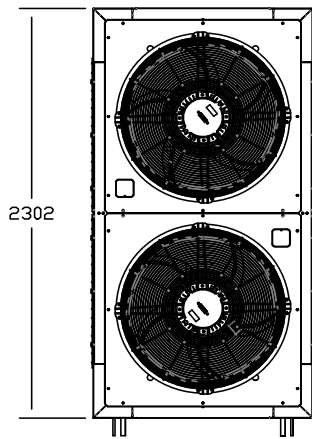

Top View

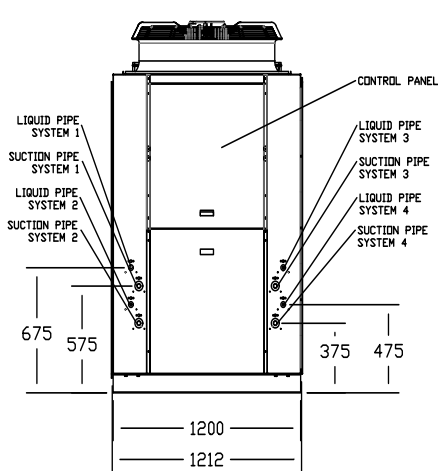

Front View

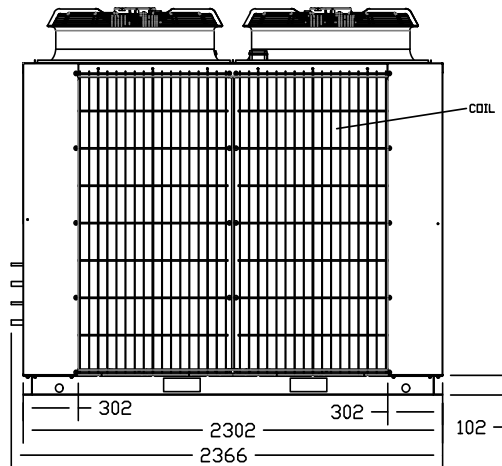

Side View

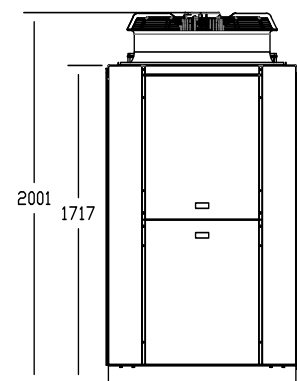

Back View

Unit : mm

Model: FASD600C

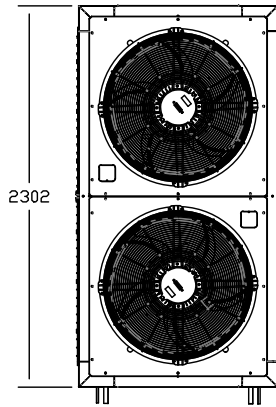

Top View

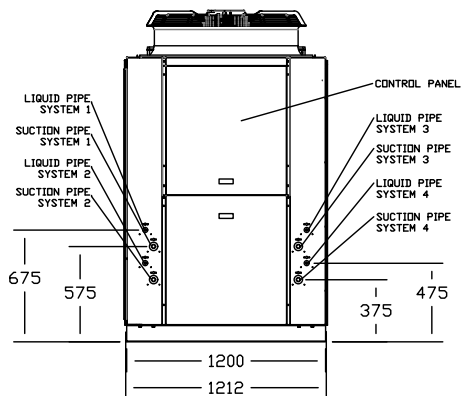

Front View

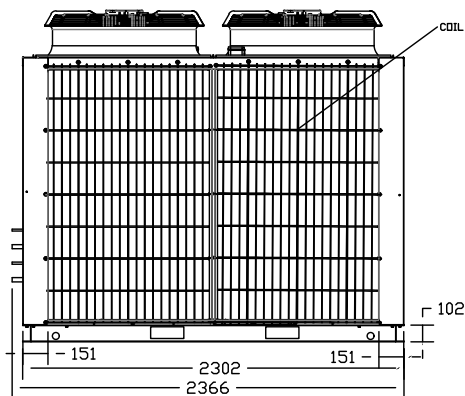

Side View

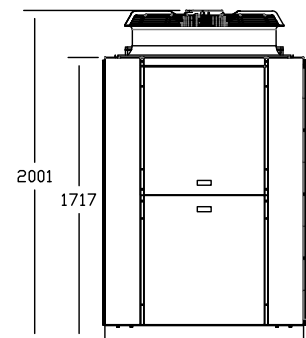

Back View

Unit : mm

Wiring Diagrams

Model: FASN200/FASD200C (With Control PCB)
FASN250/FASD250C (With Control PCB)
FASN300/FASD300C (With Control PCB)

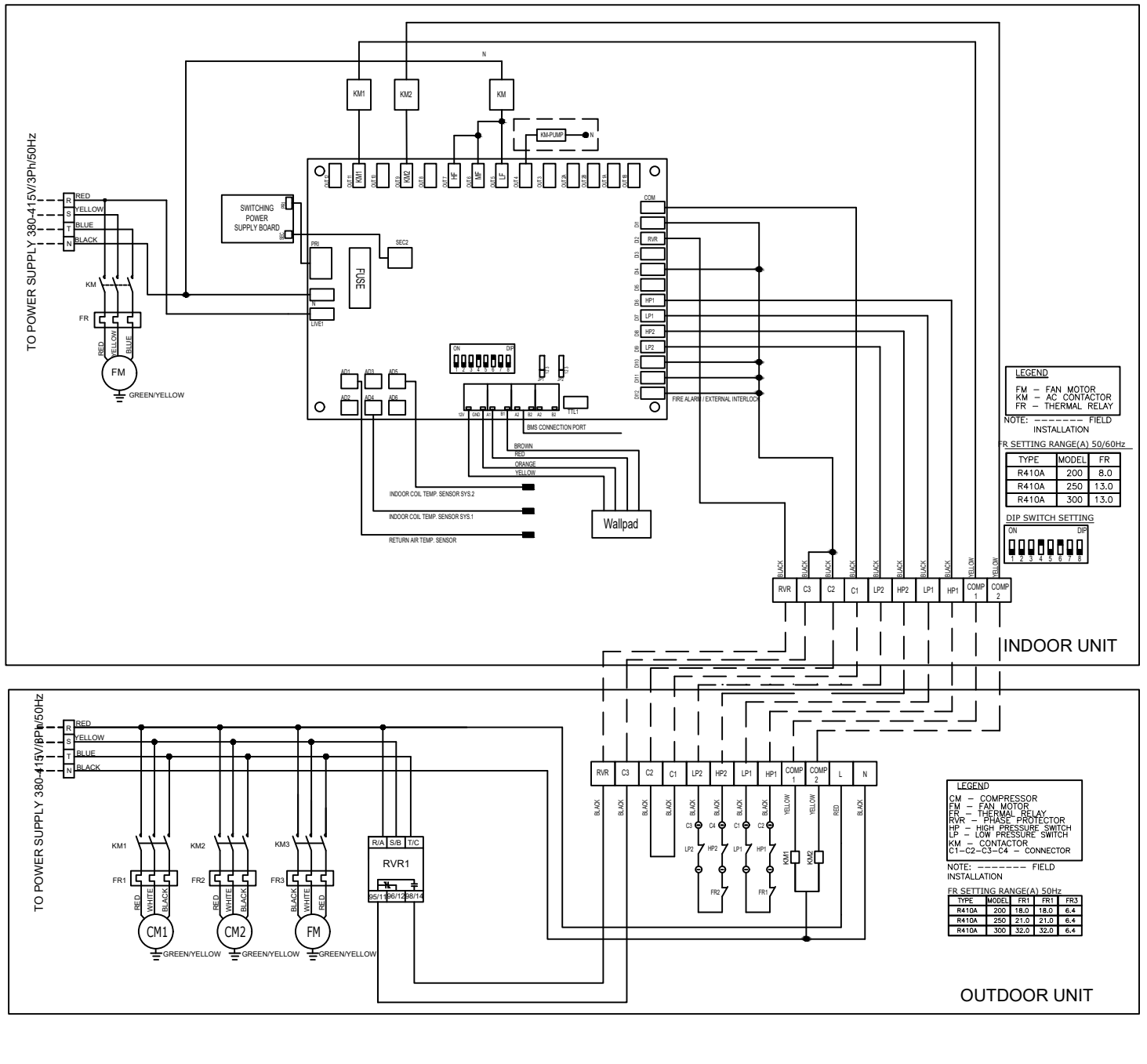

Model: FASN400/FASD400C (With Control PCB)

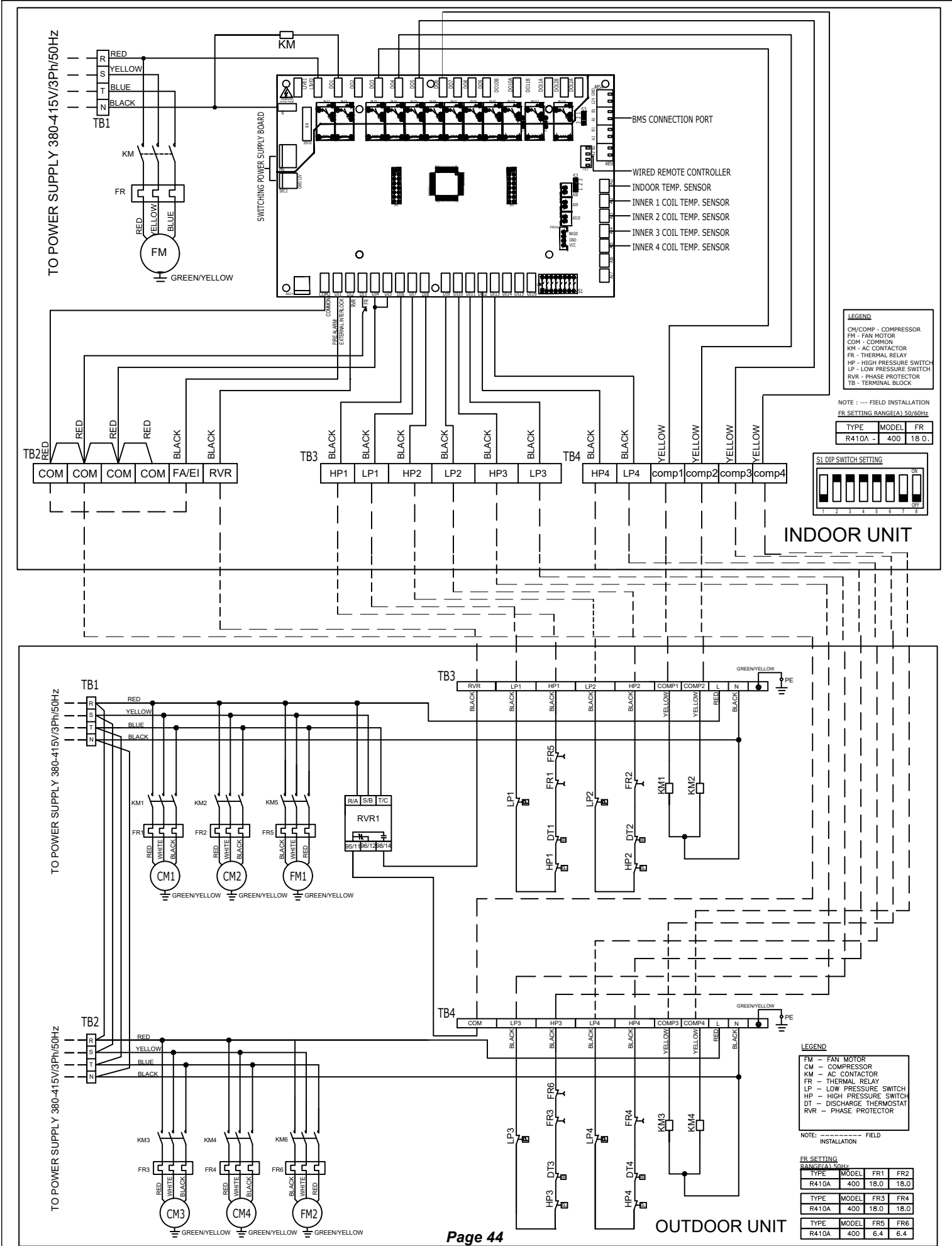

**Model: FASN500/FASD500C (With Control PCB)
FASN600/FASD600C (With Control PCB)**

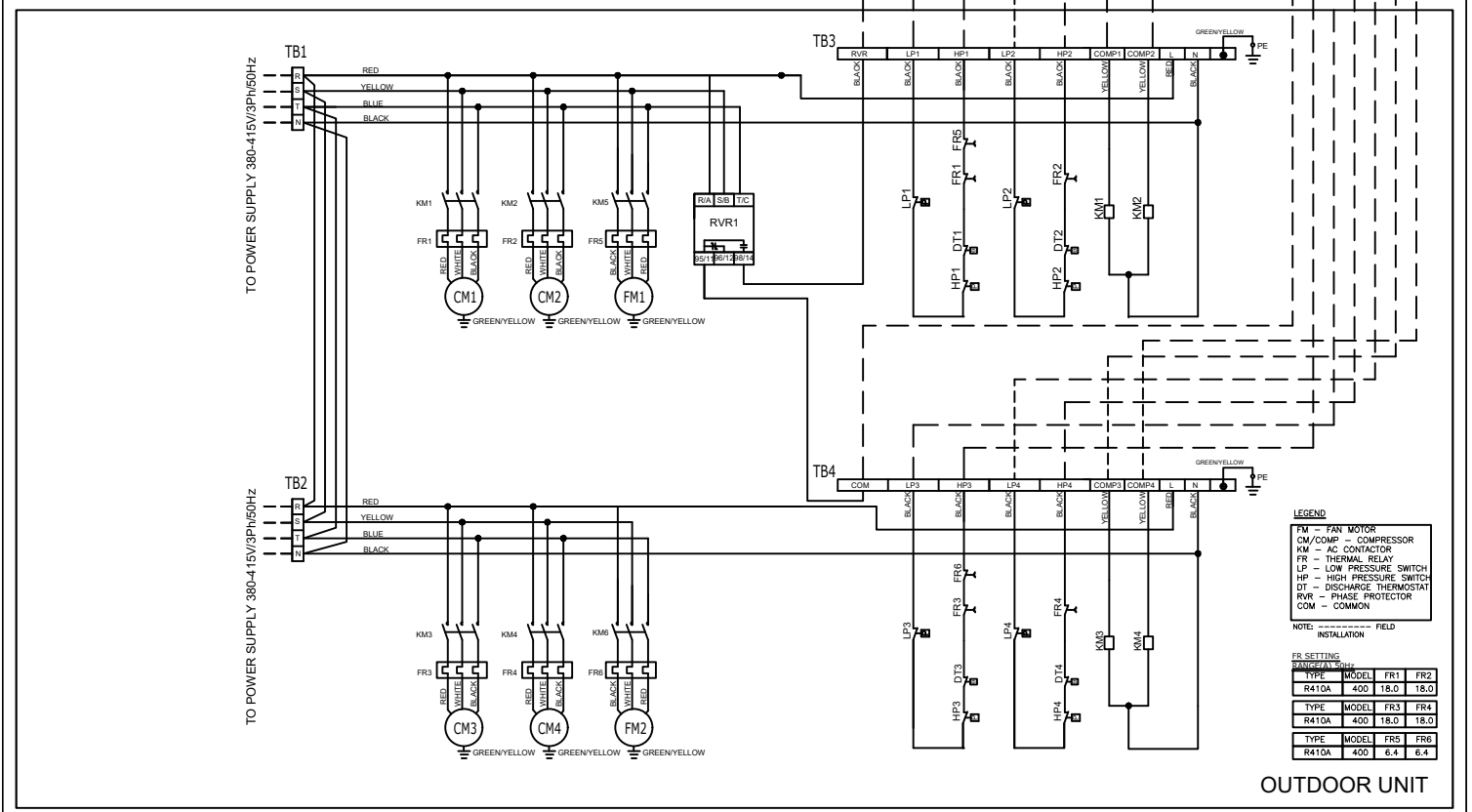
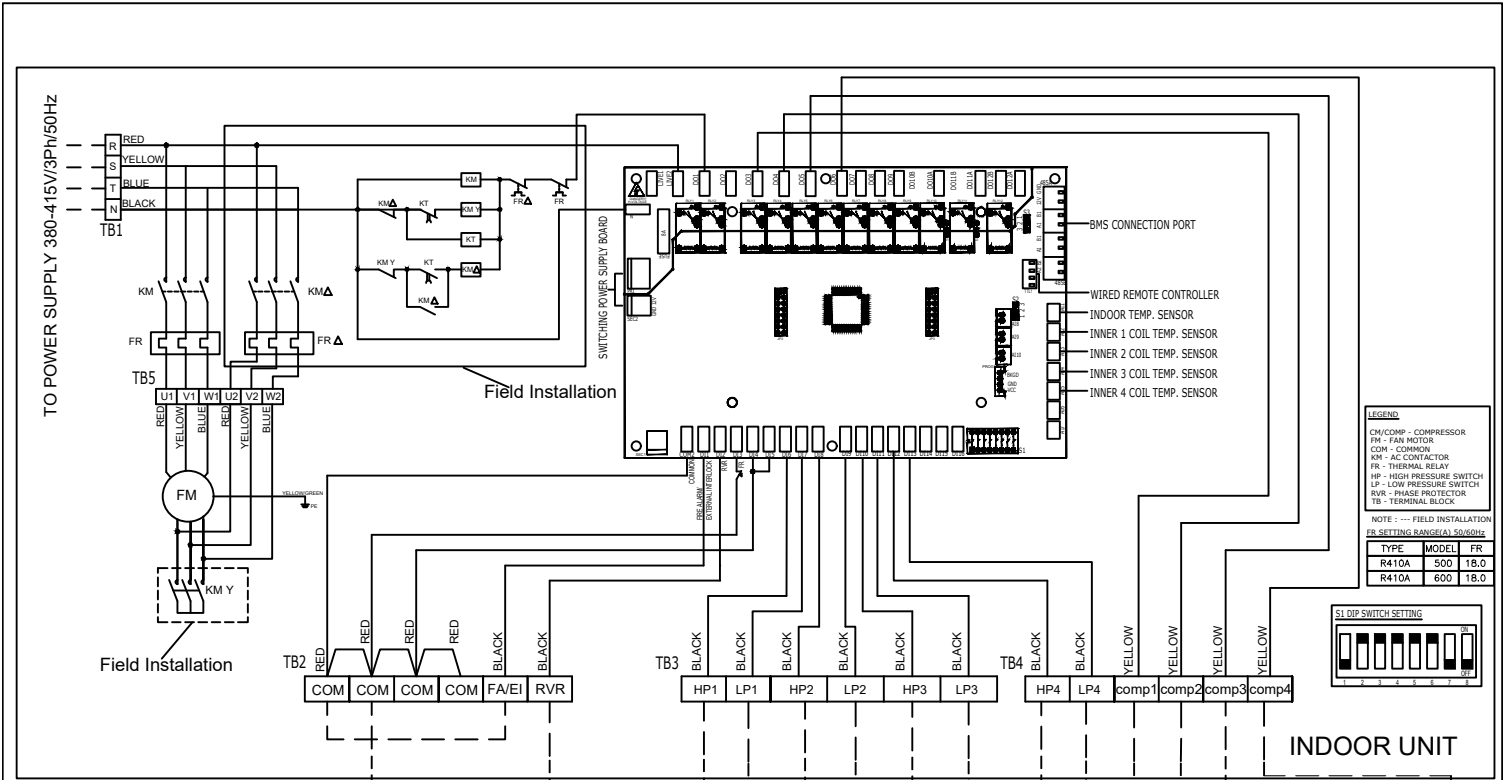

**Model: FASN200/250/300/350/400/450
(Without Control PCB)**

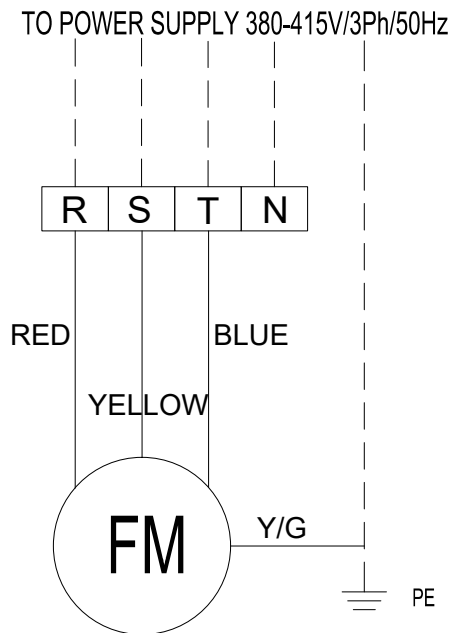

Note: - - - - - installation connection

Model: FASN500/600 (Without Control PCB)

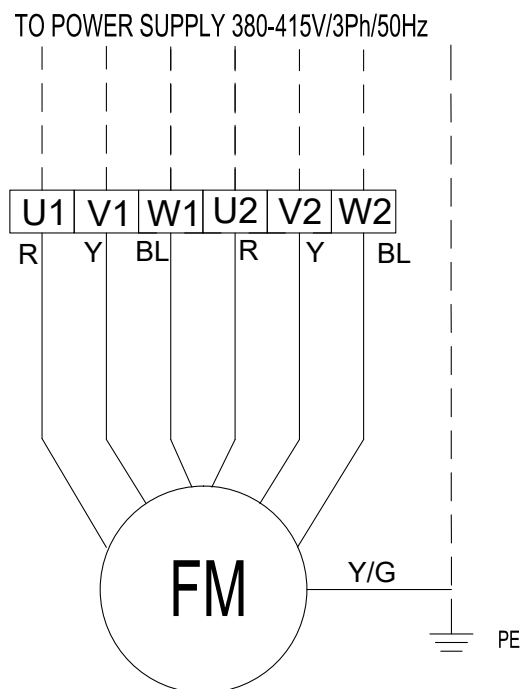

Note: - - - - - installation connection

Model: FASD200C/250C/300C (Without Control PCB)

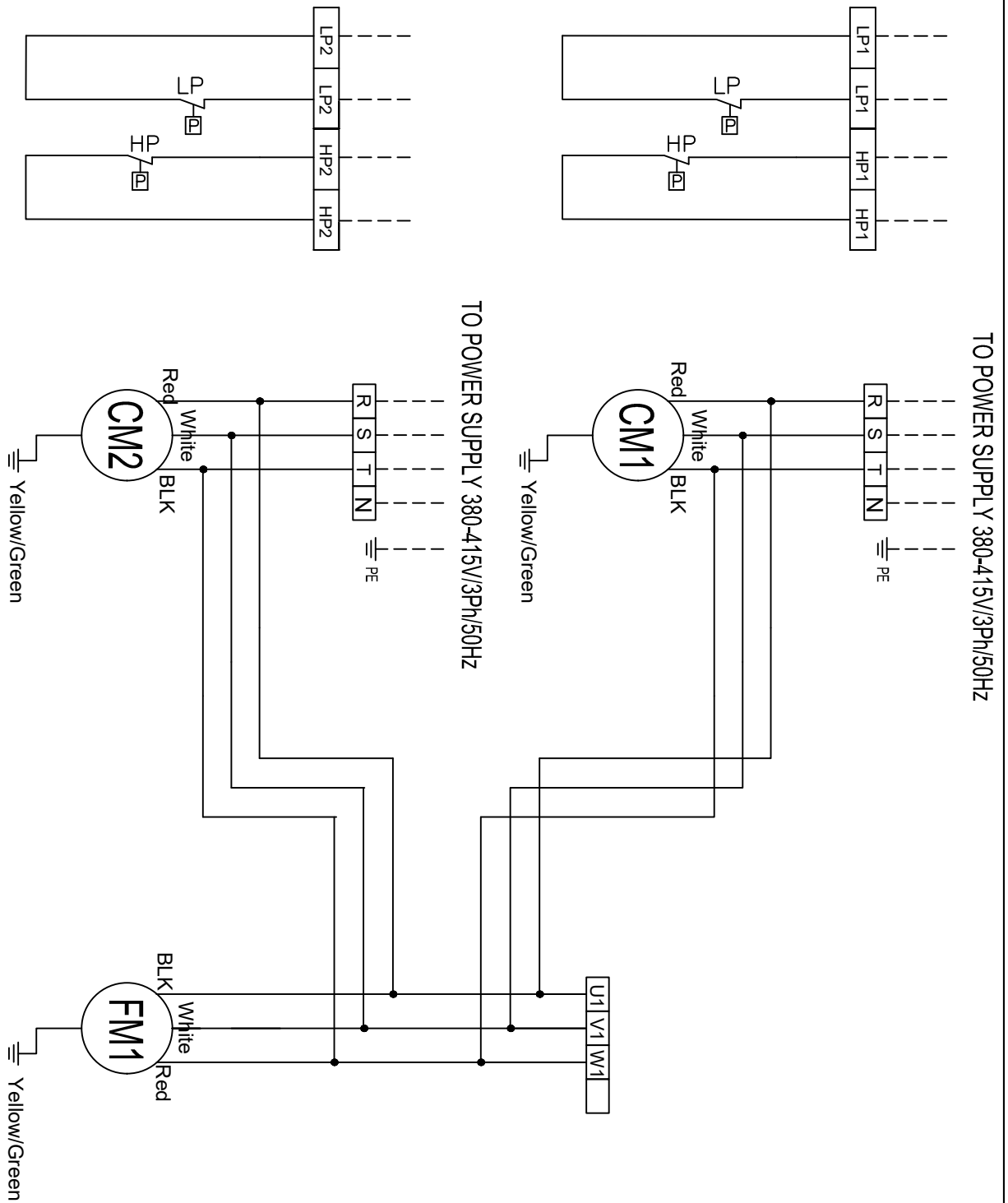

Note: ----- installation connection

Model: FASD400C/500C/600C(Without Control PCB)

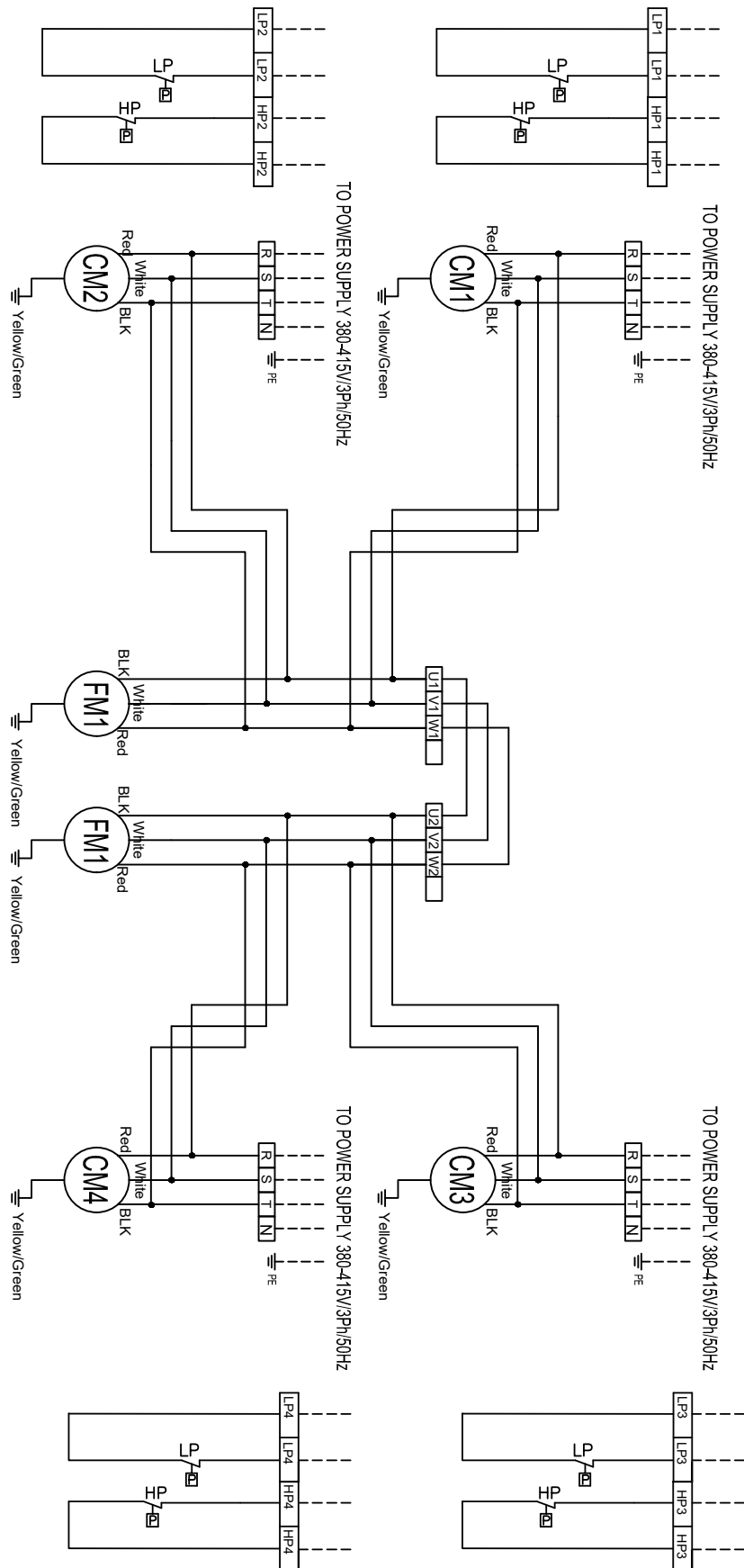

Note: installation connection

Installation

Unit should be installed by qualified technicians. Installation should adhere to local code and regulations.

 **Warning:**

Please pay attention to the following:

- Please check the equipment with your check list after receiving the unit.
- Please keep the unit horizontal and balanced before hanging up the unit.
- Please ensure proper equipment (e.g., fork lift, hoist, sling, etc.) is used when handling the unit.
- Please remove all packaging material after installation.

If there are any problems or the unit is damaged, please contact authorized dealer.

1. Indoor Unit Installation

Carefully plan the installation location with the following considerations:

- Easy distribution of air ducts.
- Space for connection of refrigerant pipes, wirings and water pipes.
- Ceiling/structure is strong enough to support the unit.
- For noise consideration, always install unit away from air-conditioned area.
- Always allow sufficient space for servicing and maintenance as shown in the following diagram:

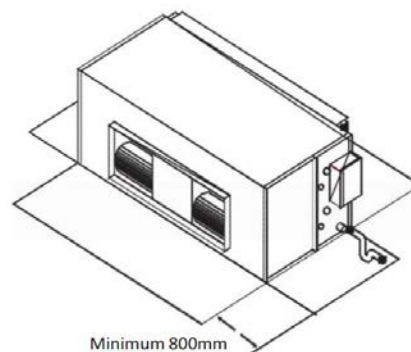

- Use the hanging rods to hang the unit through the holes provided. Strength of hanging rods must be able to support the total weight of the unit.
- During operation of the unit, there will be plenty of condensate water that needs to be discharged. In order to prevent overflow of condensate water, the water must be drained through condensate water pipe. Please ensure a gradient is maintained as shown in the following diagram.

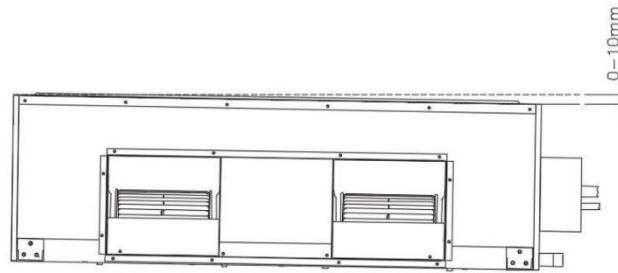

- To reduce noise transmission through hanging rod, it is recommended to install rubber dampers or isolators.
- Muffler can be used to reduce noise transmission through air duct if the unit needs to be installed near air-conditioned area.

Condensate drain pipe installation:

- For easy drainage of condensate water, drain pipe must be sloped downward at least at a gradient of 1:100.
- The drain pipe must have a U-bend.
- Drain pipe that runs under the ceiling or within the air-conditioned space should be insulated to prevent condensation of water. Choice of insulation material can be PE, PU or other appropriate insulation material.

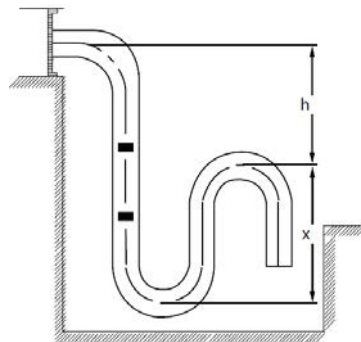

Air Ducting Installation:

- There are two types of discharge air-duct, namely rectangular and round ducts.
- Rectangular ducts can be connected to the discharge of the indoor unit directly. Refer to the dimension drawing of the unit to see the dimensions of the discharge.
- Flexible connection must be installed between air ducts and indoor unit to ensure quiet operation.
- A reducer is necessary to connect the round duct to the discharge of the unit.
- Design of supply and return air duct should strictly adhere to the maximum static pressure that can be delivered by the unit to avoid unsatisfactory unit performance and overload of fan motors.

2. Outdoor Unit Installation

To ensure the unit operates at optimum performance level and to maintain long life-span of components, the choice of location of unit and installation recommendations as listed below should be followed:

- The discharge air and intake air direction of outdoor unit should not be blocked to ensure there is no short circuiting of hot air.
- If there is more than 1 unit being installed at the same location, make sure that the discharge of one unit does not face the air intake of another.
- The location of installation should be well ventilated and avoid direct sunlight.
- Location of installation should be able to drain rain water or condensation water.
- Ensure the location of installation does not face strong wind and is free from dust.
- Do not connect duct to the outdoor fan discharge.
- Do not install the unit at location that is near corrosive materials or chemicals.
- Avoid installing the outdoor unit under the window.
- Ensure the discharge of air and noise generated during operation do not affect the surrounding neighbors.

Installation Clearance:

To provide sufficient service clearance and to ensure good air intake and discharge, please refer to the recommendation as follows:

Single Unit Installation FASD200C/250C/300C

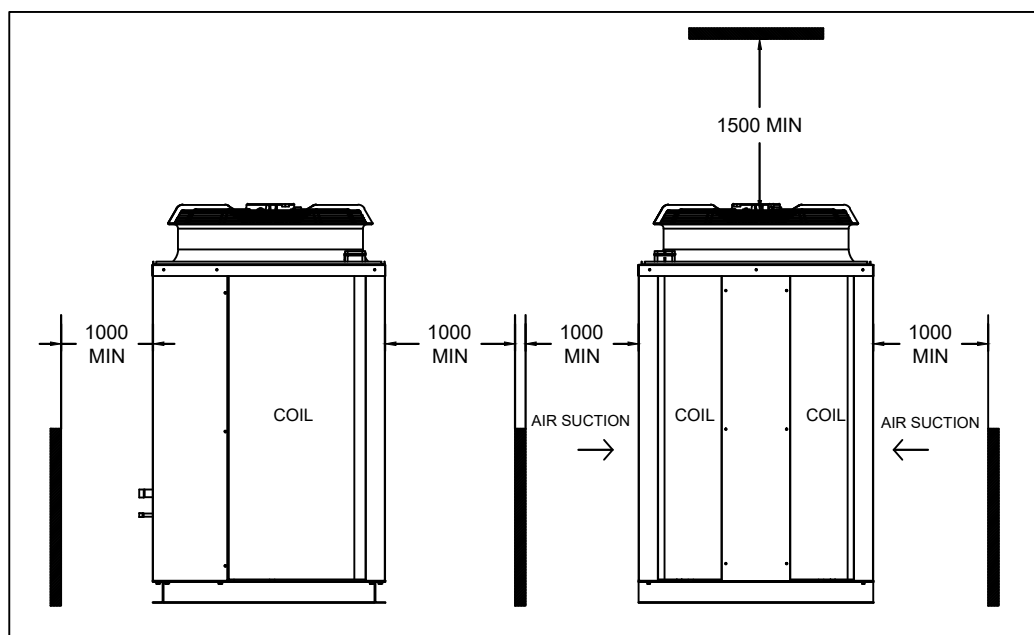

Single Unit Installation FASD400C/500C/600C

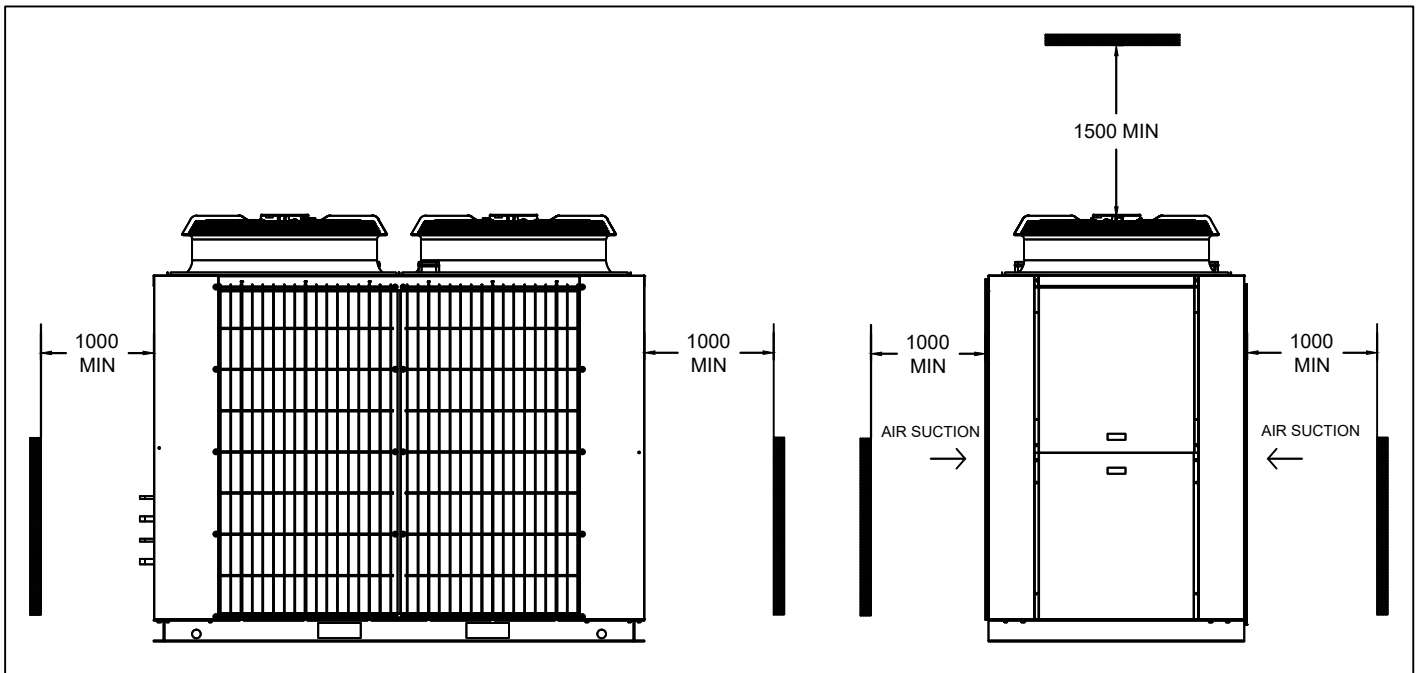

Multiple Units Installation FASD200C/250C/300C

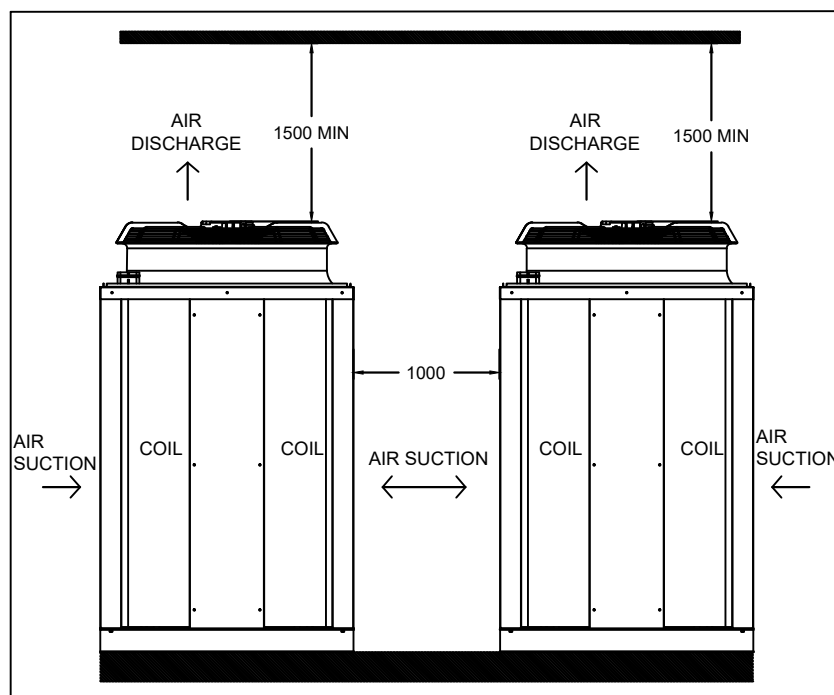

Multiple Units Installation FASD400C/500C/600C

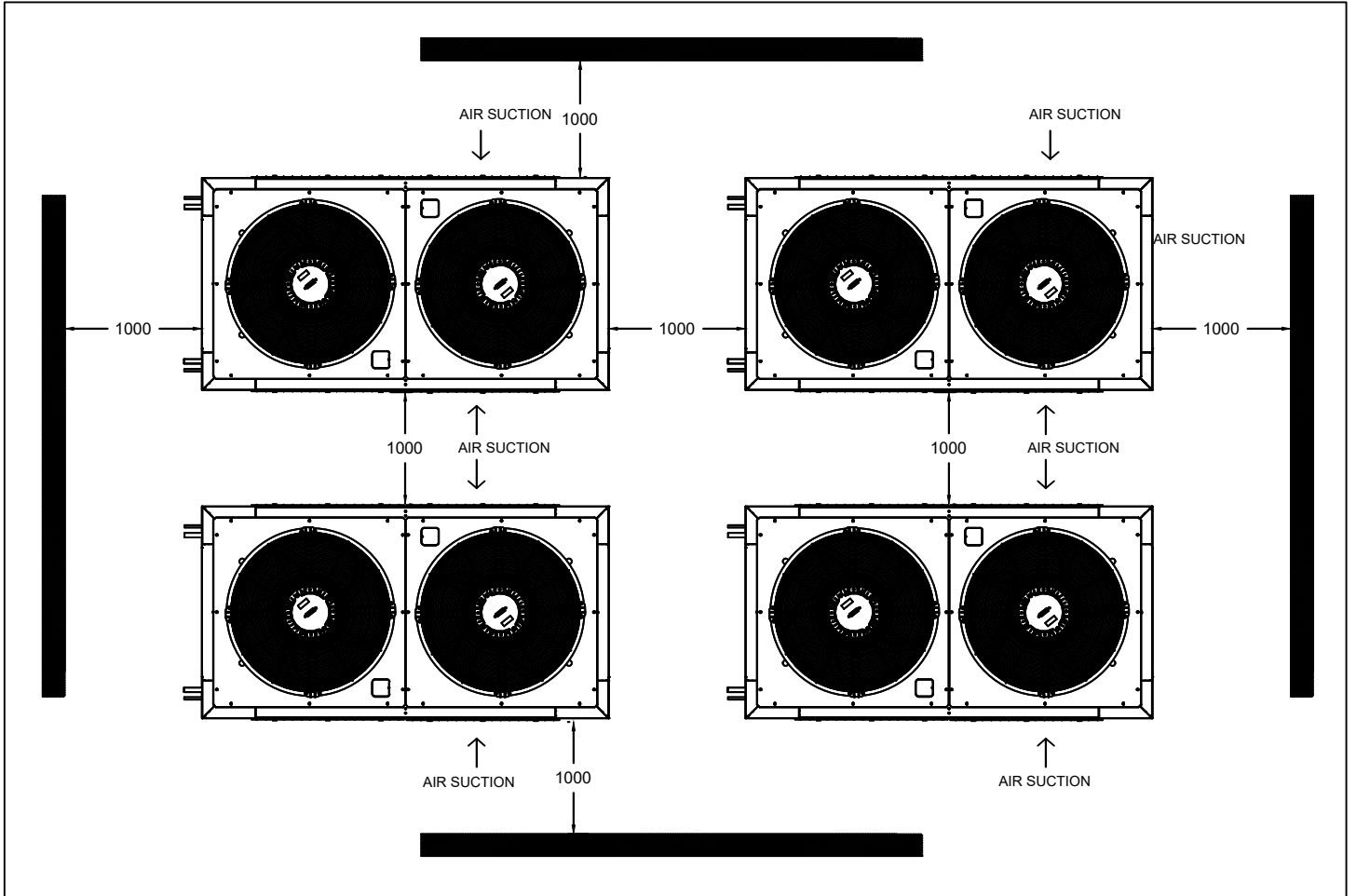

Electrical Parameter

MODEL		FASN/ FASD200C	FASN/ FASD250C	FASN/ FASD300C	
Power Source		V/Ph/Hz 380-415 /3/50			
Power Cord	Main Line (R/S/T)	Sectional area(mm2)	6	6	10
		Quantity	3		
	Null Line	Sectional area(mm2)	6	6	10
		Quantity	1		
	Ground Line	Sectional area(mm2)	6	6	10
		Quantity	1		
Fuse Size and MCB		A	50	63	80
		Quantity	1		

MODEL		FASN/ FASD400C	FASN/ FASD500C	FASN/ FASD300C	
Power Source		V/Ph/Hz 380-415 /3/50			
Power Cord	Main Line (R/S/T)	Sectional area(mm2)	16	25	25
		Quantity	3		
	Null Line	Sectional area(mm2)	16	25	25
		Quantity	1		
	Ground Line	Sectional area(mm2)	16	25	25
		Quantity	1		
Fuse Size and MCB		A	100	125	125
		Quantity	1		

Refrigerant Piping

Long refrigerant piping will affect the performance of the unit and shorten the lifespan of compressor. In the worst-case scenario, it will cause the compressor to break down. Special precaution needs to be taken to make sure that the maximum length of the piping strictly adheres to the recommended maximum pipe length and elevation in the following tables:

Model		Maximum Length (m)	Maximum Elevation (m)	Maximum Bends
FASN200	FASD200C	35	20	8
FASN250	FASD250C	35	20	8
FASN300	FASD300C	35	20	8
FASN400	FASD400C	35	20	8
FASN500	FASD500C	35	20	8
FASN600	FASD600C	35	20	8

CAUTION:

Bending must be carefully made so as not to crush the pipe. Use pipe bender

Vacuuming and Refrigerant Charging

Vacuuming is necessary to eliminate all moisture and air from the system.

Vacuuming

After the system piping is properly connected, vacuum the air conditioner system to at least 500 microns Hg.

Charging

Before charging, the vacuum must be held at 500 microns Hg for at least 15 minutes. After charging, operate the unit for 15 minutes, ensuring that refrigerant charges are of correct quantity by monitoring running current and suction and liquid line pressures. Suction and discharge pipe pressures should be in the region of 110~130 psig and 420~440 psig. After ensuring the system is correctly charged, remove flexible hose from charging nipples and replace with caps.

* Refrigerant pressure is based on 26.7 °C DB / 19.4 °C WB for indoor air temperature, 35.0 °C DB / 23.9 °C WB for ambient temperature.

Additional Charging

If the piping length is exceeding 10m, additional charge is necessary. The value of additional refrigerant charge (g) per 1 meter is as table below.

Outdoor model	FASD200	FASD250	FASD300	FASD400	FASD500	FASD600
Add.Charge ,g/m	105.0 X 2	118.5 X 2	145.5 X 2	105.0 X 4	118.5 X 4	145.5 X 4

Note:

1. Failure to add proper amount of additional refrigerant may result in reduced performance.
2. FASD200 to FASD600 consists of more than one refrigerant systems.

Attention:

Outdoor unit is not factory pre-charged with refrigerant.

Lifting Method

Each product design to be brought in safety. When the unit is to be lifted and moved, attach ropes to the suspension plates(4pcs) provided on the top of the unit. When the unit is lifted, the center of gravity tends to shift the unit to one side and so balance as shown in the figure below should be achieved. The angles at which the ropes suspended the unit should be at least 60° at the compressor end and at least 45° at the condenser end. Care should be taken to avoid contact with the main unit while carrying. Hook as directly aligned over the center of gravity as possible.

Example for the indoor unit shown as figure:

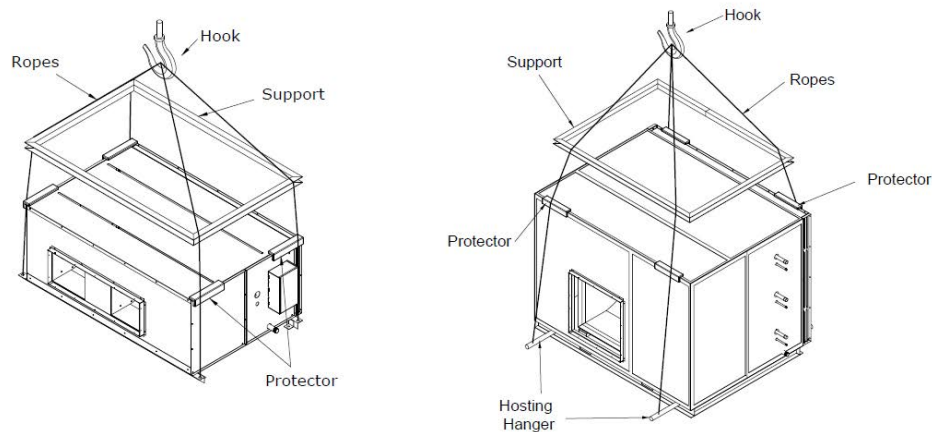

Example for the outdoor unit shown as figure:

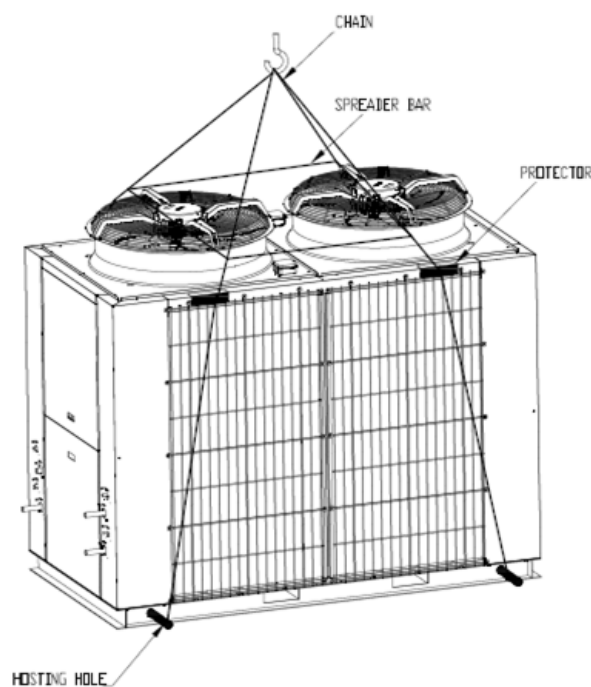

Servicing and Maintenance

1. Indoor Unit

Air Filter

- The filter must be cleaned regularly and the frequency of cleaning is to be determined by the degree of pollution of the environment of application. When washing the filter, first tap it gently to remove larger particle, and then rinse the filter in detergent and warm water. The filter must be dried before it is used. The filter is recommended to be installed before the air grille or the indoor coil. If there are any problems or the unit is damaged, please contact authorized dealer.

Motor

- It is not necessary to lubricate the motor for servicing and maintenance.

Heat Exchanger

- After in use for a while, the surface of the coil may collect dust, dirt or other undesirable substances. It is recommended to clean the aluminum fins of the coil using a nylon brush or vacuum cleaner. If compressed air is available, it can be used to clean the coil by direct blowing. However, care must be taken not to damage the fins.

Drain Pipe

- Check the drain pipe regularly to prevent blockages by alien substances.

2. Outdoor Unit

Under normal operating conditions, outdoor unit should be checked quarterly and the coil surface should be washed. If the outdoor unit is installed at location which is oily, smoky and dusty, regular service should be done by a technician to make sure that the heat exchanger is always in optimum condition.

Warning!

Do not use oxygen, acetylene, poisonous gas or other gas that will cause explosion under high temperatures and pressure for leak checking. Instead, use nitrogen or R410A for air leakage test.

Troubleshooting

Fault	Possible Cause	Solution
Abnormal Noise	Blower blade or blower shaft loose.	Tighten the shaft.
	Blower or blower housing dirty.	Clean blower.
	Duct or modulating valve loose.	Repair duct and modulating valve.
	Fan belts not align or loose.	Align or tighten fan belt.
	Nuts and bolts for motor, fan or motor base loose.	Tighten the nuts and bolts.
	Flexible duct at intake / discharge too tight.	Re-adjust the flexible duct. Change if necessary.
	Fan operating point is not optimum.	Re-select fan motor or pulley.
	Lubrication is bad or no lubrication.	Clean the bearing and re-apply lubrication oil.
	Deflector too small or duct elbow over turn to produce noise.	Change deflector.
	Fan too small.	Reselect fan.
Supply Air Too Low	Dirty filter.	Clean or change filter.
	Leakage in duct.	Check and seal the leakage.
	Air duct is blocked or air vent is not open.	Clear the air duct or open the air vent.
	Fan rotates in wrong direction.	Reverse the phase of power supply.
	RPM too low.	Change fan motor or pulley.
	Fan or fan motor undersized.	Change fan motor or pulleys.
Supply Air Too High	Oversized fan or motor.	Reselect fan motor or pulley.
	RPM too high.	Change fan motor or pulleys.
Air Velocity Too High	Air velocity too high at vent.	Extend vent area.
	Airflow unstable.	Change vent size or add extra deflector to rectify airflow.
Insufficient Fresh Air	Not enough fresh air supply.	Fully open fresh air vent.
		Clean fresh air filter.
		Increase cross-section area of fresh air duct.

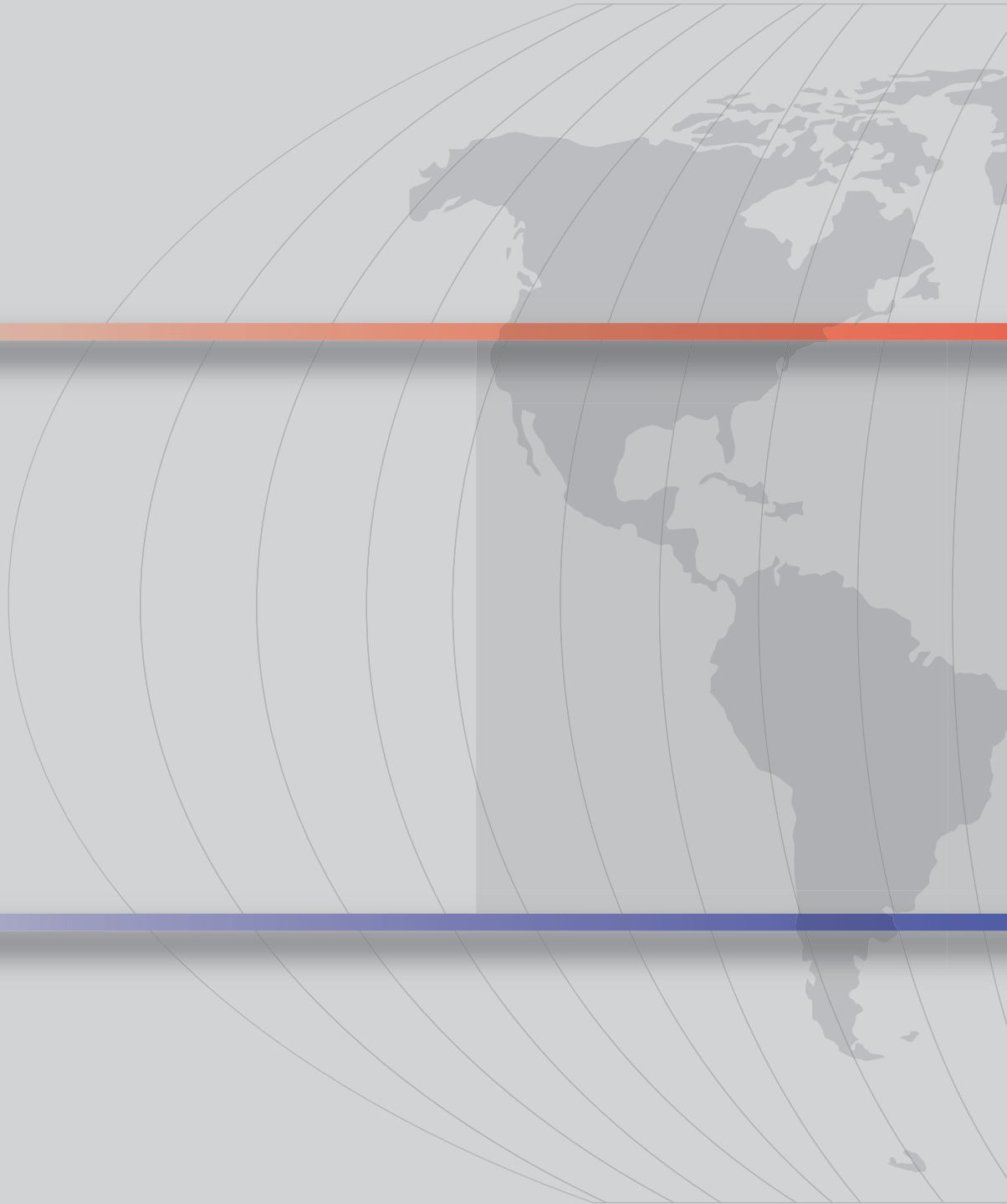

A member of FRIMEC International Group