

# WS

**Water cooled chiller, reversible water side and Evaporating unit  
For indoor installation  
Screw compressor and plate exchanger  
Cooling capacity 148 - 699 kW  
Heating capacity 165 - 777 kW**

## R134a



Aermec participates in the EUROVENT Program: LCP  
The products of interest can be found on the website [www.eurovent-certification.com](http://www.eurovent-certification.com)

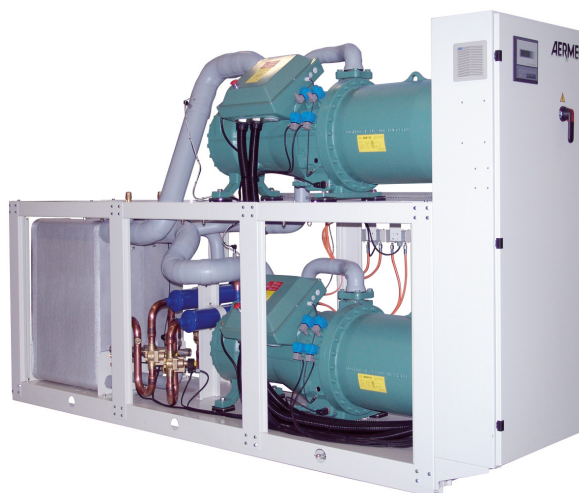

- **HIGH EFFICIENCY ALL IN CLASS A EUROVENT**
- **OPTIMISED FOR LOW CONDENSER TEMPERATURES**
- **REVERSIBLE ON HYDRAULIC SIDE IN HEAT PUMP**
- **GEOHERMAL APPLICATIONS**

### Features

Units for internal installation offering chilled/hot water (reversible on the water side).

Compact and flexible, perfect alignment to the requested load thanks to an accurate control algorithm. The screw compressors are optimized for low condensing temperatures, plate heat exchangers are applied on both the system and source side.

The base and frame are in steel treated with anti-corrosion polyester paint.

The technical solutions applied, aimed at maximizing efficiency and quality levels, allow EER levels of  $\geq 5,05$  to be achieved (class A according to Eurovent).

#### Versions

**WS** Standard reversible water side

**WS\_E** Evaporating unit

- High efficiency, low noise screw compressors with modulating capacity control from 40 to 100% with standard thermostatic expansion valve. (25 to 100% with electronic expansion valve option)
- For all versions, if required, it is available the integral acoustic enclosure, which can further reduce the sound level.
- Unit available with total recovery / Desuperheater
- Compressor discharge and liquid line isolating valves
- Current transformer as standard for each compressor
- Modulating capacity control microprocessor system
- Independent control for individual circuits
- Electrical panel with all cables numbered
- Modulating capacity control with dynamic

display of refrigeration capacity

- "Always Working" function. In the case of critical conditions the unit will not stop but automatically adjusts operation
- Automatic set point compensation using analogue inputs 4-20 mA or 0-10 V or an external air sensor.
- Auto-adaptive differential to ensure correct compressor operating timers.
- PDC (Pull Down Control) system which prevents capacity loading when the water temperature quickly approaches the set point
- DL (Demand Limit) system permits current limiting of the unit during times of insufficient electrical power (load peaks or generator operation).

### Accessories

- **AER485P1**: RS-485 interface for supervision systems with MODBUS protocol.
- **PRV3**: Remote control of the chiller operating functions.
- **RIF**: Power factor correction. Connected in parallel to the motor allowing about 10% reduction of input current. Must be requested at time of order and is available factory fitted only.
- **AVX**: Spring anti-vibration mounts.
- **AERWEB300**: Accessory AERWEB allows remote control of a chiller through a common PC

and an ethernet connection over a common browser; 4 versions available:

- AERWEB300-6: Web server to monitor and remote control max. 6 units in RS485 network;
- AERWEB300-18: Web server to monitor and remote control max. 18 units in RS485 network;
- AERWEB300-6G: Web server to monitor and remote control max. 6 units in RS485 network with integrated GPRS modem;
- AERWEB300-18G: Web server to monitor and remote control max. 18 units in RS485 network

with integrated GPRS modem;

- **MULTICHILLER**: Control system for multiple parallel installed constant flow chillers providing individual chiller on/off and control capability.
- **AKW: ACOUSTIC KIT**: Allows further unit sound reduction using an optimised enclosure made from a high density ecological material.

## Accessory compatibility

Mod	Vers.	0601	0701	0801	0901	1101	1202	1402	1602	1802	2002	2202	2502	2802
AERWEB300		•	•	•	•	•	•	•	•	•	•	•	•	•
MULTICHILLER		•	•	•	•	•	•	•	•	•	•	•	•	•
AER485P1		•	•	•	•	•	•(x2)	•(x2)	•(x2)	•(x2)	•(x2)	•(x2)	•(x2)	•(x2)
RIF		-	161	161	201	241	161(x2)	161(x2)	161(x2)	201(x2)	201-241	241(x2)	301(x2)	301(x2)
PRV3		•	•	•	•	•	•	•	•	•	•	•	•	•
AVX	°/L	651	651	652	652	656	658	658	658	659	667	661	661	661
AKW	L	•	•	•	•	•	•	•	•	•	•	•	•	•

## Unit Configurator

By suitably combining the numerous options available it is possible to configure each model in such a way as to meet the most demanding of system requirements.

**Field**    **Code**  
**1,2**      **WS**

**3,4,5,6**    **Size**  
0601-0701-0801-0901-1101-1202-1402-1602-1802-2002-2202-2502-2802

**7**            **Field of use (1)**  
° Standard (temperature of water produced up to +4 °C)  
**X** Electronic thermostatic valve (temperature of water produced up to +4 °C)  
**Y** Low temperature (temperature of water produced from +4°C a -6°C)  
**Z** Low temperature electronic thermostatic valve (temperature of water produced from +4°C a -6°C)

**8**            **Model**  
° Only cooling

**9**            **Heat recovery (2)**  
° Without heat recovery  
**D** With desuperheater  
**T** With total recovery

**10**          **Versions**  
° Standard  
**L** Low noise

**Heat exchanger**  
° PED regulation  
**E** Evaporating unit (delivered with holding charge only)

**11**          **Power supply**  
° 400/3/50Hz  
**8** 400V/3/50Hz with circuit breakers  
**2** 230V/3/50Hz with fuses  
**4** 230V/3/50Hz with circuit breakers  
**5** 500V/3/50Hz with fuses  
**9** 500V/3/50Hz with circuit breakers

(1) Y/Z not available with D, T

(2) T not available with E

## Technical Data

WS - °/L		0601	0701	0801	0901	1101	1202	1402	1602	1802	2002	2202	2502	2802	
		400V/3/50Hz													
12°C / 7°C	Cooling capacity	(1) kW	148	187	212	234	299	308	369	421	469	545	599	653	699
	Total input power	(1) kW	29	37	42	46	59	61	73	83	93	107	117	128	137
	EER	(1)	5,06	5,09	5,06	5,07	5,09	5,09	5,06	5,06	5,06	5,10	5,11	5,10	5,11
	ESEER	(1)	5,62	5,72	5,98	5,90	5,88	5,98	6,04	6,12	6,04	5,83	5,96	6,03	5,97
	Cooling Energy Class Eurovent	(1)	A	A	A	A	A	A	A	A	A	A	A	A	A
	Water flow rate system side	(1) l/h	25421	32148	36495	40212	51430	53088	63476	72492	80788	93813	103143	112508	120438
40°C / 45°C	Pressure drop	(1) kPa	23	17	15	16	18	33	25	27	30	33	35	39	44
	Water flow rate geothermal side	(1) l/h	30001	37968	43166	47545	60777	62583	75000	85654	95422	110603	121544	132559	141772
	Pressure drop	(1) kPa	33	23	22	22	25	47	36	39	43	48	52	58	65
	Heating capacity	(2) kW	159	198	225	248	318	330	389	445	496	575	632	695	743
	Total input power	(2) kW	37	46	52	58	73	78	91	104	115	133	145	160	170
	COP	(2)	4,24	4,33	4,29	4,31	4,34	4,25	4,29	4,29	4,30	4,34	4,35	4,35	4,37
	Water flow rate system side	(2) l/h	27169	33945	38474	42555	54526	56400	66645	76147	84899	98460	108201	118879	127104
	Pressure drop	(2) kPa	27	19	17	18	21	39	29	31	35	39	42	47	53
	Water flow rate geothermal side	(2) l/h	21193	26598	30056	33295	42740	44032	52095	59528	66427	77278	84976	93439	100083
	Pressure drop	(2) kPa	16	11	10	11	12	23	17	18	20	23	24	27	31
<b>Performance under average climatic conditions (Average)</b>															
Pdesignh	(3)	229	290	330	363	/	/	/	/	/	/	/	/	/	
SCOP	(3)	5,98	6,10	6,30	6,25	/	/	/	/	/	/	/	/	/	
ηs	(3)	231	236	244	242	/	/	/	/	/	/	/	/	/	

### Date (14511:2013)

- (1) Water system side (in/out) 12°C/7°C; Water geothermal (in/out) 30°C/35°C  
(2) Water system side (in/out) 40°C/45°C; Water geothermal (in/out) 10°C/5°C  
(3) Efficiencies for low temperature Applications (35°C), according to regulation n°811/2013 Pdesignh ≤ 400kW

WS - E/LE		0601	0701	0801	0901	1101	1202	1402	1602	1802	2002	2202	2502	2802	
12°C / 7°C	Cooling capacity	(4) kW	134,50	167,91	189,23	216,74	264,40	276,73	333,22	380,99	431,69	489,77	542,53	591,70	629,62
	Total input power	(4) kW	34,67	42,20	48,25	54,95	67,05	69,32	84,39	96,50	109,90	122,01	134,11	146,84	157,00
	EER	(4)	3,88	3,98	3,92	3,94	3,94	3,99	3,95	3,95	3,93	4,01	4,05	4,03	4,01
	Water flow rate system side	(4) l/h	23108	28849	32512	37238	45428	47546	57251	65458	74169	84147	93212	101661	108175
	Pressure drop	(4) kPa	18	13	12	12	14	25	19	20	23	25	27	30	34

- (4) Water system side (in/out) 12°C/7°C; Condensing temperature 45°C

		0601	0701	0801	0901	1101	1202	1402	1602	1802	2002	2202	2502	2802	
<b>Electrical data</b>															
Total input currente (cooling)	o	A	55,8	66,7	74,5	83,3	95,3	110,0	133,2	149,2	167,1	179,0	190,5	218,5	235,2
Total input currente (heating)		A	68,0	79,2	89,1	100,5	117,0	133,6	158,4	178,5	201,5	218,1	234,1	265,9	285,6
Total input currente (cooling)	E	A	63	75	85	96	111	127	151	170	192	207	222	252	270
Maximum current (FLA)		A	72	84	96	109	130	144	169	191	218	239	260	294	315
Starting current (LRA)		A	218	267	290	350	439	265	326	355	421	510	518	608	700
<b>Screw Compressor</b>															
Compressors / Circuit	n°/n°	1/1	1/1	1/1	1/1	1/1	2/2	2/2	2/2	2/2	2/2	2/2	2/2	2/2	
Refrigerant	Type	R134a													
<b>Heat exchanger system side</b>															
Exchanger	Type/n°	Plate/1													
hydraulic connections (In/Out)	(4) Type/Ø	2"½	2"½	2"½	2"½	2"½	2"½	2"½	2"½	3"	3"	3"	3"	3"	
<b>Heat exchanger source side</b>															
Exchanger	Type/n°	Plate/1													
hydraulic connections (In/Out)	(4) Type/Ø	2"½	2"½	2"½	2"½	2"½	2"½	2"½	3"	3"	3"	3"	3"	3"	
<b>Sound data</b>															
Sound power level	o	dB(A)	85	86	86	86	92	88	89	89	89	93	95	95	95
Sound pressure level		dB(A)	53	54	54	54	60	56	57	57	57	61	63	63	63
Sound power level	L	dB(A)	77	78	78	78	84	80	81	81	81	85	87	87	87
Sound pressure level		dB(A)	45	46	46	46	52	48	49	49	49	53	55	55	55

**Sound power** Aermec determines sound power values on the basis of measurements made in accordance with UNI EN ISO 9614-2, as required for Eurovent certification.

**Sound pressure** Sound pressure in free field, at 10 m distance from the external surface of the unit (in accordance with UNI EN ISO 3744).

**Note:** For more information, refer to the selection program or the technical documentation available on the website [www.aermec.com](http://www.aermec.com)

## Dimensions (mm)

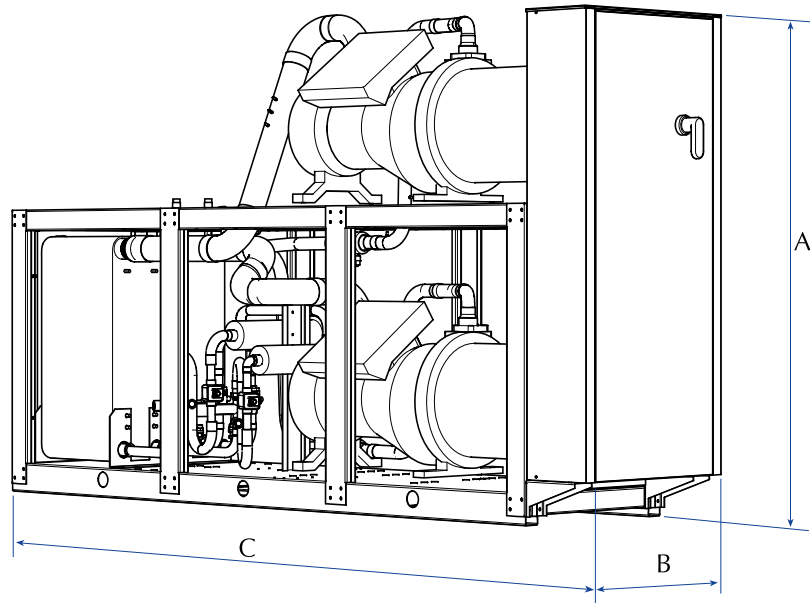

		0601	0701	0801	0901	1101	1202	1402	1602	1802	2002	2202	2502	2802
<b>WS °</b>														
Height	A mm	1775	1775	1775	1775	1775	1975	1975	1975	2005	1985	2065	2065	2065
Width	B mm	810	810	810	810	810	810	810	810	810	810	810	810	810
Length	C mm	2960	2960	2960	2960	3360	2960	2960	2960	2960	3360	3360	3360	3360
Weight - °	kg	1101	1251	1301	1357	1788	1738	2072	2141	2213	2649	3051	3131	3131
<b>WS L</b>														
Height	A mm	1775	1775	1775	1775	1775	2120	2120	2120	2120	2120	2120	2120	2120
Width	B mm	810	810	810	810	810	810	810	810	810	810	810	810	810
Length	C mm	2960	2960	2960	2960	3360	2960	2960	2960	2960	3360	3360	3360	3360
Weight - L	kg	1229	1379	1429	1485	1934	1966	2300	2369	2441	2906	3308	3388	3388