

V2-GAN-A125

GATE VALVE, NON RISING STEM

PRODUCT SPECIFICATION SHEET



FEATURES

- Brass body
- Non Rising Stem
- Forged brass stem
- NPT / BSP threading
- Full Port

SPECIFICATIONS

Valve sizes: ½" to 2" (Threaded ends)
 Nominal pressure: 200 psi from 0 °C to 100 °C
 (Water or non-corrosive liquid)

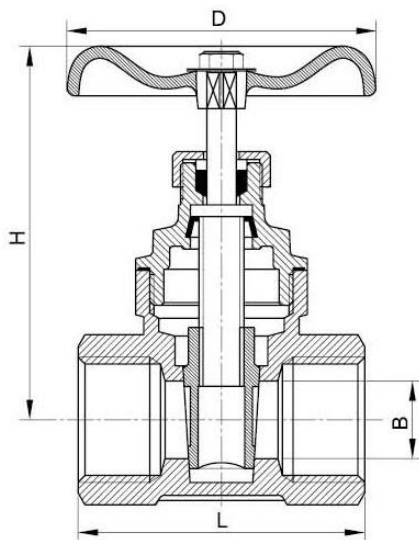

NO.	DESCRIPTION	MATERIAL
1	Wheel Nut	Stainless Steel
2	Name Plate	Aluminum Plate
3	Handwheel	Cast Iron
4	Stem	Brass
5	Packing Nut	Brass
6	Gland	Brass
7	Packing	Teflon
8	Lock Nut	Brass
9	Bonnet	Brass
10	Disc	Brass
11	Body	Brass

DIMENSIONS in (mm)

Size	Part No.	Part No.	L	B	H	D
	For NPT Threading	For BSP Threading				
½"	V2-GAN-A125-A050-NF	V2-GAN-A125-B015-NF	46	15	69.5	55
¾"	V2-GAN-A125-A075-NF	V2-GAN-A125-B020-NF	49	19	80.5	60
1"	V2-GAN-A125-A100-NF	V2-GAN-A125-B025-NF	57	25	91.5	72
1 ¼"	V2-GAN-A125-A125-NF	V2-GAN-A125-B032-NF	63	32	108	72
1 ½"	V2-GAN-A125-A150-NF	V2-GAN-A125-B040-NF	65	38	122.5	80
2"	V2-GAN-A125-A200-NF	V2-GAN-A125-B050-NF	75	50	147	100