



Automatic

TUBE CLEANING

system



HYDRO TECHNOLOGY SOLUTIONS

Successful Deployments at Top Companies Around the World

CQM Systems has successfully installed and supported innovative fouling mitigation and cleaning products at such recognized companies as:



TOYOTA



mazda



HYUNDAI SONY



LG



DAEWOO



SAMSUNG



FUJITSU



BOSCH
Invented for life



MOTOROLA

PHILIPS



Sheraton
HOTELS & RESORTS



Hilton

HYATT



TEVA
TEVA PHARMACEUTICALS USA



Holiday Inn
HOTELS - RESORTS



Nestlé



EFES
Pilsen

Introduction

Worldwide Innovative Leader

CQM Systems is a worldwide leader in providing the most innovative and efficient water treatment systems available. Our environmentally friendly solutions for the treatment of water-based heat exchange processes have applications in commercial and institutional HVAC to power generation and refining to industrial process water treatment.



Global Experience and Proven Success

CQM Systems was founded in 1996 to develop and market cost-effective fouling mitigation and cleaning products for commercial and institutional HVAC users, industrial water processes, refining and power generation facilities. Drawing from extensive experience, CQM systems' products have proven their value to hundreds of clients worldwide in close to 3,000 installations across 22 countries.



CQM System- Innovative, Affordable, Green Water Treatment and Heat Exchanger Cleaning Solutions

Satisfied Customers

CQM Systems products provide our customers with reliable, efficient, and affordable solutions for their HVAC and industrial water treatment systems. The savings driven by both the ATCS and SRS products typically produce very high ROIs that make the decision to deploy these innovations easy for our customers.

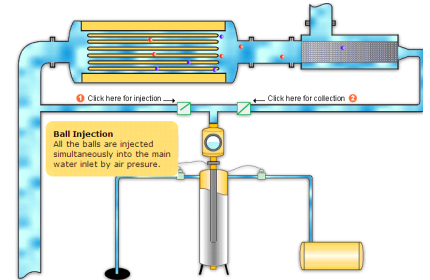

Innovative Products.

CQM System offers an array of transformational products that work separately or together to dramatically improve HVAC and industrial water process efficiency. CQM's ATCS is the key to energy-saving, cost-effective tube cleaning and the CQM SRS Water Treatment System is a chemical-free, environmentally-friendly solution for removing scale and keeping water circuits clean.

Content

Introduction	2
Features and Benefits	4
Current situations and solutions	5
How does the ATCS work?	9
Air Driven	9
Pump Driven	10
Applications and Industries	11
Sizing and Selection	15
System Components	16
Model Table with Dimension	18

CQM SYSTEMS PRODUCT BENEFITS:

ATCS:

Environmentally Friendly
 Efficient
 Non-intrusive, Online
 Complete Cleaning
 Simple Design
 Accurate Process Control
 No Downtime
 Simple Maintenance



ATCS (Automatic Tube Cleaning System)

Our proprietary ATCS products is most efficient automatic online solution for keeping shell and tube heat exchangers continuously clean and operating at design efficiency levels. The system is paired with either a new or existing heat exchanger and operates by periodically ejecting purpose-built sponge balls into the tubes. The balls are designed to be 5% larger than the tube themselves. The water flow pushes the balls through the tubes, which are efficiently rubbed clean and any build-up.

Clean Water, Clear Savings

CQM solutions clean your water-cooling system without wasteful and harmful chemicals. Plus, you save energy, water and money — leaving you with a clear conscience.



- **Wide Range of Sizes:** from 7 to 70mm diameter balls, catering to both small and large applications (from air conditioning to large industrial plants)



Quick Installation Process

The ATCS typical installation time is less than 20 man-hours. The only operations that require system line shutdown is the assembly of the trapping unit on the Heat Exchanger's tube side outlet pipe and cutting a small hole for the ball injection on the Heat Exchanger's tube side inlet pipe.

All other installation activities can be performed while the system is operating.

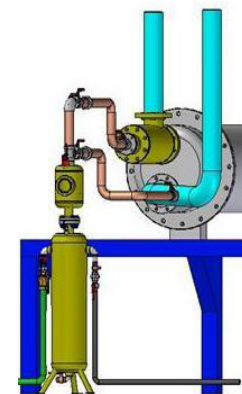

CQM Advantages

Water and energy-saving: Our systems reduce comfort cooling energy costs by up to 25% and cooling tower bleed water consumption by up to 80%

- **Money-saving:** Our systems improve energy efficiency, reduce maintenance and extend the life of your capital equipment — saving you money in the long run.
- **Sustainable:** Our solutions are chemical-free, reducing safety, health and environmental concerns.
- **Proven:** Our patented products have already proven their value to hundreds of clients worldwide in close to 3,000 installations in 22 countries.
- **Simple:** Our systems are designed for reliability. Moving parts are minimized to prevent mechanical failure and produce world-class performance.
- **Wide Range of Applications:**
 - Sweet/fresh water to sour corrosive chemical solutions
 - Bulk Fluid/ tube skin temperature: from -60 to 280oC (-76 to 540oF)
 - Fluid specific gravity of 0.3 to 11
 - No limit to fluid pressure
 - Vertical or horizontal flow alignment
- **Customized Cleaning Periods** for high level performance, better control and minimized ball deterioration.

Current Situations

Heat Exchanger Fouling

Heat exchanger fouling, the growth of deposits on heat transfer surfaces, decreases performance and productivity. It is extremely costly to companies, industry and power plants that are constantly seeking methods to eliminate it. Several systems exist that combat the problem—offline or online.

Fouling and corrosion as a result of the deposition of unwanted materials on heat transfer surfaces.



Environmental impacts owing to greenhouse emission as a consequence of poor energy conversion and discharge of anti-foulant chemicals (fouling inhibitors).

From economy point of view, the formation of process-related deposits on heat transfer surfaces bears an estimated enormous price tag of about **0.25% of the GDP of industrialized countries** (Source *United Nations*)

Low efficiency on account of poor performance of energy conversion in plants and the old technologies that have been in practice for heat transfer and condensation.

Effect of Scale on Energy Consumption of Chillers

Relative Horsepower per Ton in Percent at 40F Suction

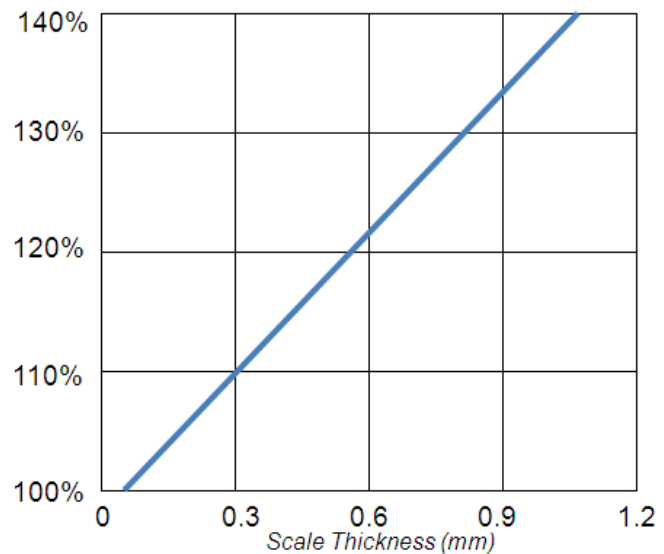

Source: Philip Kotz "Clean system Approach to Air Conditioning Heating, Piping and Air Conditioning Journal"

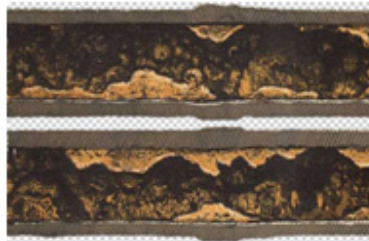

What Have Been Done In Real Life Now?

Offline Solutions / Periodic Cleaning

The offline solution requires shutting down the process for the cleaning. It uses chemicals or mechanical means to do the job. Using chemicals that are harmful to the environment requires extreme safety measures and specialized disposal. Between cleaning treatments, fouling accumulates and hampers performance. These drawbacks make the offline methods of heat exchanger cleaning expensive, cumbersome and inefficient.

Waste your water-cooling system with wasteful and harmful chemicals. Plus, you waste energy, water and money. Costly process shutdowns or chemical treatments

Condenser and evaporator tube fouling, steam condensers, and shell and tube heat exchangers in either steam or combined cycle plants is **caused by dirt, carbonates, salts, metals and microorganisms carried by the water.**

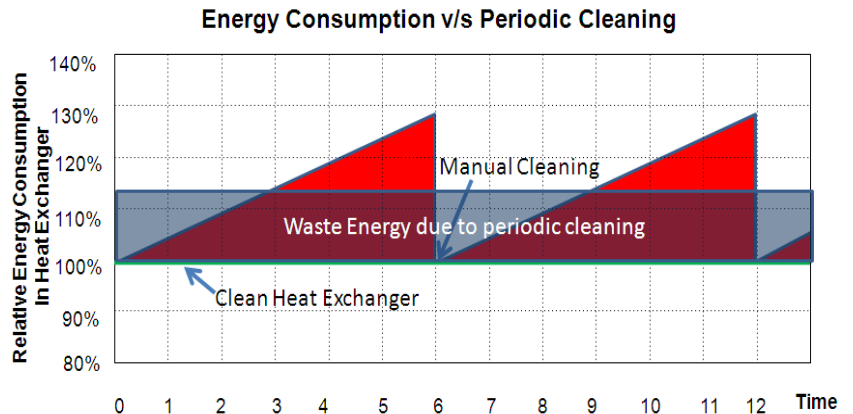

Fouling Thermal Resistance (hr)(sq ft) (deg F temp diff)/t	Overall Transfer Coefficient Btu/(hr)(sq ft) (deg F Temp)*	Thickness Scale Approx. (mm)	Increase in Heat Transfer Area Req'd. (Approximate %)
Clean tube	850	0	0
0.0005	595	0.15	45
0.001	460	0.30	85
0.002	315	0.60	170
0.003	240	0.90	250

Assume a mean value for the thermal conductivity of scale of 1.0 Btu/(hr)(sqft)(deg F/ft), the overall heat transfer coefficient U selected for this illustration is typical for a water cooled refrigerant condenser. However, because it is possible to have different overall heat transfer coefficients

*sq ft inside surface of heat exchanger tube

What Is The Solution?

Online Method / Continuous Cleaning

The online method, on the other hand, is both environmentally sound and extremely cost effective. Online cleaning doesn't require shutting down since it is an ongoing process. Fouling doesn't accumulate because the cleaning procedure is constantly taking place. In short, online heat exchanger cleaning is the most resourceful option available today.

It cleans continually without shut-down and interruption to the heat exchange process. Minimum wear and tear make maintenance cost almost down to **ZERO**. At the same time, mechanical and chemical cleaning will be minimized.

CQM Can Combat the "Fouling Factor" on Chiller Efficiency

In HVAC applications, fouling of the chiller condenser tubes has substantial impact on the power consumption of the compressor. It's not uncommon to find chillers that appear to be in good working order operating at a fouling factor of 0.0025 hr-ft²-F/Btu or higher — causing compressor power consumption to increase by 25% or more. [1]

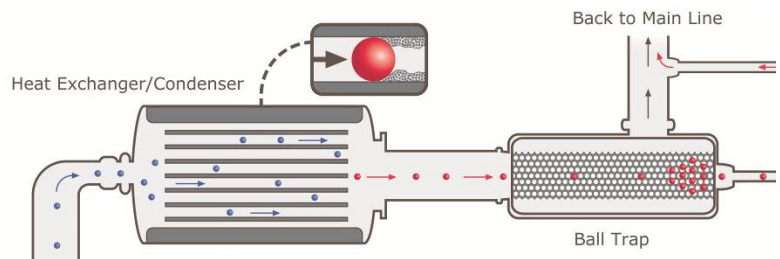
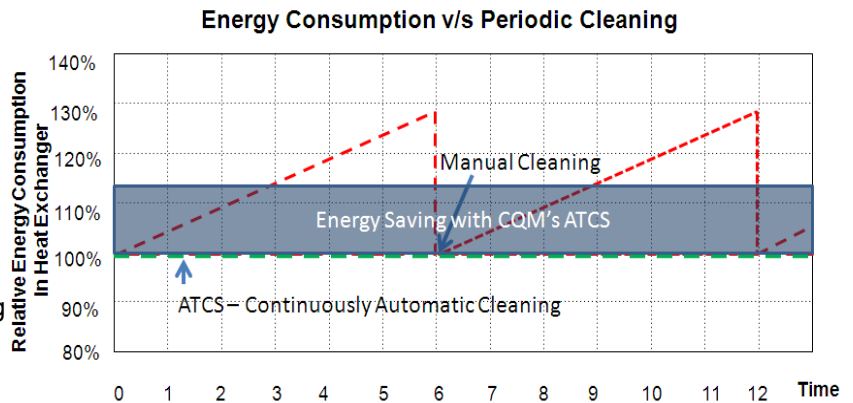

Fouling factor vs. Loss in Efficiency

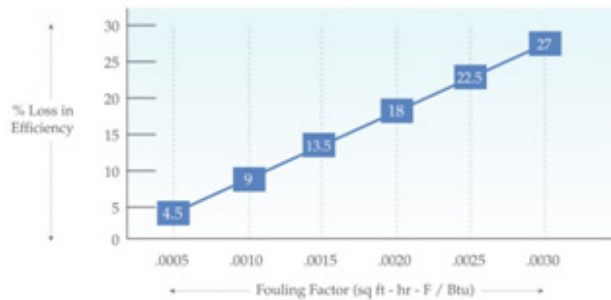

Piper, James E. Operations and Maintenance Manual for Energy Management M.E. Sharpe, Inc. 1999.

[1] Piper, James E. Operations and Maintenance Manual for Energy Management. Sharpe Professional. New York, 1999.

CQM's Solution – Automatic Tube Cleaning Solution

CQM's ATCS provides a comprehensive and cost-effective solution for the most common type of condensers and heat exchangers known as *tube and shell*.

CQM's patented **ATCS**, Automatic Tube Cleaning System, provides the most up-to-date online fouling mitigation solution for:

- ❖ Central Air Conditioning Systems. Up to 25% savings in energy costs, as well as typically 600 Tons of GHG per 1000TR/ year
- ❖ Industrial Cooling and Refrigeration
- ❖ Industrial Processes (e.g. Refineries, Petrochemicals). Significant increase in productivity.
- ❖ Power Plants. Up to 4% increase in annual power generation.

The **ATCS** keeps heat exchangers clean by running sponge balls through the heat exchanger tubes on preset time cycles, eliminating foulant and residue deposits and build-up. It also eliminates expensive downtime by keeping processes running. This environment-friendly system is the key to energy-saving cost effective tube cleaning.

CQM's ATCS includes the following design features:

- ❖ Simplicity of design for greater reliability
- ❖ Easy to operate
- ❖ Hassle-free integration in less than 20 man-hours
- ❖ Simple maintenance
- ❖ Cost effective
- ❖ Environment friendly—no chemicals
- ❖ Heat Exchanger efficiency is not compromised (**ATCS** doesn't re-circulate effluent water)

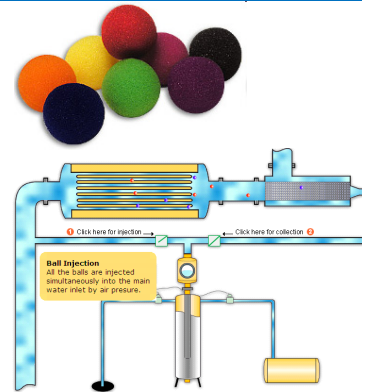

Energy Saved by Using CQM

The "CQM" – Rubber Ball Tube Cleaner is designed to help keep the internal surface of the condenser tubes clean throughout the year. It works continuously, triggered by a Programmable Logic Controller at per-set interval.

Referring to the Condenser Fouling Factor Chart (attached, page 6) taken from the Carrier Handbook.

With the "CQM" – Rubber Ball Tube Cleaner installed, we guarantee that the internal surface the cooling tubes are kept cleaned for better heat transfer and thus saving energy consumption. The area bounded by the horizontal line and the zig-zag line represents the power which can be conserved, i.e. approx. 10%.

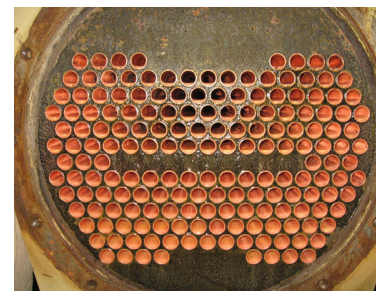

How Does the ATCS Work?

CQM's patented **ATCS** maintains heat exchangers, keeping them clean without time-consuming intervention. Sponge balls slightly larger in diameter than the tubes are injected at set intervals into the system. These rub the tubes clean and are then trapped on the outlet of the heat exchanger where they are collected for the next cleaning cycle. The operation is based on the circulation of the sponge ball through the condenser tube.

The sponge ball must be pushed into the condenser **not more than 15 seconds** by a **high flow of water (min.7L/S)** which can be produced by a high pressure source **at least 2bar** higher than the injection point at the condenser inlet. The source can be either obtained by an air compressor in air injection system or a water injection pump in water injection system.

Both air injection system and water injection system will be operated by a controller which is pre-programmed to execute the cleaning process in two consecutive steps. They are ball injection cycle and ball collection cycle.

The **ATCS** cycle is fully automatic and controlled by a controller as follows:

Air Pressure Driven

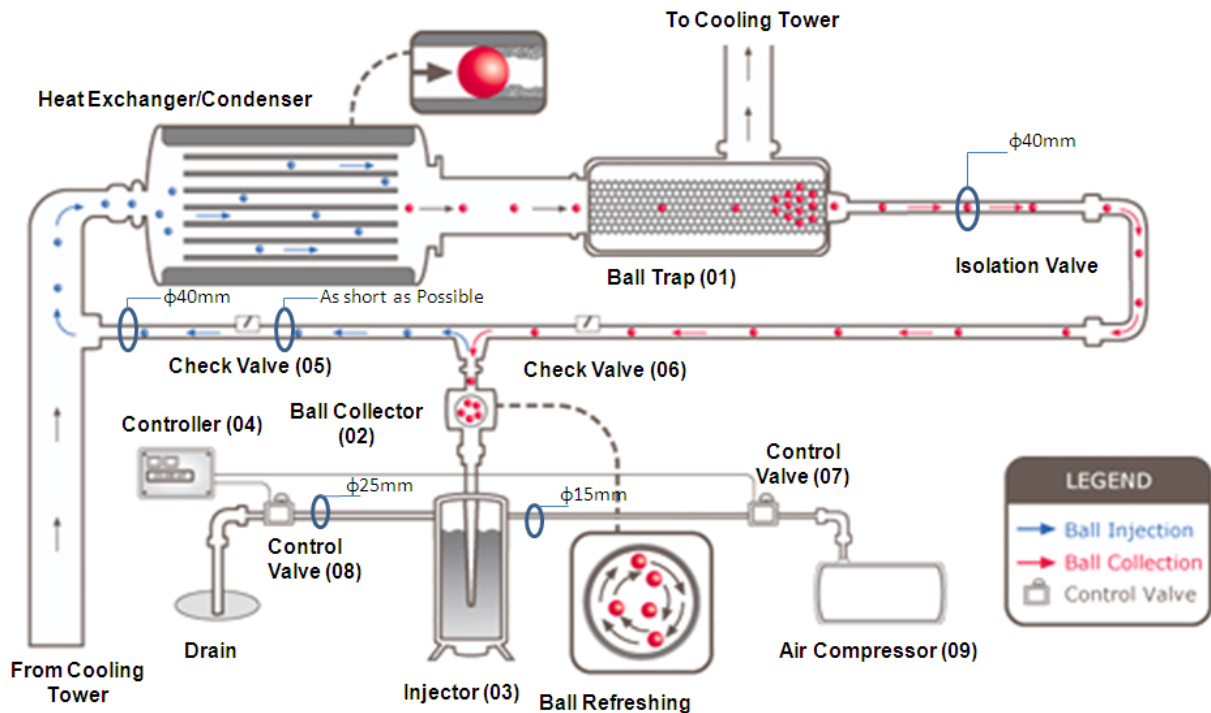

1. The controller (04) shall activate the cleaning process by detecting the on/off status of the corresponding chiller (or condensing water isolating valve). If the chiller is on, the ball will be injected from the collector (02) in the injection cycle and will be collected to the collector (02) in the collection cycle. The check valves (05 & 06) shall be installed in the location as shown on the schematic below and as close as possible to the collector (02) in order to ensure the water flow direction during the injection cycle and the collection cycle. The CONTROLLER (04) shall command the control valves (07 & 08) to open or close so as to manage the injection and the collection.

2. When the system starts the injection cycle, the CONTROLLER (04) shall command the injection control valve (07) to open for couple of seconds (the collection control valve (08) kept closed in the cycle) and then close. The air pressure from the air compressor (09) shall be used to displace the water inside the injector (03) to the collector (02) and force all balls in the collector (02) to the condenser. The cycle shall be completed until the ball passing through the condenser and trapped inside the ball trap unit (01). The time period of the injection cycle is normally pre-set at 3 minutes.

3. After the injection cycle is finished, the CONTROLLER (04) shall command the collection control valve (08) to open for couple of seconds (the injection control valve (07) kept closed in the cycle) and then close. The negative pressure shall let the ball return from the ball trap unit (01) back to the collector (02). At the same time, water shall go into the injector (03) and then to the drain point. The ball shall wait in the collector (02) until the next injection cycle. The time period of the collection cycle is normally pre-set at 27 minutes.

4. The total time of the whole cycle (injection and collection cycle) shall be 30 minutes

Pump Driven

For water cooling applications of high temperature, vacuum or water pressure higher than 8 bar, such as found in steam condensing power plants an electric Pump is used to circulate the balls via the Collector, Heat Exchanger and Trap.

The same is used in non-water cooling applications. The following diagram presents this type of system at both the Ball Injection and Collection stages:

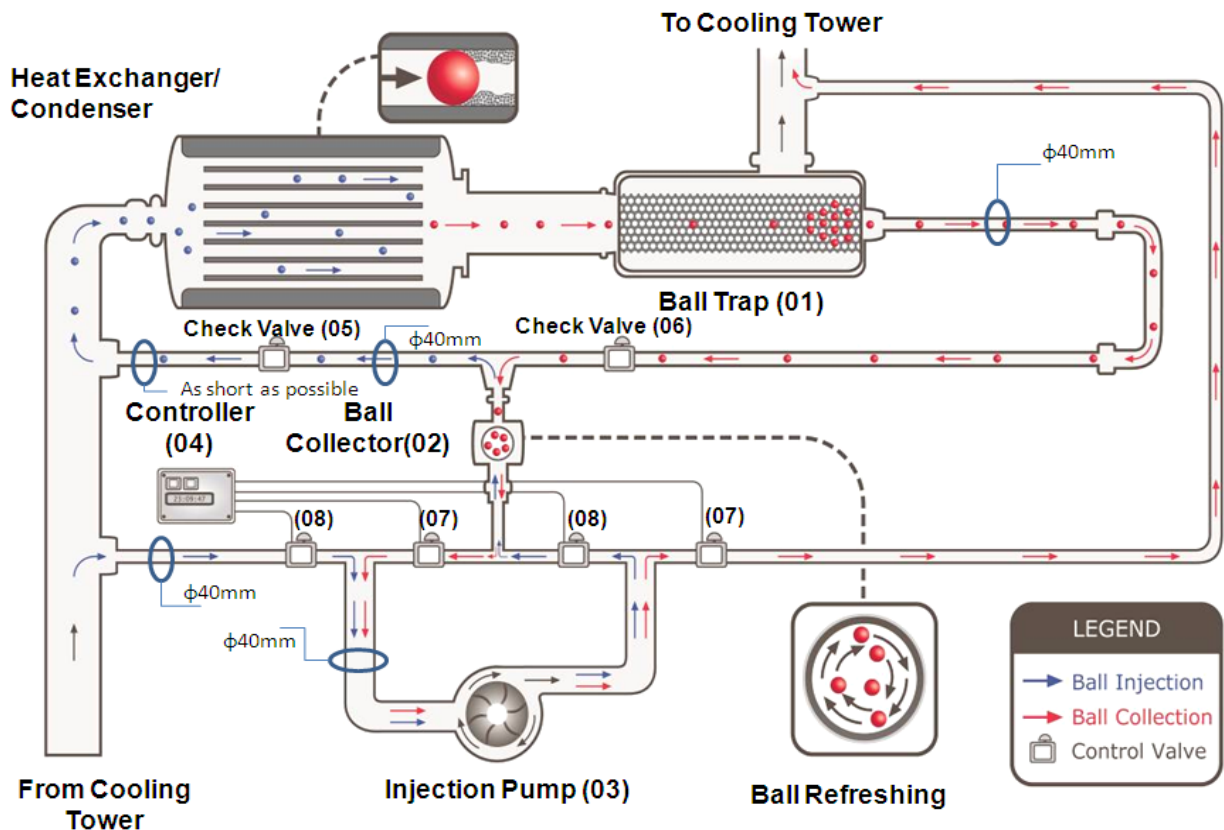

1. Same as air injection system step 1 and repeated as follows. The PLC (04) shall activate the cleaning process by detecting the on/off status of the corresponding chiller (or condensing water isolating valve). If the chiller is on, the ball will be injected from the collector (02) in the injection cycle and will be collected to the collector (02) in the collection cycle. The check valves (05 & 06) shall be installed in the location as shown on the schematic below and as close as possible to the collector (02) in order to ensure the water flow direction during the injection cycle and the collection cycle. The PLC (04) shall command the control valves (07 & 08) to open or close so as to manage the injection and the collection.

2. When the system starts the injection cycle, the PLC (04) shall command the injection control valve (07) to open for couple of seconds (the collection control valve (08) kept closed in the cycle) and then close. The injection pressure from the injection pump (03) shall force all balls in the collector (02) to the condenser. The cycle shall be completed until the ball passing through the condenser and trapped inside the ball trap unit (01). The time period of the injection cycle is normally pre-set at 3 minutes.

3. After the injection cycle is finished, the PLC (04) shall command the control valve (08) to open for couple of seconds (the injection control valve (07) kept closed in the cycle) and then close.

The suction pressure from the injection pump (03) shall let the ball return from the ball trap unit (01) back to the collector (02). At the same time, water shall go through the injection pump (03) and then back to the condensing water pipe. The ball shall wait in the collector (02) until the next injection cycle. The time period of the collection cycle is normally pre-set at 27 minutes.

4. Same as air injection system step 4 and repeated as follows. The total time of the whole cycle (injection and collection cycle) shall be 30 minutes.

Applications and Industries

Facilities

Improve Energy Efficiency; Reduce Maintenance Expense

Now large facilities like hospitals and universities can increase the energy efficiency of central air conditioning systems and cooling towers with CQM.

Our innovative technology combines our [automatic tube cleaning system](#) (ATCS) with our [scale removal system](#) (SRS). This keeps chiller tubes continuously clean, while eliminating the need for water treatment chemical use.

Your organization will see optimized cooling efficiency, reduced energy and water consumption, reduced environmental pollution discharges and improved plant health and safety.

Benefits

Improved Efficiency: Reduce comfort cooling energy costs by up to 25%. Eliminate scaling and biofilm condenser fouling to continuously operate chiller condenser at maximum efficiency. Reduce cooling tower bleed water by up to 80%.

Rapid Return on Investment:

Typical simple payback period of less than 2 years on equipment. Equipment life of 15-20 years often yields internal rates of return (IRR) in excess of 50%.



Sustainability: Reduce energy consumption, water usage and greenhouse gas emissions.

Eliminate cooling tower water treatment chemicals. Eliminate cooling tower water treatment chemicals, which means no hazardous chemicals to contain or dispose.

Reduced Maintenance Expense:

Drastically reduce or eliminate costly and time-consuming offline condenser cleaning costs. Eliminate expensive cooling water treatment chemicals.



A Improved Way to Increase Your Power Generation Capacity

CQM provides innovative solutions for online cleaning of steam condensers, and shell and tube heat exchangers in either steam or combined cycle plants. You'll not only get continuously clean, efficient heat exchangers — you'll see increased power generation capacity. Better yet, your organization will also save on energy and maintenance costs.

Benefits

- Increased Power Generation:** Increase power output by 0.5%-4%. Power is generated at maximum efficiency at all times. Extend plant availability, as there is no need to shut down your condenser for cleaning.
- Improved Reliability:** Less moving parts = higher reliability. No moving parts in the CQM ball trap means absolutely no sponge balls are lost. It provides simple maintenance through continuous, online cleaning. Sponge balls do not travel through a pump and therefore do not wear out. Accurate control of the cleaning process means cleaning periods are customizable to maintain a high level of performance and minimize sponge balls wear.
- Rapid Return on Investment:** The typical simple payback period is less than 2 years on equipment. Equipment life of 15-20 years often yields internal rates of return (IRR) in excess of 50%.
- Reduced Maintenance Expense:** Drastically reduce or eliminate costly and time-consuming offline condenser cleaning costs. Eliminate expensive cooling water treatment chemicals.
- Sustainability:** Reduce energy consumption, water usage and greenhouse gas emissions. Eliminate cooling tower water treatment chemicals. Eliminate chemical cleaning of condensers so there are no hazardous chemicals to contain or dispose.



Applications and Industries

Industrial and Manufacturing

An Innovative Way to Save On Process Cooling and Comfort Cooling

Now there's a simple solution for improving the efficiency of your plant's cooling process.

CQM offers an innovative [automatic tube cleaning system \(ATCS\)](#) technology that cleans your plant's heat exchangers naturally and sustainably — without costly process shutdowns or chemical treatments. You can also use the ATCS solution to increase your plant's comfort cooling efficiency.

When you combine the efficiency of the ATCS with our [scale removal system](#), your whole operation will enjoy leading-edge cooling efficiency. The SRS is a chemical-free, environmentally-friendly water treatment solution for removing scale and keeping cooling water circuits clean. In hundreds of installations throughout the world, CQM SRS technology prevents scale and sludge buildup in cooling towers, and open and closed loop cooling systems — eliminating the need for chemical water treatment and manual cleaning.

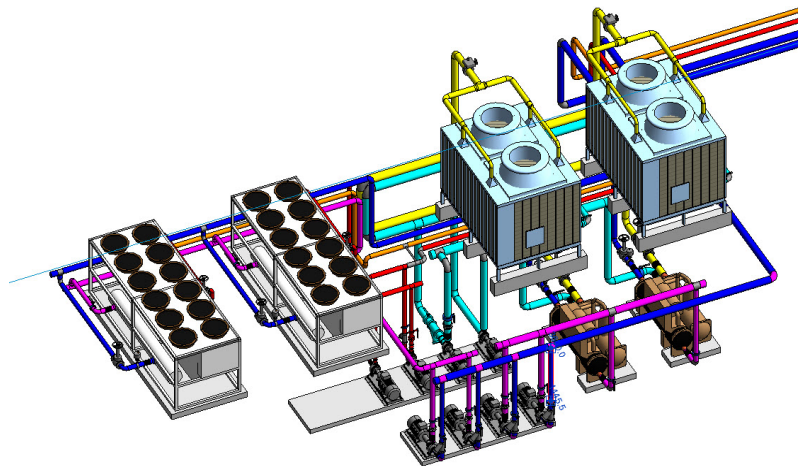

Benefits

- Increased Productivity:** Eliminate the need for process shutdown to clean heat exchanger tubes. Reduce process upsets by continuously operating heat exchangers at stable maximum efficiency.
- Improved Efficiency:** Reduce comfort cooling energy costs by up to 25%. Eliminate scaling and biofilm condenser fouling to continuously operate a chiller condenser at maximum efficiency. Reduce cooling tower bleed water by up to 80%.
- Reduced Maintenance Expense:** Drastically reduce or eliminate costly and time-consuming downtime for heat exchanger cleaning. Eliminate expensive cooling water treatment chemicals.

Sustainability: Reduce energy consumption, water usage and greenhouse gas emissions. Reduce cooling tower bleed water by up to 80%. Eliminate cooling tower water treatment chemicals. No hazardous chemicals to contain and dispose of due to heat exchanger cleanings.

With over 2,300 installations worldwide, our patented ATCS technology has proven effective in a wide range of applications: water, fuels, lubricants, acids and other fouling liquids. And we provide fouling-prevention solutions for heat exchangers working in extreme temperatures, with corrosive liquids or other extreme fouling conditions.



Get Clean Tubes Safely and Efficiently — Without Shutdowns

Now there's a simple solution for improving the efficiency of your refinery's cooling process. CQM offers an innovative [automatic tube cleaning system](#) (ATCS) technology that cleans your refinery's heat exchangers naturally and sustainably — without costly process shutdowns or chemical treatments.

And when your tubes are clean, the productivity of your refinery improves.

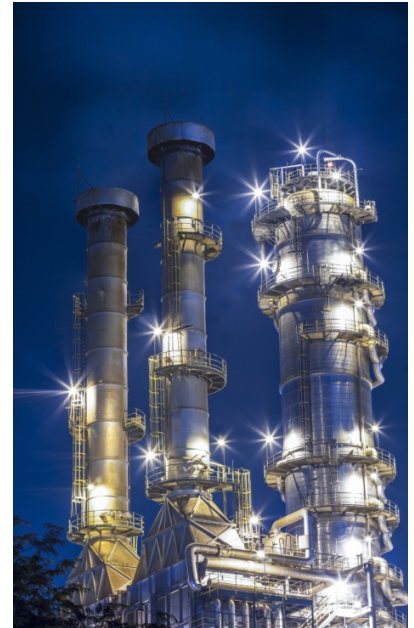

Benefits

- Increased Productivity:** Eliminate the need for process shutdown to clean heat exchanger tubes. Reduce process upsets by continuously operating heat exchangers at stable maximum efficiency.
- Reduced Maintenance Expense:** Drastically reduce or eliminate costly and time-consuming downtime for heat exchanger cleaning. Eliminate expensive cooling water treatment chemicals.
- Sustainability:** Reduce energy consumption, water usage and greenhouse gas emissions. Reduce cooling tower bleed water by up to 80%. Eliminate cooling tower water treatment chemicals. No hazardous chemicals to contain and dispose of due to heat exchanger cleanings.

Sizing and Selection of CQM

1. Select the model number (refer to the page ...for the model table)

The inlet and outlet connection of the ball trap unit must be same as the condensing water pipe size of each chiller. For example, the model CQ-8 shall be selected for condensing water pipe size of diameter 8 inch.

2. Select the injection method

(working principle for air injection system on page 4 or water injection system on page 5)

- If water drainage is allowed, you will choose between air injection system and water injection system
Inlet pressure at condensing water pipe < 6bar, use AIR INJECTION SYSTEM
Inlet pressure at condensing water pipe > 6bar, use WATER INJECTION SYSTEM
- If water drainage is NOT allowed, only WATER INJECTION SYSTEM.

3. Select the material (fresh water application or sea water application)

Detail of material can be referred to the system components shown on page 8 to 11. Ball trap unit, ball collector and ball injector shall be made from carbon steel coated with epoxy in both applications
Zinc anode shall be installed in each of them in order to give further protection in sea water application. Other components in the system shall be generally made from brass or cast iron material in fresh water application and SS316 or equivalent material in sea water application.

- Use **FRESH WATER APPLICATION** for fresh water cooling tower.
- Use **SEA WATER APPLICATION** for direct sea water cooling or sea water cooling tower

4. Select the type of ball trap unit

to fit your piping arrangement
CQM offers three types of ball trap unit to suit the piping arrangement at the condensing water outlet of each chiller (dimension table is shown on page 10).

- In-line type most common use
- Angular type replace the elbow
- T-shape type shortest condensing water length

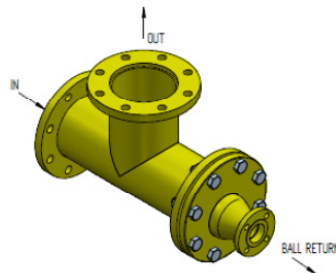
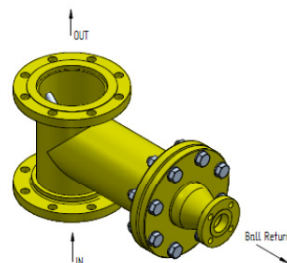
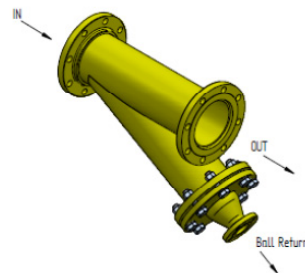

CQM system is mostly recommended for installation on a one-to-one operation. However, one-to-two operation could be possible and please contact our distributors for more information.

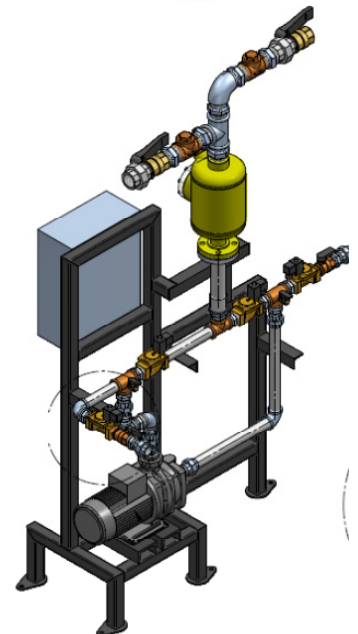

System Components

Controller

It is operating on 220Vac/50Hz and outputs 24Vdc or dry contact to all control valves. It can be easily programmed locally with an auto power-off LCD display and keypad.

The CONTROLLER is designed to operate six (6) numbers of **CQM** systems for both air injection system and water injection system.



Ball Collector

The collector shall be made from a carbon steel material, coated with high performance baked-on epoxy for corrosion protection. It shall have a built-in transparent window for visual inspection of the balls. The distance between the collector and the condenser inlet shall not exceed 4m and as short as possible. The collector shall be located between the injector and the condenser, in a position, to allow easy access to the observation window.

Zinc anode shall be added to give further protection on sea water application. Ball replacement can be done by loosen the screw on the transparent window.

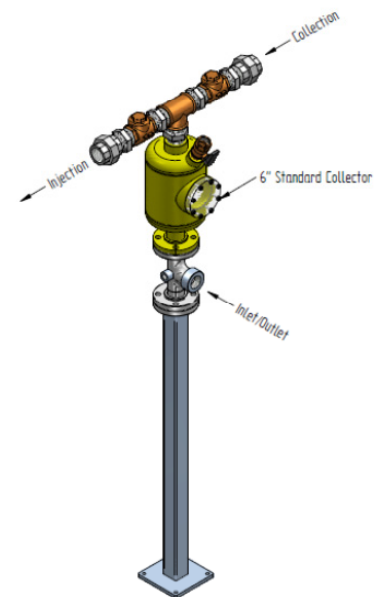

BALL INJECTOR (For Air Injection System)

For air injection system, compressed air shall be used to displace the water inside the injector into the collector at **WATER FLOW RATE AT LEAST 7L/S** by the pushing **PRESSURE AT LEAST 2BAR** higher than that at injection point on the condenser inlet pipe. The injector shall be made from a carbon steel material, coated with high performance baked-on epoxy for corrosion protection (When the condensing water pipe of the condenser is 20" - 28", its diameter is 8" - 14" in accordance).

Zinc anode shall be added to give further protection on sea water application.

The air compressor shall be sized to give minimum 10bar air pressure and the capacity of air tank shall be at least 25L.

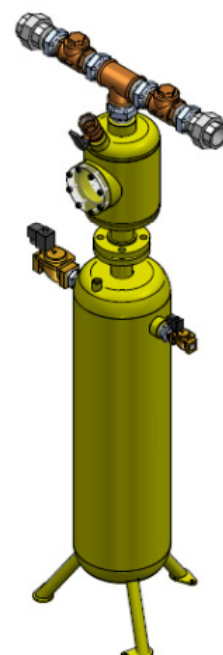

System Components

INJECTION PUMP (For Water Injection System)

For water injection system, injection pump shall be used to push the sponge ball inside the collector.

The pump shall be sized to deliver **AT LEAST 2BAR PUMP HEAD AND 7L/S WATER FLOW RATE**. The sponge ball is not allowed to pass through the injection pump. The casing shall be made from cast iron with brass impeller in fresh water application while the casing and impeller shall be made from SS316 in sea water application

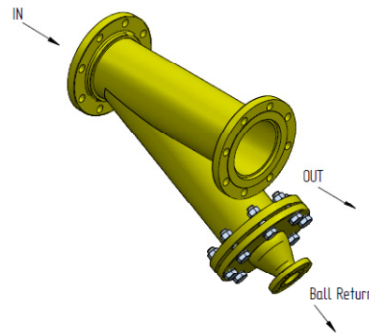
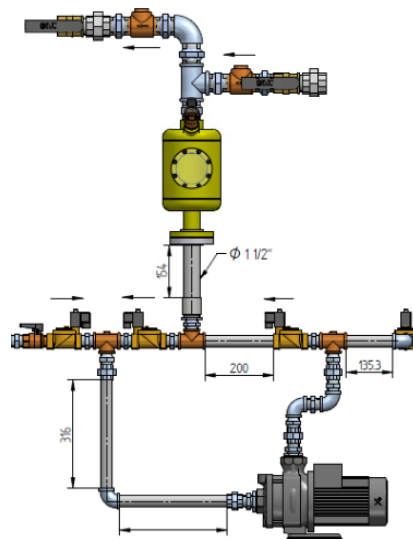

Water Injection System

Motorized 2-way water valve for both injection and collection valve shall be selected with brass body for fresh water application and SS316 for sea water application.

SPONGE BALL

The sponge ball shall be manufactured in different types, sizes, hardness and temperature resistance for different application. In general, the size of the sponge ball used shall be 1mm in diameter larger than the inner diameter of the cooling tubes of the condenser. The number of balls required in the system shall not exceed 50% of the quantity of tubes per pass.



BALL TRAP

The ball trap shall be mounted between two flanges at the outlet line of the condenser. The casing shall be made from a carbon steel material, coated with high performance baked-on epoxy for corrosion protection.

The screen inside is made from stainless steel SS316L perforated metal sheet.

The screen area is designed **AT LEAST FIVE TIMES** larger than the surface area of the inlet line section so that the flow-rate is uninterrupted. The pressure loss across the ball trap shall not be larger than 5kPa and shall never allow balls to escape from the system. The distance from the end of the ball trap to the wall shall be **AT LEAST 1.5 x B** (length of the screen) in order to allow enough space to take out the screen for maintenance.

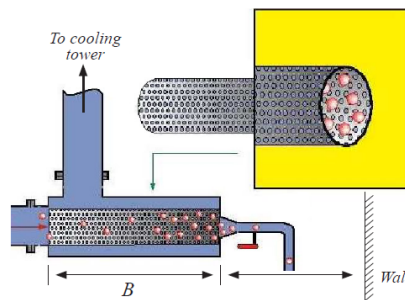

PIPING - BALL TRANSPORTATION LINE

Fresh Water Application

The ball transportation pipe shall be made of galvanized iron, carbon steel or material compatible with the condensing water pipe while air pipe shall be made of copper. All pipes shall be able to sustain the system working pressure. Please refer to page 9 & 10 for the pipe size on the schematic.

Sea Water Application

The ball transportation pipe shall be made of SS316, PVC or material compatible with the condensing water pipe. All pipes shall be able to sustain the system working pressure. Please refer to page 9 & 10 for the pipe size on the schematic.

CONTROL VALVES (INJECTION & COLLECTION VALVES)

Air Injection System

Solenoid 2-way air valve for injection valve and pneumatic 2-way water valve for collection valve shall be selected with brass body for fresh water application and SS316 for sea water application.

Model Table with Dimension

In-Line Type

Mounted in-line with the condensing water pipe

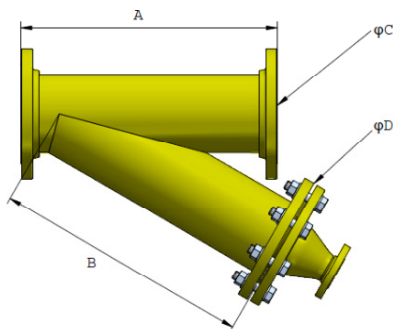

Angular Type

Mounted in-line with the outlet 90° from the condensing water pipe

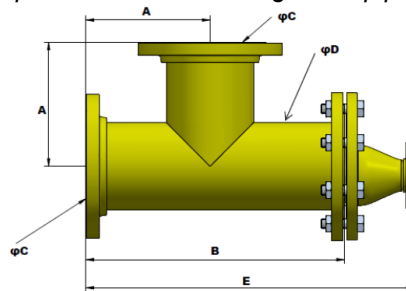

T-Shape Type

Mounted in-line with the condensing water pipe

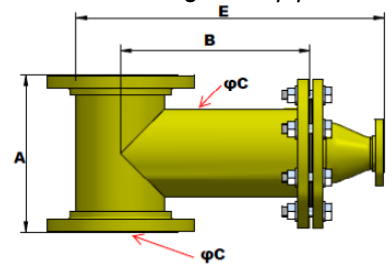

Model	Dimension in mm									
	In-Line		Angular			T-Shape			Common	
	A	B	A	B	E	A	B	E	C	D
CQM-03	450	350	127	350	585	200	150	225	3"	6"
CQM-04	550	300	165	300	740	250	200	300	4"	8"
CQM-05	600	600	203	600	1000	300	300	450	5"	10"
CQM-06	700	700	242	700	1017	300	300	450	6"	10"
CQM-08	800	900	318	900	1205	340	400	600	8"	12"
CQM-10	1000	1000	394	1000	1470	400	500	750	10"	16"
CQM-12	1200	1100	470	1100	1610	450	600	900	12"	18"
CQM-14	1350	1200	546	1200	1645	550	700	1050	14"	20"
CQM-16	1500	1300	623	1300	1850	650	800	1200	16"	22"
CQM-18	1800	1400	699	1400	2100	700	900	1350	18"	24"
CQM-20	2000	1500	775	1500	2220	800	1000	1500	20"	26"
CQM-22	2100	1600	851	1600	2250	900	1100	1650	22"	28"
CQM-24	2200	1700	927	1700	2300	1000	1200	1800	24"	30"
CQM-26	2400	1800	1004	1800	2350	1050	1300	1950	26"	32"
CQM-28	2600	1900	1079	1900	2400	1150	1400	2100	28"	34"

The above calculation and measurement are only a guide. It may be changed without notice as the Manufacturer deemed necessary. Please contact our local representative for other sizes

